

SCHEMATIC REV A	PCBA NUMBER X8XXXXX-001	REV A	BOM RELEASE DATE XX/XX/06
--------------------	----------------------------	----------	------------------------------

PAGE	CONTENTS
[1]	COVER PAGE
[2]	CLOCK DIAGRAM
[3]	RESET/ENABLE DIAGRAM
[4]	CPU, CLOCKS + EEPROM + STRAPPING
[5]	CPU, FSB
[6]	CPU, FSB POWER + PLL POWER
[7]	CPU, CORE POWER
[8]	CPU, POWER
[9]	CPU, DECOUPLING
[10]	CPU, DECOUPLING
[11]	CPU, DECOUPLING
[12]	GPU, FSB
[13]	GPU, VIDEO + PCIEX + EEPROM
[14]	GPU, MEMORY CONTROLLER A + B
[15]	GPU, MEMORY CONTROLLER C + D
[16]	GPU, PLL POWER + FSB POWER
[17]	GPU, CORE POWER + MEM POWER
[18]	GPU, DECOUPLING
[19]	MEMORY, A (TOP)
[20]	MEMORY, A MIRRORED (BOTTOM)
[21]	MEMORY, B (TOP)
[22]	MEMORY, B MIRRORED (BOTTOM)
[23]	MEMORY, C (TOP)
[24]	MEMORY, C MIRRORED (BOTTOM)
[25]	MEMORY, D (TOP)
[26]	MEMORY, D MIRRORED (BOTTOM)
[27]	HANA, CLOCKS + STRAPPING
[28]	HANA, VIDEO + FAN + JTAG
[29]	CONN, HDMI
[30]	HANA, POWER + DECOUPLING
[31]	HANA, POWER + DECOUPLING
[32]	POWER TRACE EMI CAPS
[33]	SB, PCIEX + SMM GPIO + JTAG
[34]	SB, SMC

PAGE	CONTENTS
[35]	SB, FLASH + USB + SPI
[36]	SB, ETHERNET + AUDIO + SATA
[37]	SB, STANDBY POWER + DECOUPLE
[38]	SB, MAIN POWER + DECOUPLE
[39]	SB OUT, ETHERNET (ICS PHY)
[40]	SB OUT, ETHERNET (BCM PHY)
[41]	SB OUT, AUDIO
[42]	SB OUT, FLASH
[43]	SB OUT, FAN + IR + BUTTON + TILT
[44]	CONN, AVIP
[45]	CONN, RJ45 + USB COMBO
[46]	CONN, GAME PORTS + MEMORY PORTS
[47]	MISC, V 5P0 DUAL, DEBUG MAPPING
[48]	CONN, ODD AND HDD
[49]	CONN, ARGON + POWER
[50]	VREGS, INPUT + OUTPUT FILTERS
[51]	VREGS, CPU CONTROLLER
[52]	VREGS, GPU OUTPUT PHASE 1,2,3
[53]	VREGS, GPU CONTROLLER
[54]	VREGS, GPU OUTPUT PHASE 1,2
[55]	VREGS, SWITCHED 1.8, 5.0V
[56]	VREGS, LINEAR REGULATORS
[57]	VREGS, VCS REGULATORS
[58]	XDK, DEBUG CONN
[59]	DEBUG BOARD, CPU + GPU BREAKOUT
[60]	DEBUG BOARD, CPU CONN
[61]	DEBUG BOARD, CPU CONN + TERM
[62]	DEBUG BOARD, CPU TERM
[63]	DEBUG BOARD, SMP CONNECTORS
[64]	DEBUG BOARD, GPU CONN + TERM
[65]	XDK, LEDS, DEBUG TITAN
[66]	LABELS AND MOUNTING
[67]	GPU VID BOARD + IMPEDANCE CUPONS
[68]	VREGS, SWITCHED 1P8STBY, 3P3STBY

TONASKET
RETAIL
REV A
FAB A

RULES: (APPLIED WHEN POSSIBLE)

- 1.) MSB TO LSB IS TOP TO BOTTOM
- 2.) WHEN POSSIBLE, INPUTS ON LEFT, OUTPUTS ON RIGHT
- 3.) ORDER OF PAGES CHIP INTERFACES, TERMINATION, POWER, DECOUPLING
- 4.) AVOID USING OFF PAGE CONNECTORS FOR ON PAGE CONNECTIONS
- 5.) LANED SIGNALS ARE GROUPED ON SYMBOLS
- 6.) TRANSMITTER NAME USED AS PREFIX WITH RX AND TX CONNECTIONS
- 7.) SUFFIX V IS USED FOR VOLTAGE RAIL SIGNAL NAMES
- 8.) SUFFIX DP AND DN ARE USED FOR DIFFERENTIAL PAIRS
- 9.) UNNAMED NETS ARE NAMED WITH /2, TEXT SIZE
- 10.) SUFFIX N FOR ACTIVE, LOW OR N JUNCTION
- 11.) SUFFIX TP FOR P JUNCTION
- 12.) SUFFIX EN FOR ENABLE
- 13.) CLK FOR CLOCKS, RST FOR RESETS
- 14.) PWRGD FOR POWER GOOD

[PAGE_TITLE=COVER PAGE]

DRAWING
 TONASKET_FAB_A
 Thu Jan 29 11:33:07 2009

TONASKET
 PLEASE REFER TO THE XENON DESIGN SPEC

BOM RELEASE DATE	XXXX06	PB NUMBER	X80XXXX-00X
SIGNATURE	DATE	MICROSOFT XBOX	
DRN BY		TITLE	
CHK BY		SCH, PBA, TONASKET	
ENGR			
APVD		MICROSOFT	PROJECT NAME
APVD		CONFIDENTIAL	H09517
		PAGE	REV
		1/83	A

* THIS IS OUT OF DATE *
CLOCK DIAGRAM

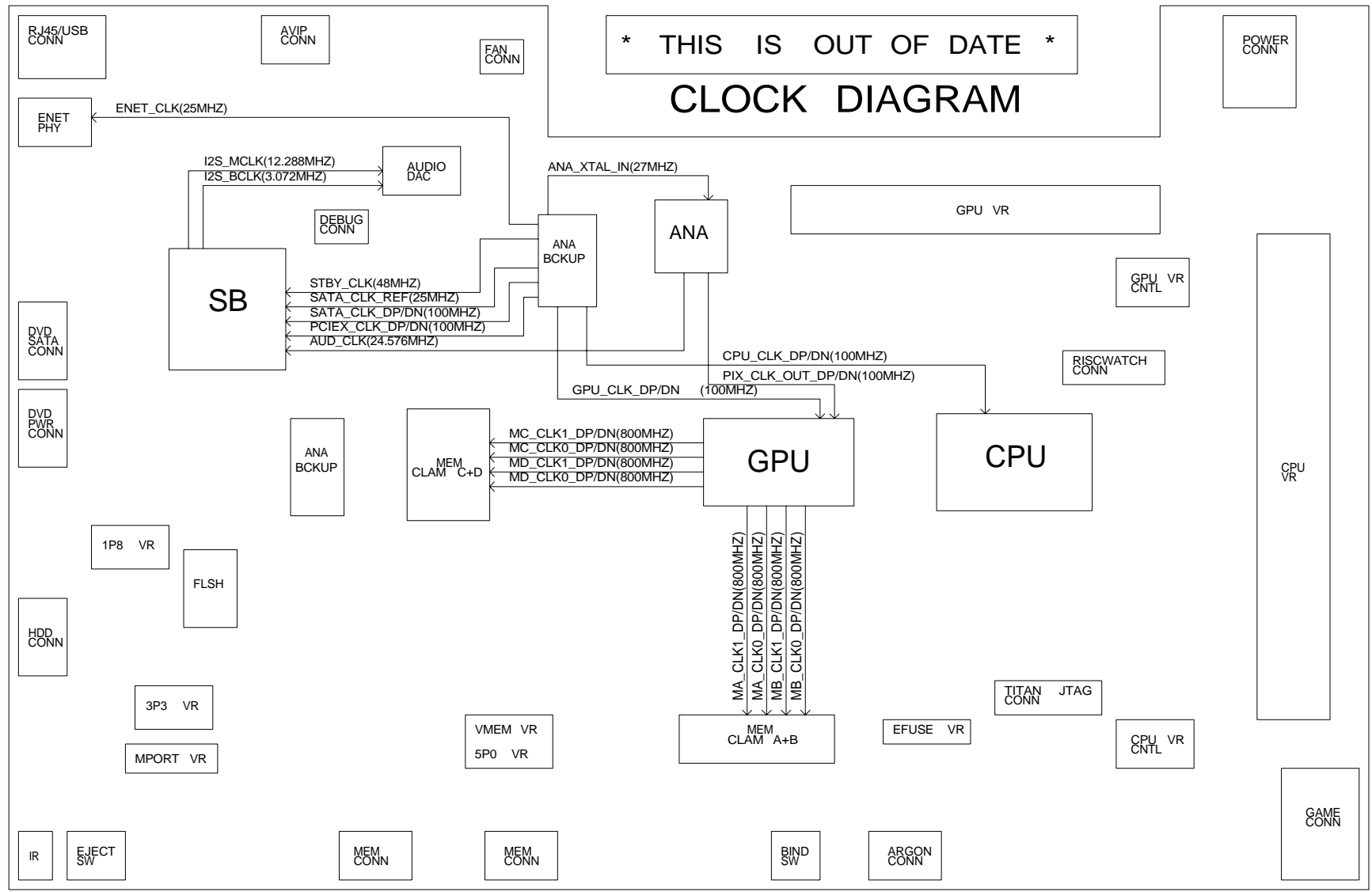

RESET/ENABLE DIAGRAM

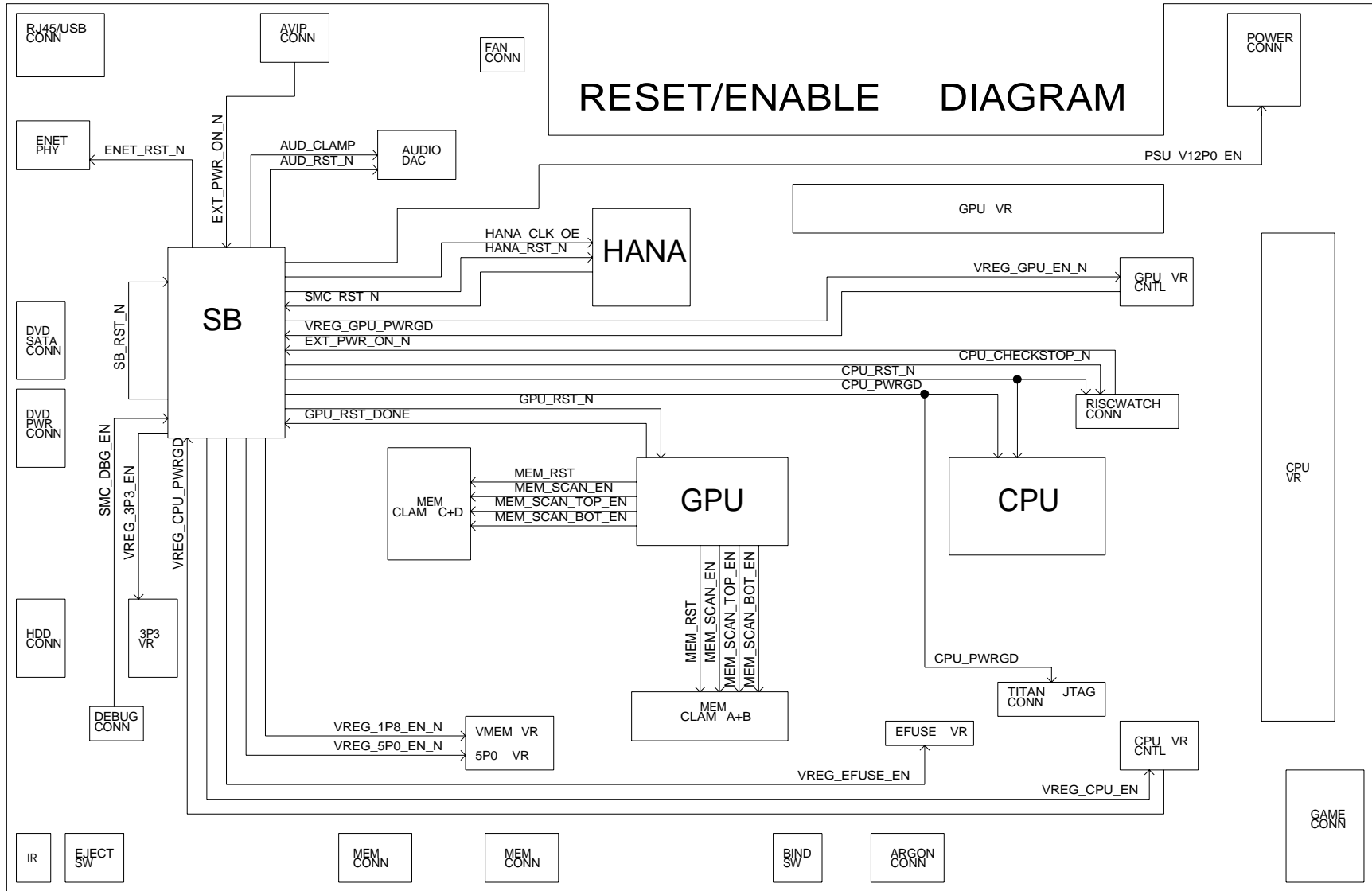

[PAGE_TITLE=RESET/ENABLE DIAGRAM]

DRAWING
TONASKET_FAB_A
Thu Jan 29 11:33:09 2009

CPU, CLOCKS + EEPROM + STRAPPING

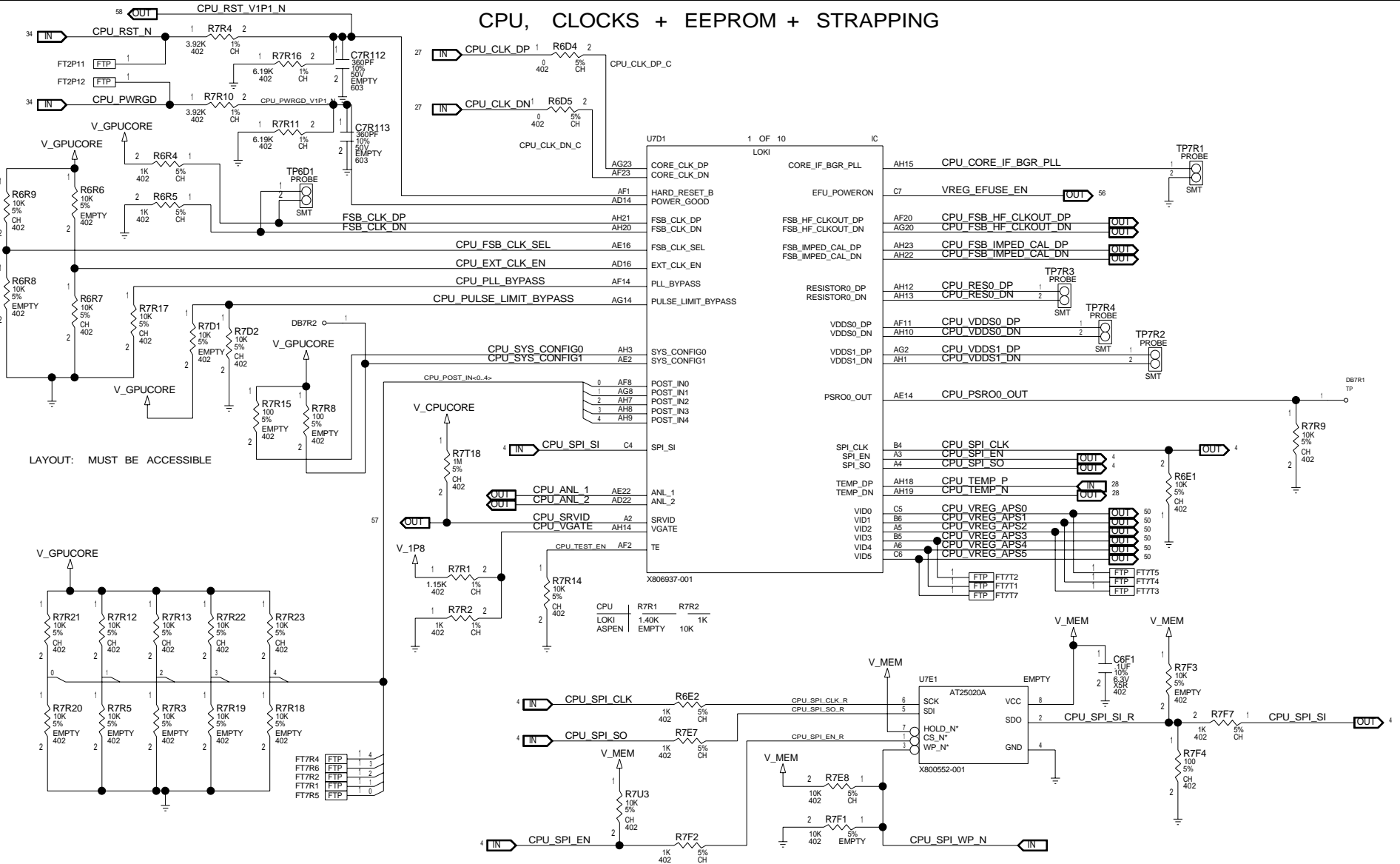

LAYOUT: MUST BE ACCESSIBLE

[PAGE_TITLE=CPU, CLOCKS + EEPROM + STRAPPING]

DRAWING TONASKET_FAB_A Thu Jan 29 11:46:05 2009

MICROSOFT CONFIDENTIAL	PROJECT NAME H09517	PAGE 4/83	REV A
------------------------	---------------------	-----------	-------

CPU, FSB

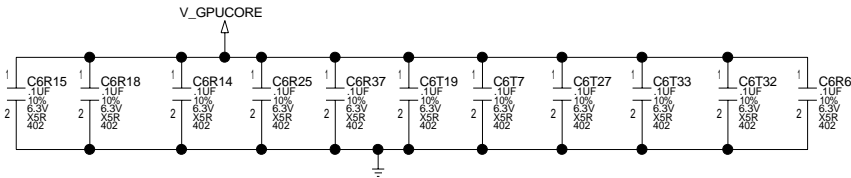
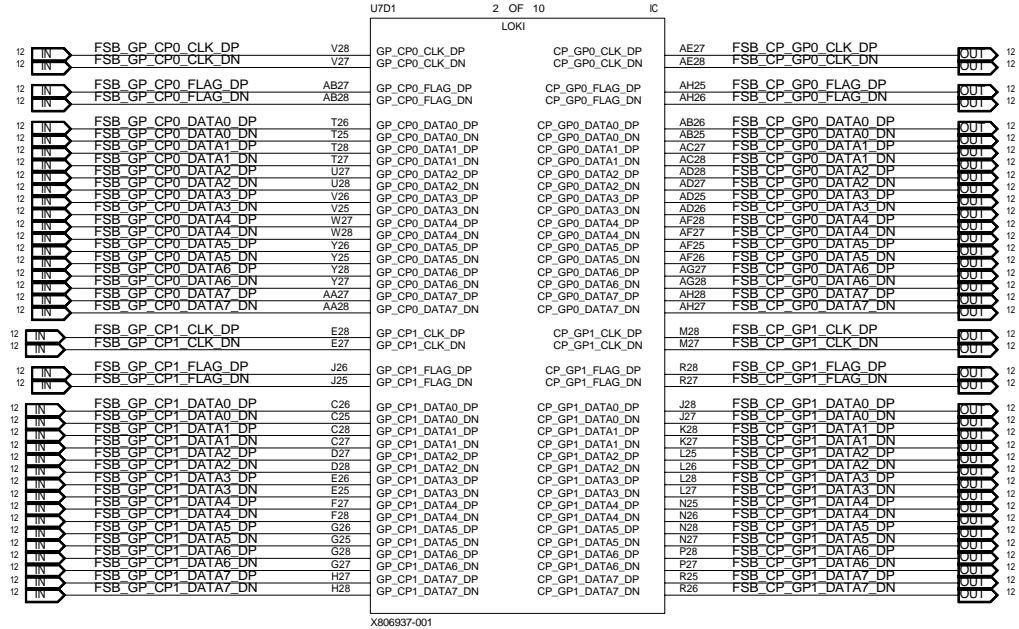

CPU, FSB POWER + PLL POWER

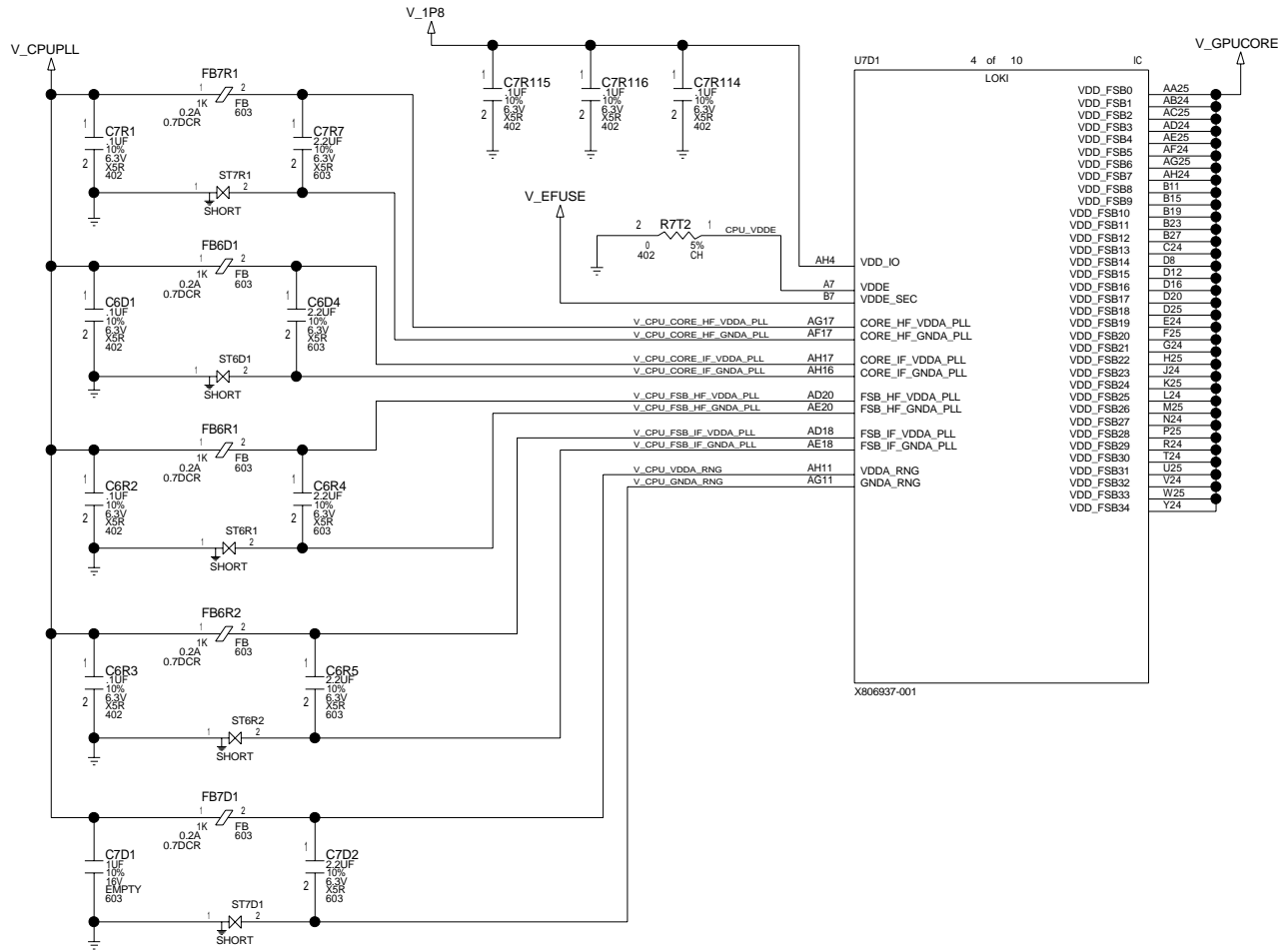

CPU, CORE POWER

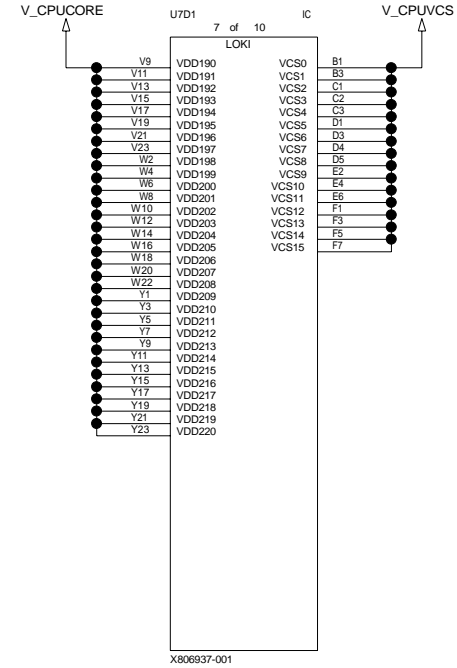
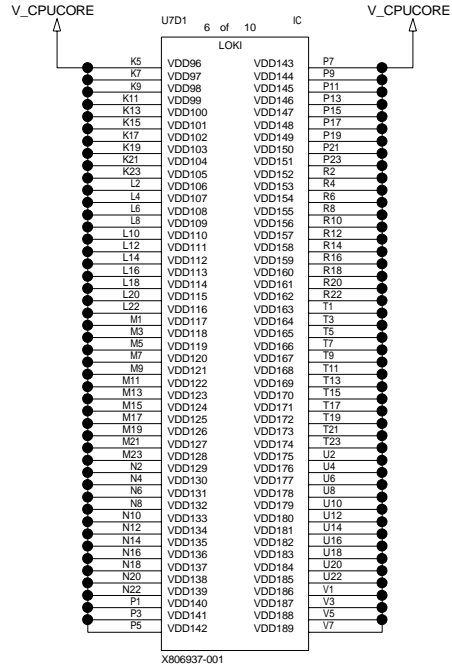
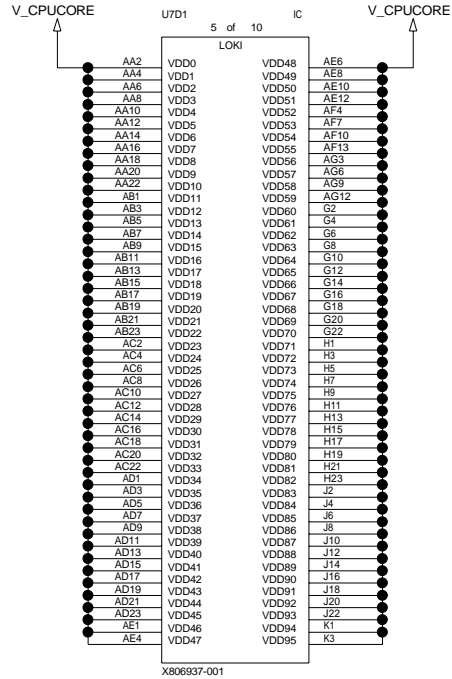

CPU, POWER

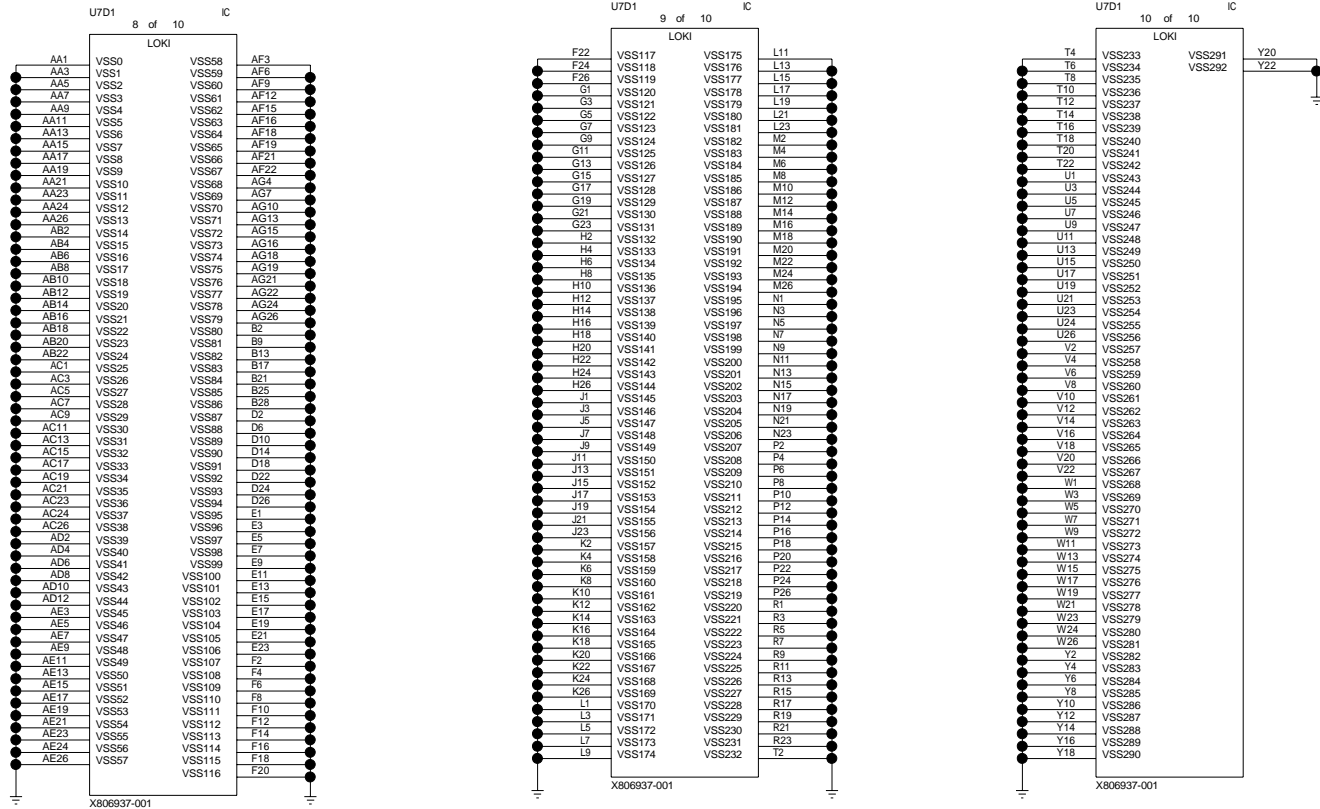

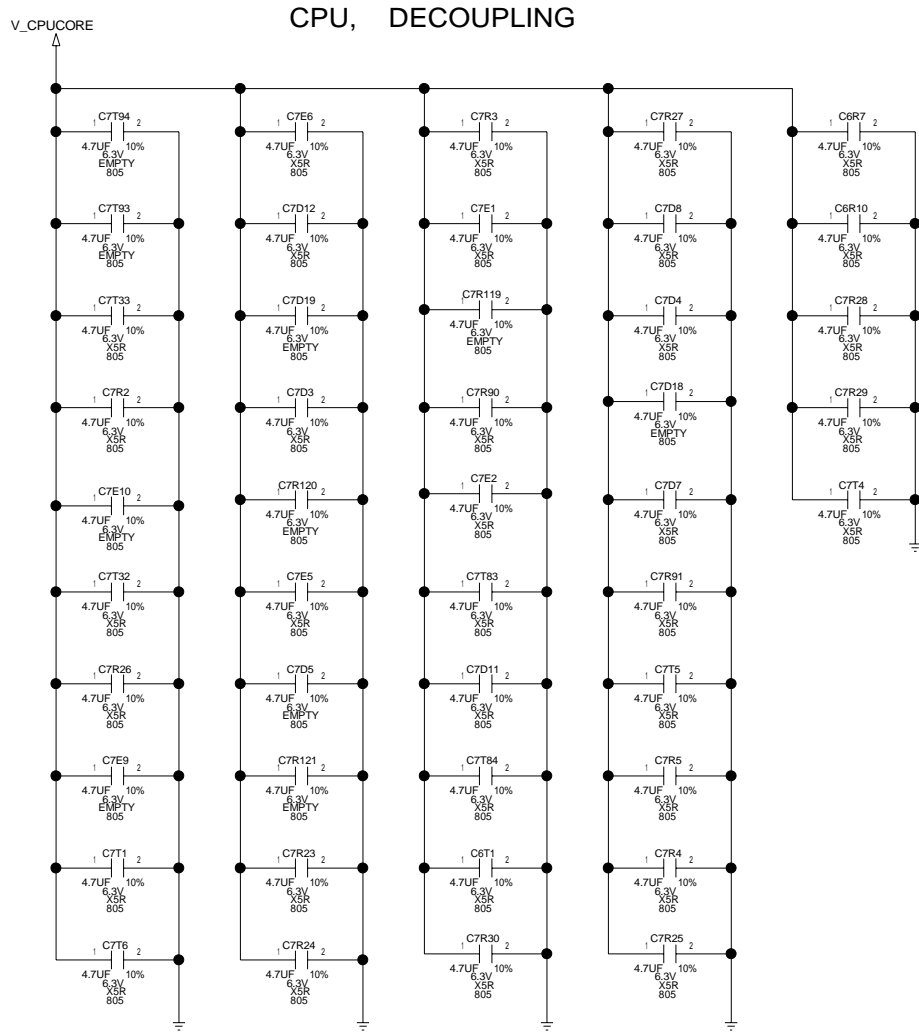

[PAGE_TITLE=CPU, DECOUPLING]

DRAWING
TONASKET_FAB_A
Thu Jan 29 11:46:18

2009

MICROSOFT CONFIDENTIAL	PROJECT NAME H09517	PAGE 9/83	REV A
---------------------------	------------------------	--------------	----------

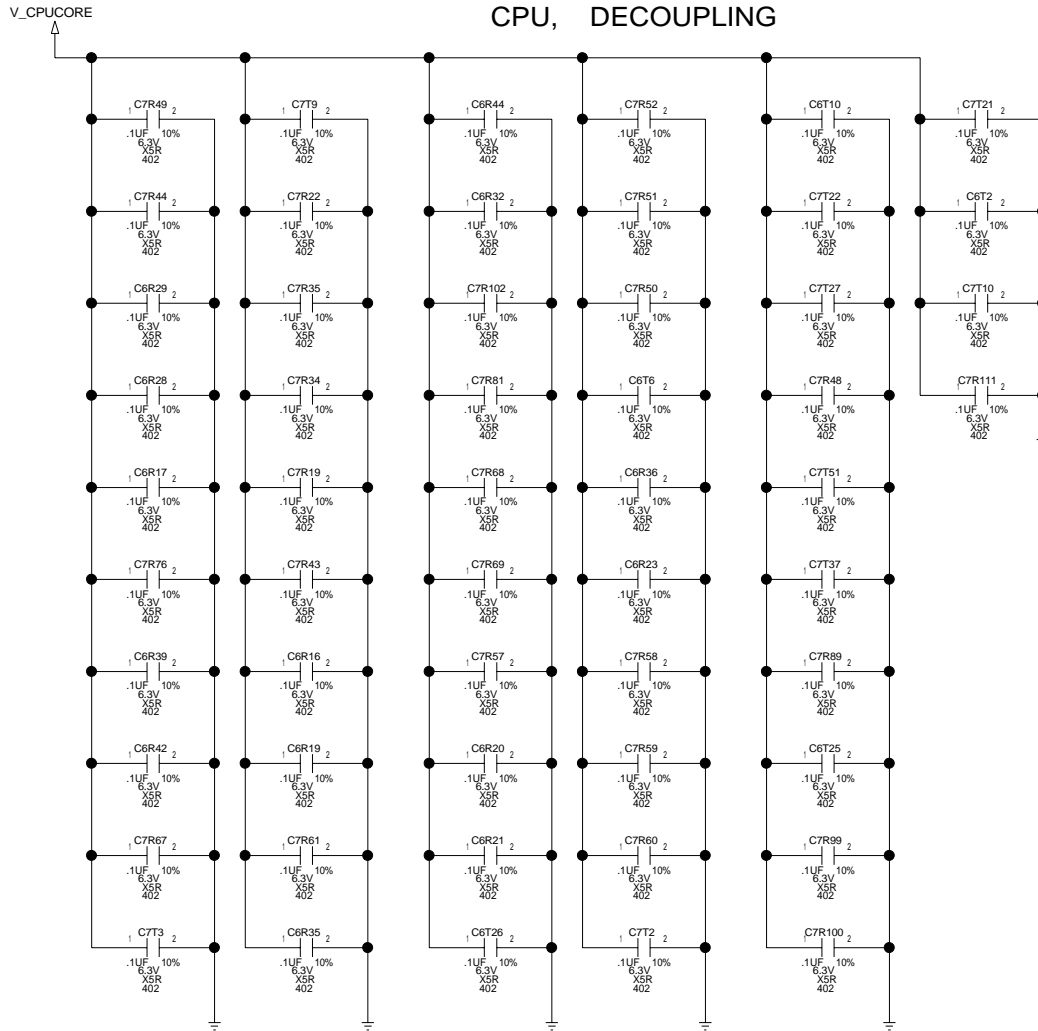

[PAGE_TITLE=CPU, DECOUPLING]

DRAWING
TONASKET_FAB_A
Thu Jan 29 11:46:19 2009

MICROSOFT CONFIDENTIAL	PROJECT NAME H09517	PAGE 10/83	REV A
---------------------------	------------------------	---------------	----------

CPU, DECOUPLING

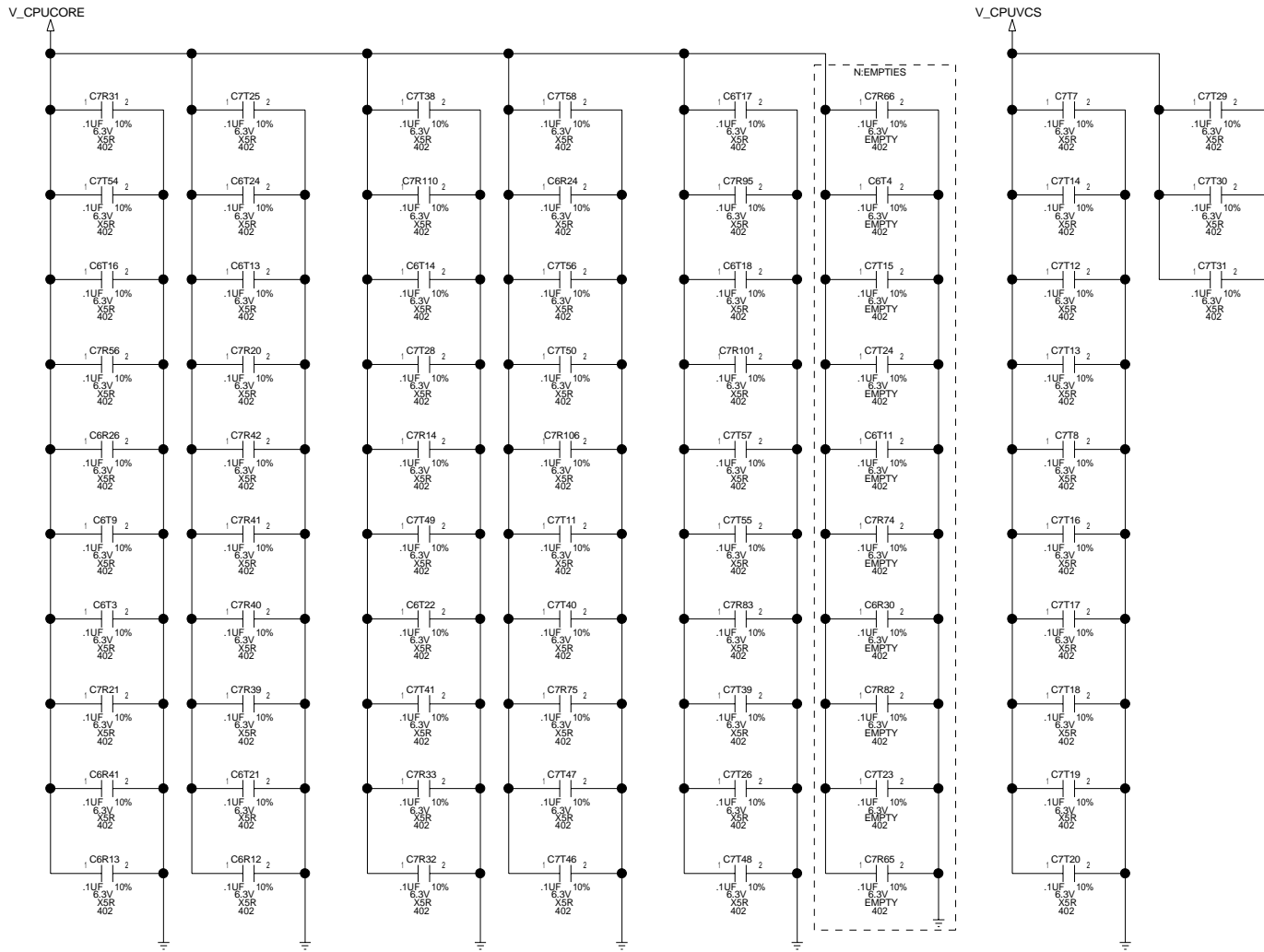

GPU, FSB

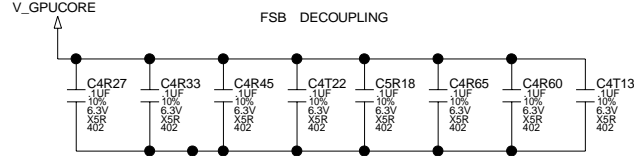
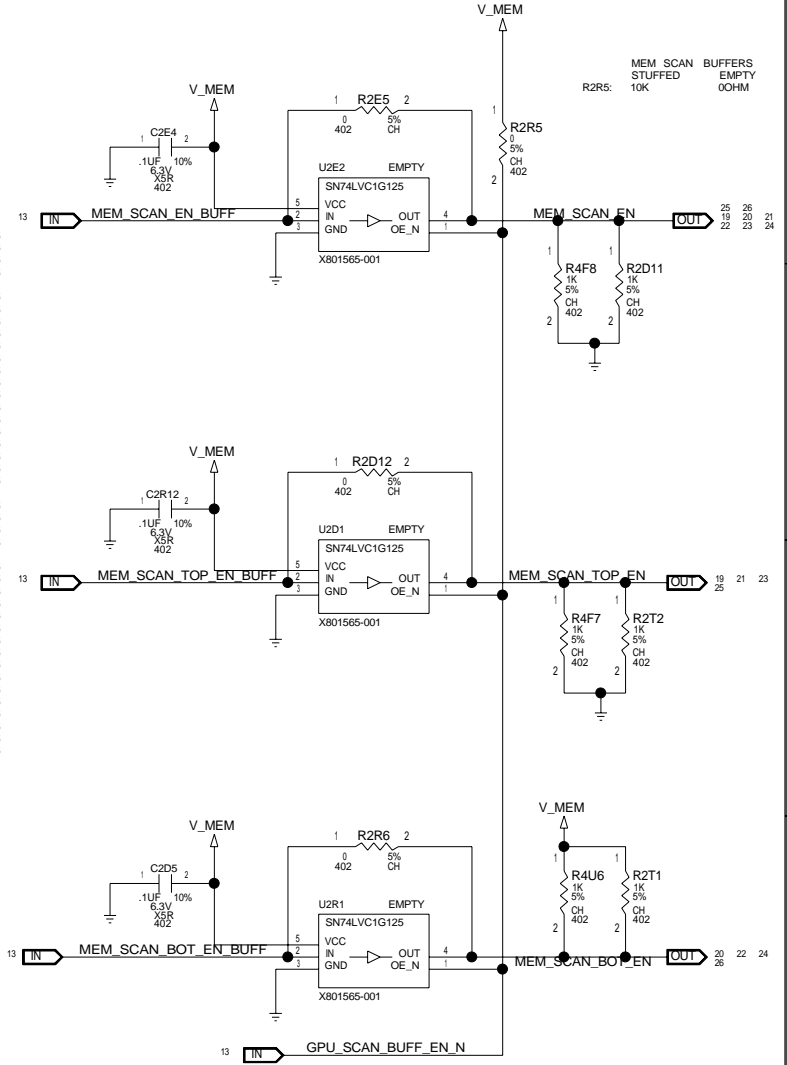
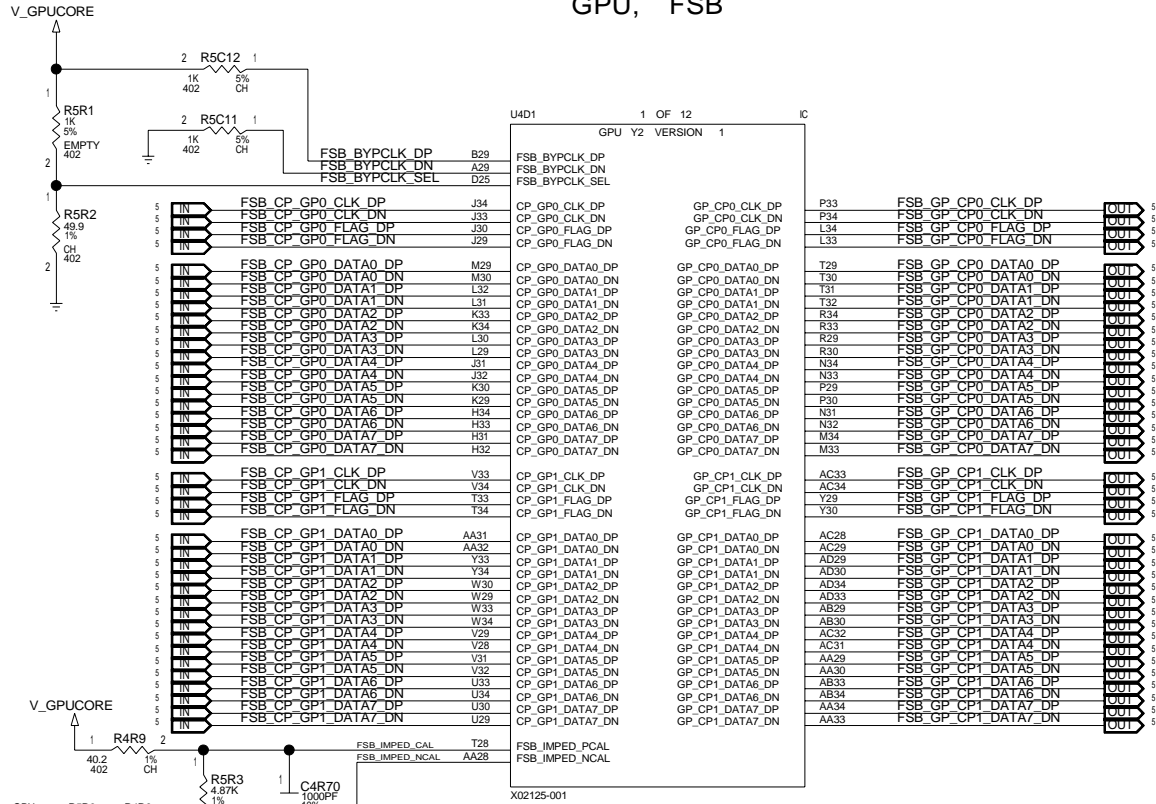

[PAGE_TITLE=GPU, FSB]

DRAWING TONASKET_FAB_A Thu Jan 29 11:46:24 2009

MICROSOFT CONFIDENTIAL	PROJECT NAME H09517	PAGE 12/83	REV A
------------------------	---------------------	------------	-------

GPU, VIDEO + PCIEX + EEPROM + JTAG

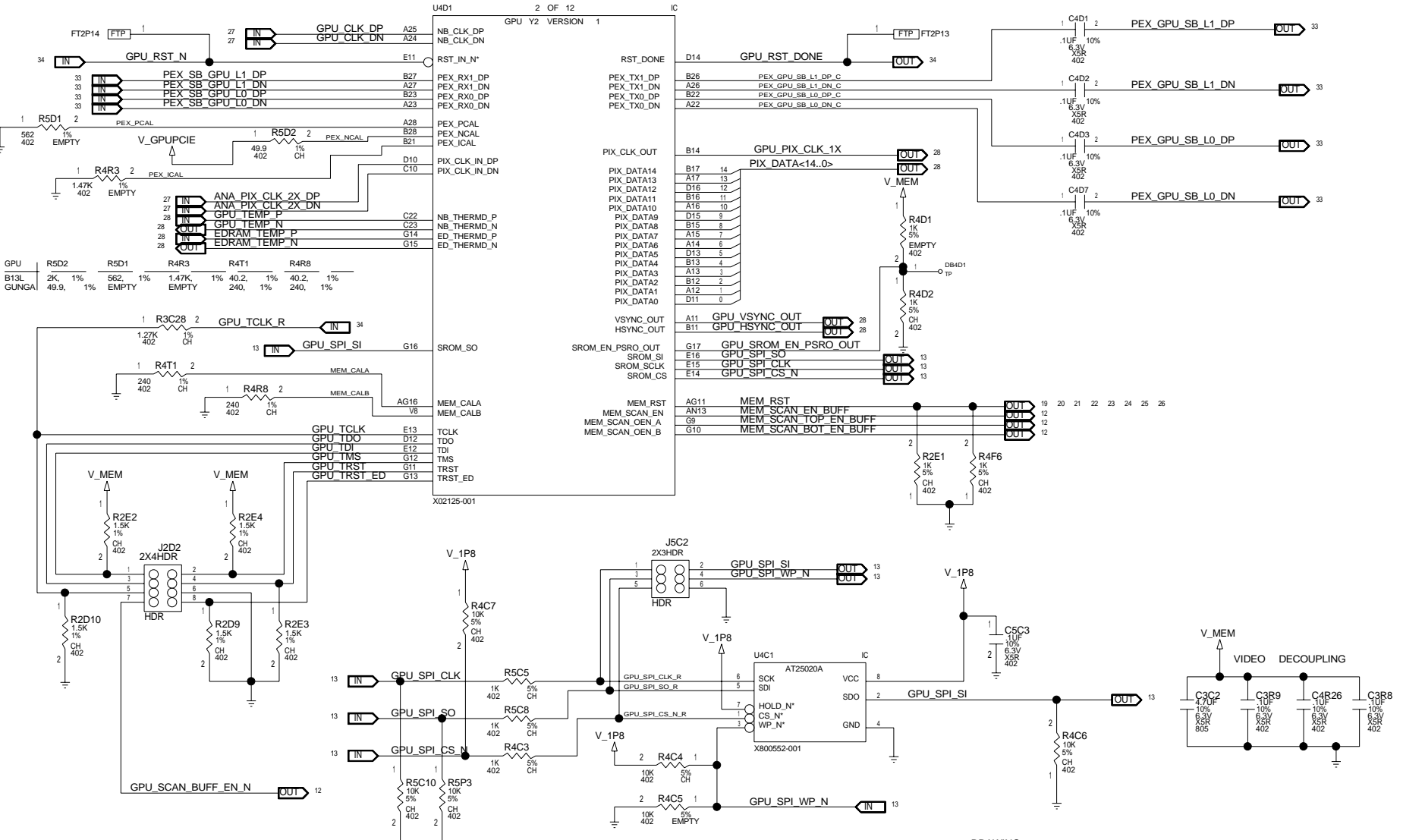

[PAGE_TITLE=GPU, VIDEO + PCIEX + EEPROM + JTAG]

DRAWING
TONASKET_FAB A
Thu Jan 29 11:46:27 2009

MICROSOFT CONFIDENTIAL	PROJECT NAME H09517	PAGE 13/83	REV A
---------------------------	------------------------	---------------	----------

GPU, MEMORY CONTROLLER 0 PARTITION A & B

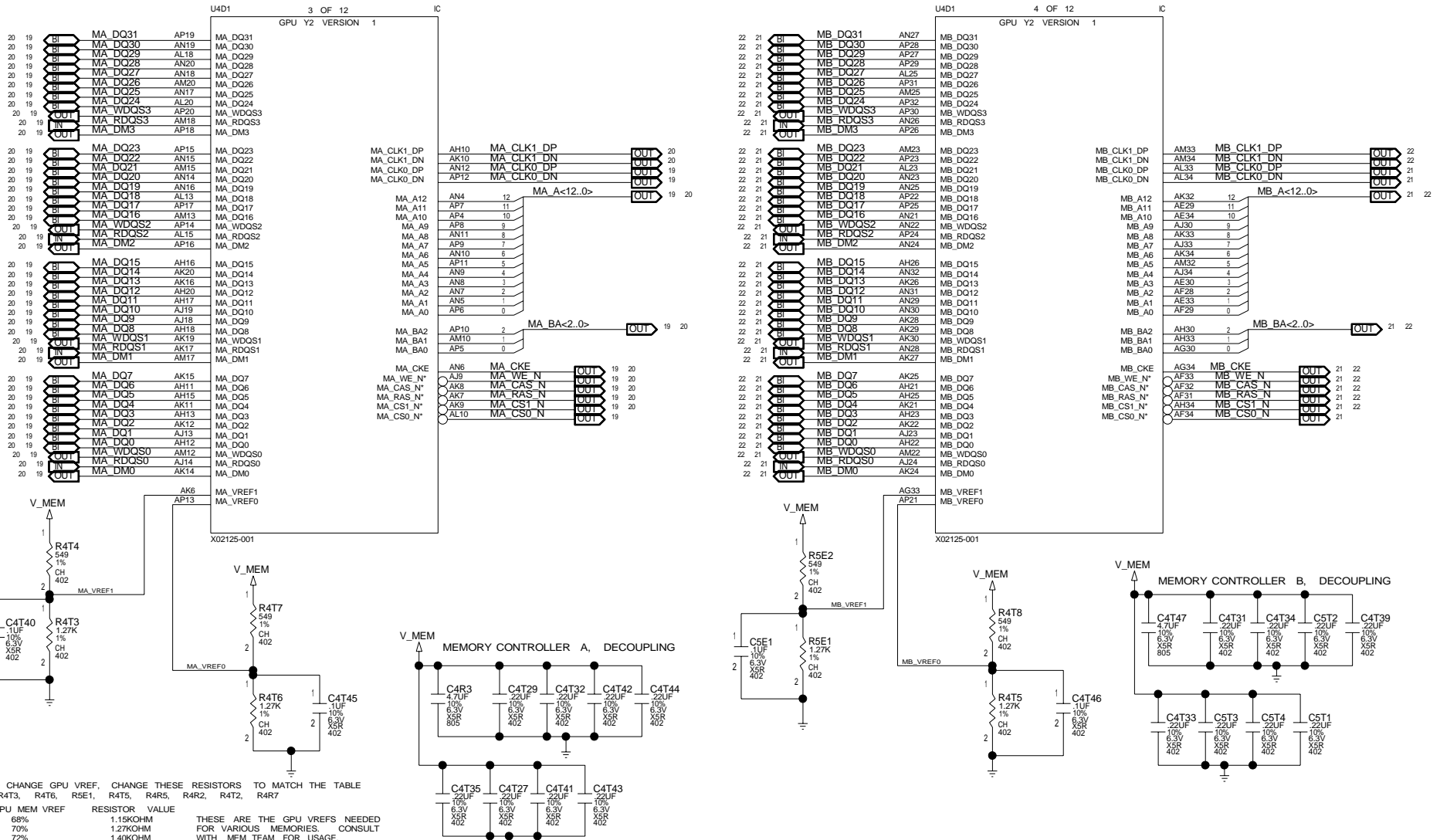

[PAGE_TITLE=GPU, MEMORY CONTROLLER A + B]

DRAWING
TONASKET_FAB_A
Thu Jan 29 11:46:31 2009

MICROSOFT CONFIDENTIAL	PROJECT NAME H09517	PAGE 14/83	REV A
---------------------------	------------------------	---------------	----------

GPU, MEMORY CONTROLLER 1 PARTITION C & D

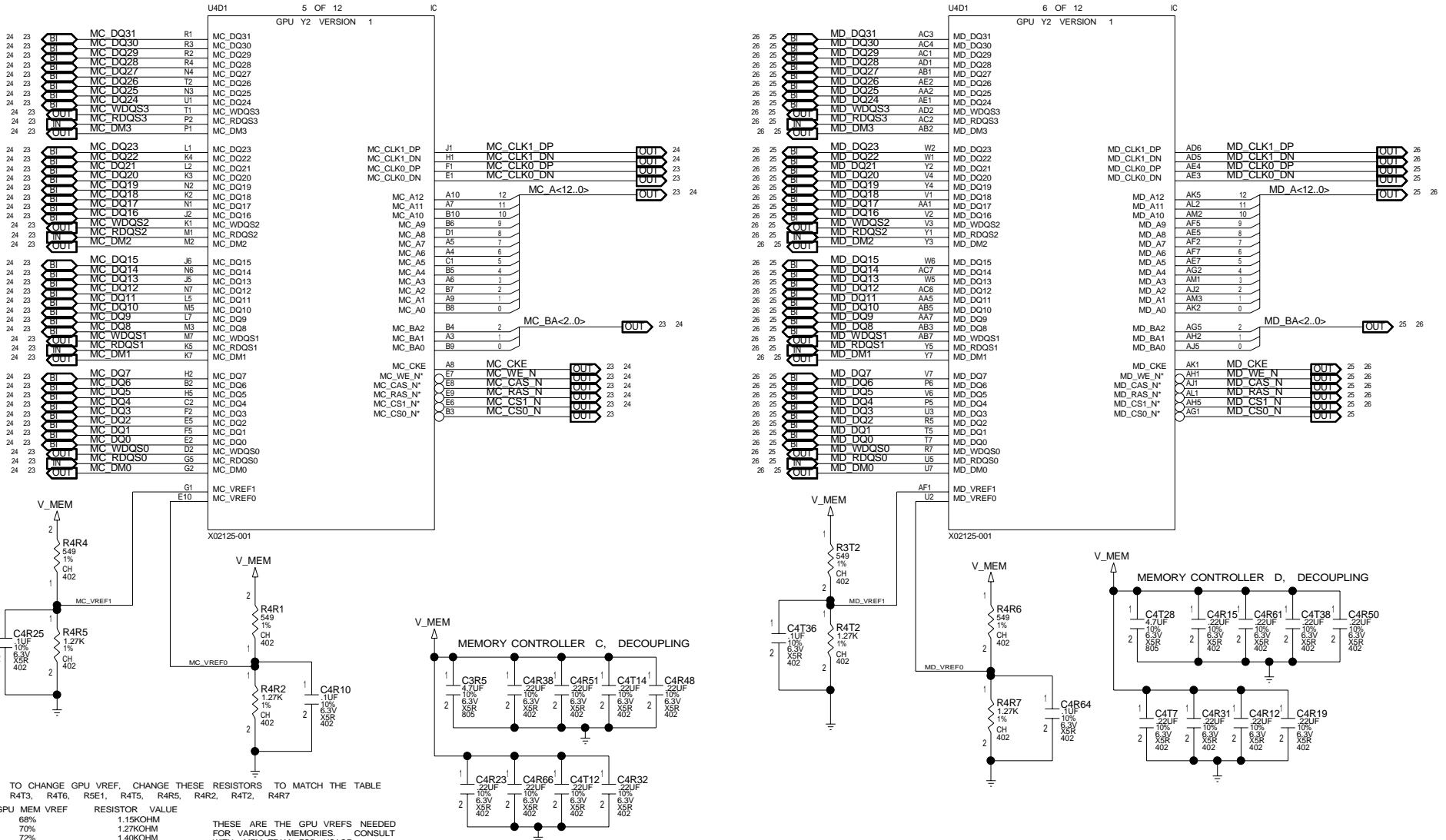

TO CHANGE GPU VREF, CHANGE THESE RESISTORS TO MATCH THE TABLE
R4T3, R4T6, R5E1, R4T5, R4R5, R4R2, R4T2, R4R7

GPU MEM VREF	RESISTOR VALUE
68%	1.15KOHM
70%	1.27KOHM
72%	1.40KOHM
73%	1.47KOHM
74%	1.54KOHM

THESE ARE THE GPU VREFS NEEDED FOR VARIOUS MEMORIES. CONSULT WITH MEM TEAM FOR USAGE.

PAGE_TITLE=[GPU, MEMORY CONTROLLER C + D]

DRAWING
TONASKET_FAB_A
Thu Jan 29 11:46:35 2009

MICROSOFT CONFIDENTIAL	PROJECT NAME H09517	PAGE 15/83	REV A
---------------------------	------------------------	---------------	----------

GPU, PLL POWER + FSB POWER

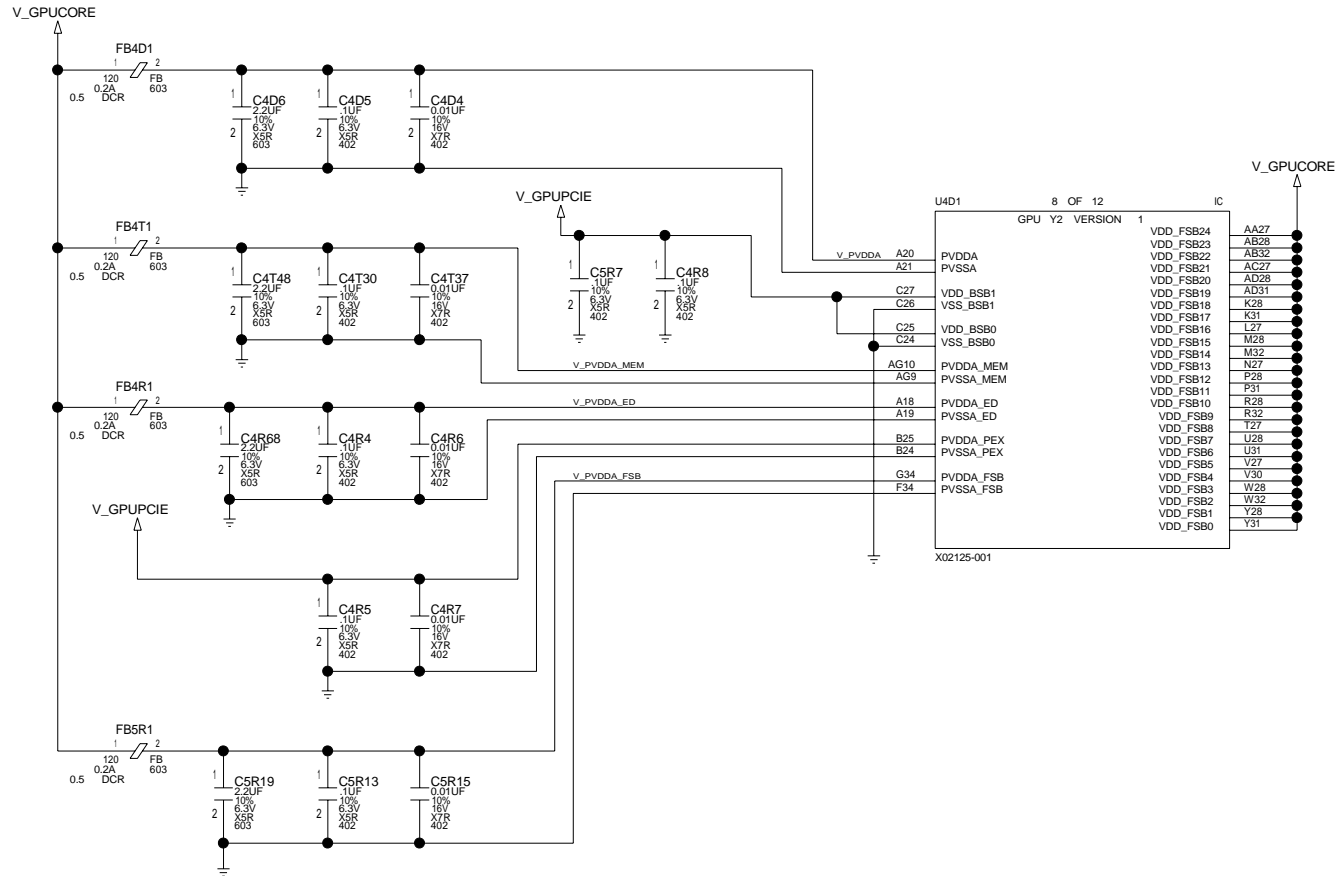

GPU, CORE POWER + MEM POWER

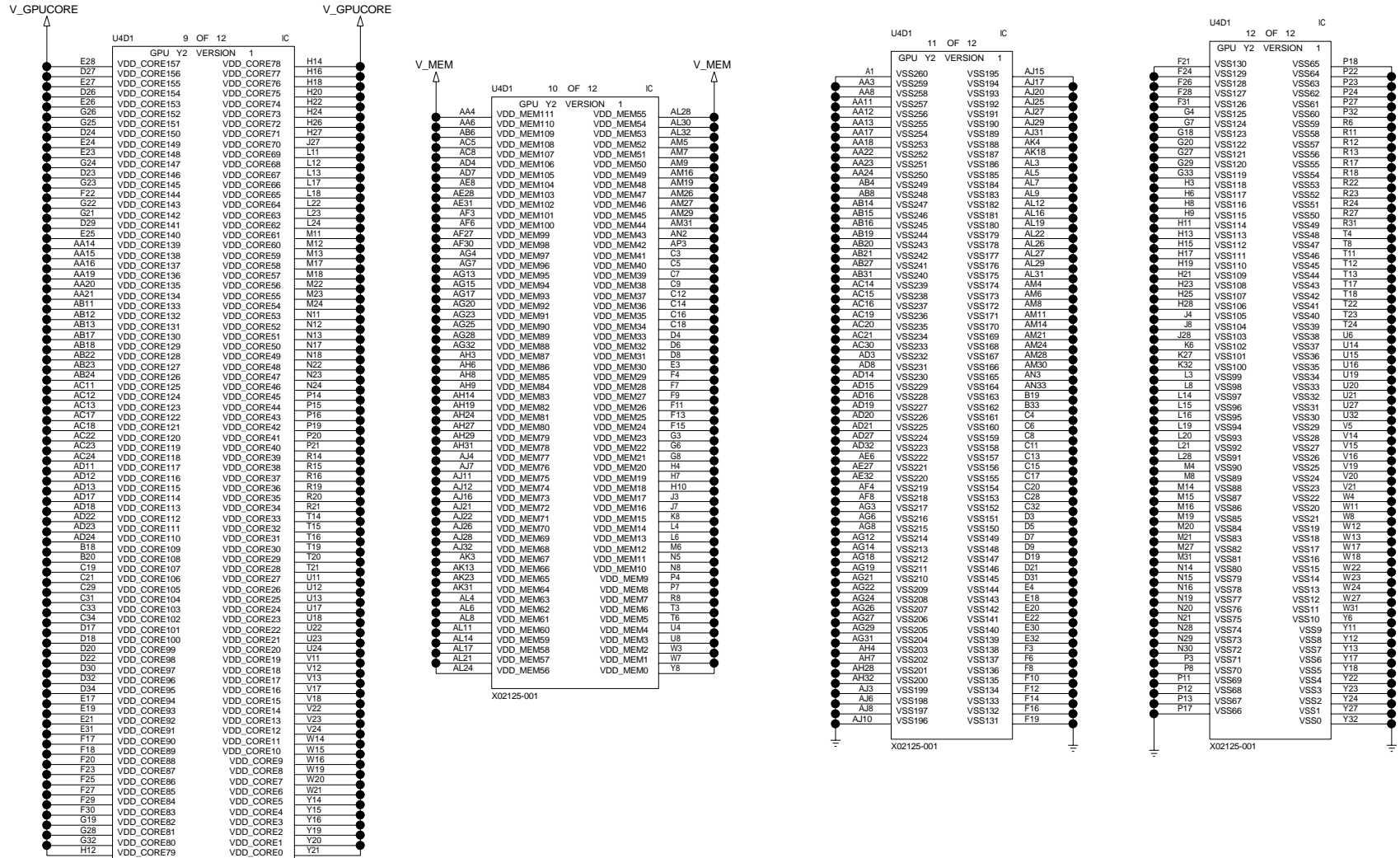

[PAGE_TITLE=GPU, CORE POWER + MEM POWER]

DRAWING TONASKET FAB A Thu Jan 29 11:46:41

2009	MICROSOFT CONFIDENTIAL	PROJECT NAME H09517	PAGE 17/83	REV A
------	------------------------	---------------------	------------	-------

GPU, DECOUPLING

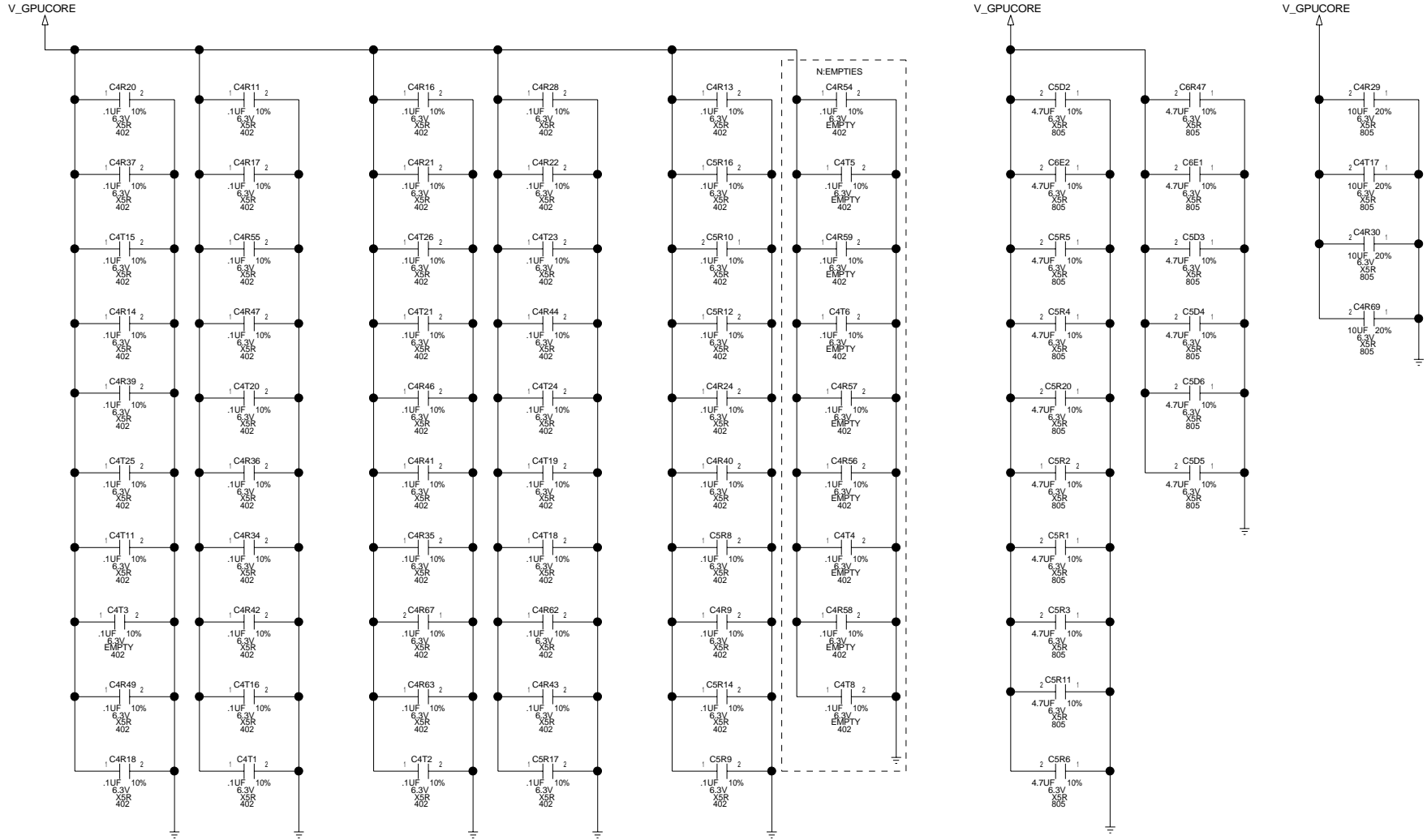

[PAGE_TITLE=GPU, DECOUPLING]

DRAWING
TONASKET_FAB_A
Thu Jan 29 11:46:43

2009	MICROSOFT CONFIDENTIAL	PROJECT NAME H09517	PAGE 18/83	REV A
------	---------------------------	------------------------	---------------	----------

MEMORY PARTITION A, TOP

CHIP SELECT = 0, MIRROR FUNCTION = 0

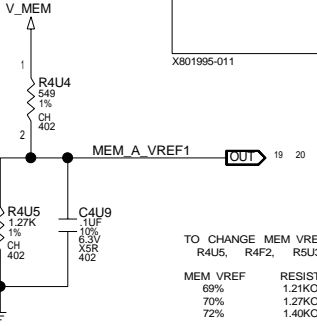
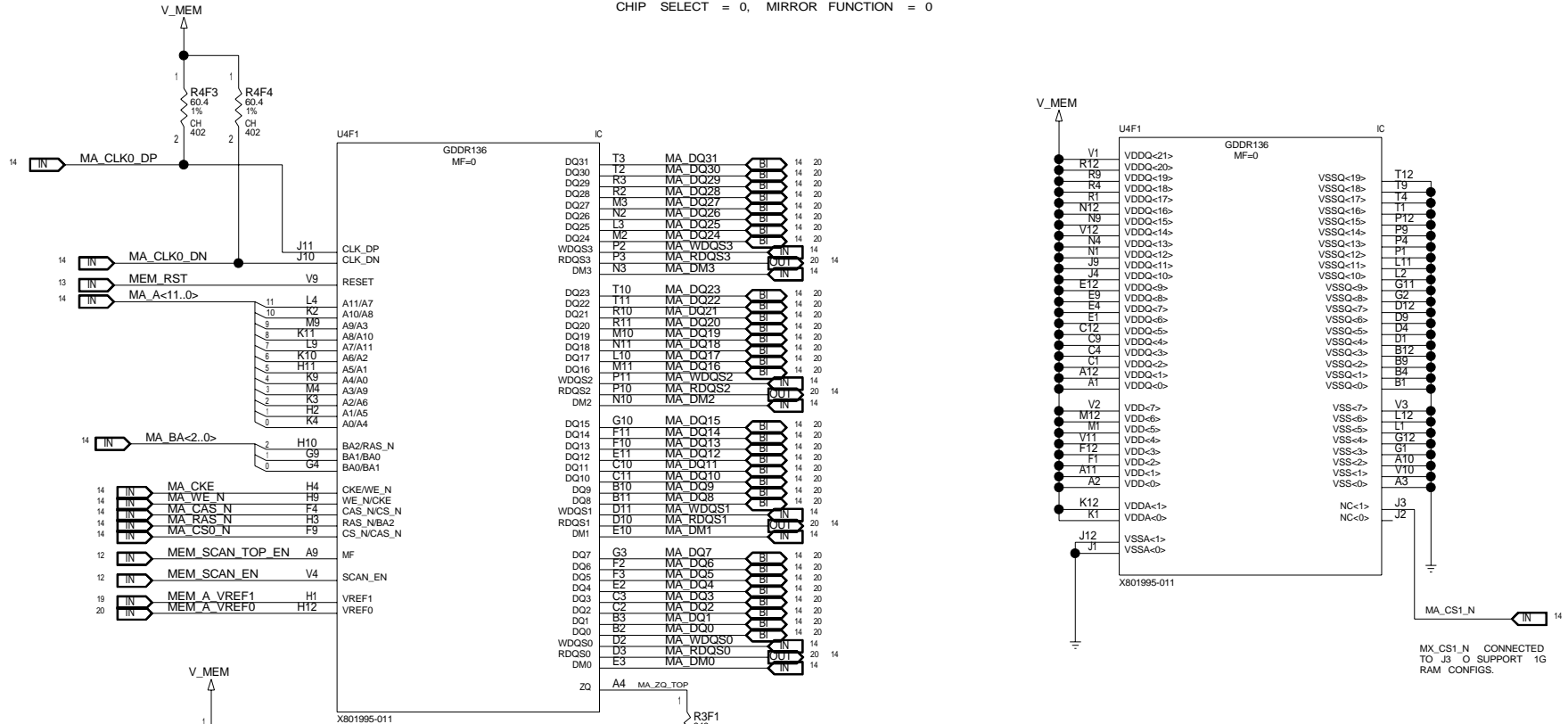

TO CHANGE MEM VREF, CHANGE THESE RESISTORS TO MATCH THE TABLE

MEM VREF	RESISTOR VALUE
69%	1.21KOHM
70%	1.27KOHM
72%	1.40KOHM

THESE ARE THE MEM VREFS NEEDED FOR VARIOUS MEMORIES. CONSULT WITH MEM TEAM FOR USAGE.

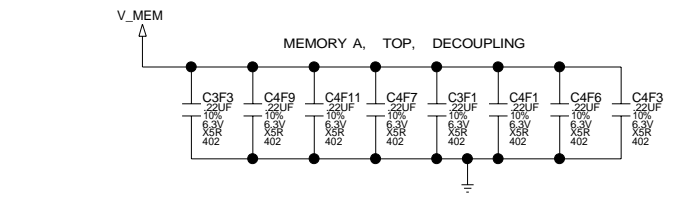
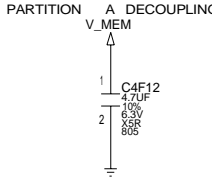

MEMORY PARTITION A, BOTTOM

CHIP SELECT = 1, MIRROR FUNCTION = 1

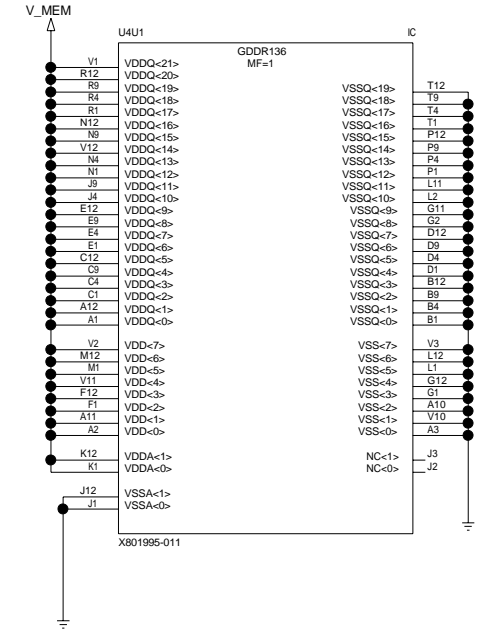
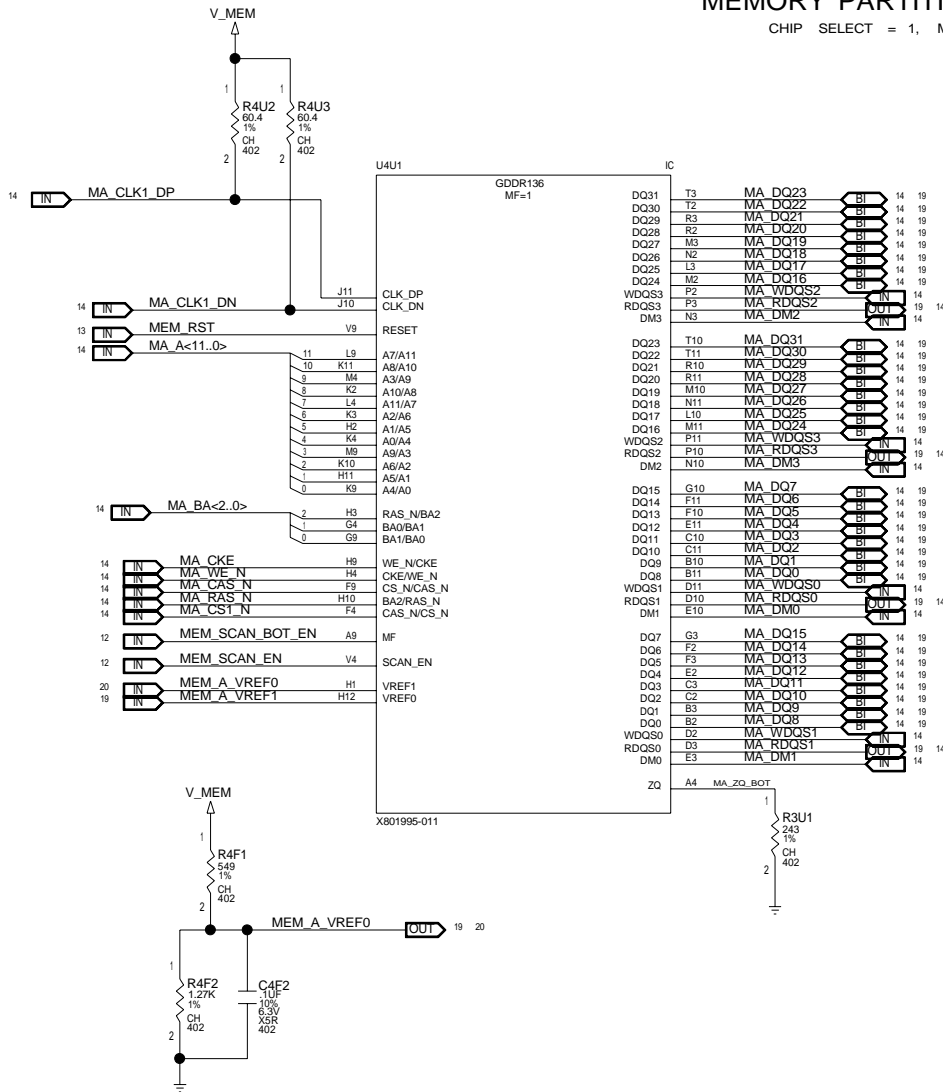

MEMORY PARTITION B, TOP

CHIP SELECT = 0, MIRROR FUNCTION = 0

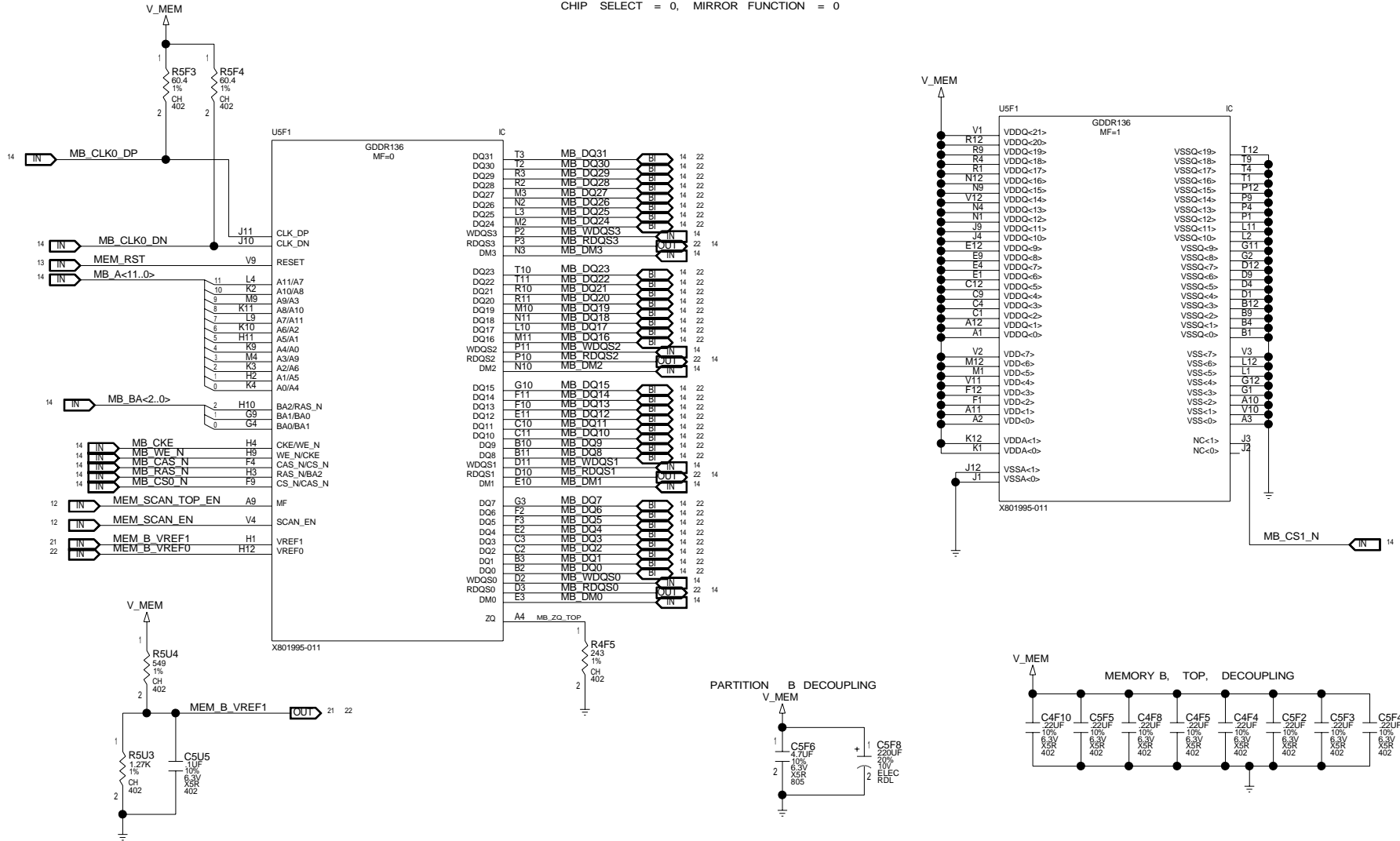

[PAGE_TITLE=MEMORY PARTITION A, BOTTOM]

DRAWING
TONASKET_FAB_A
Thu Jan 29 11:46:52 2009

MICROSOFT CONFIDENTIAL	PROJECT NAME H09517	PAGE 21/83	REV A
---------------------------	------------------------	---------------	----------

MEMORY PARTITION B, BOTTOM

CHIP SELECT = 1, MIRROR FUNCTION = 1

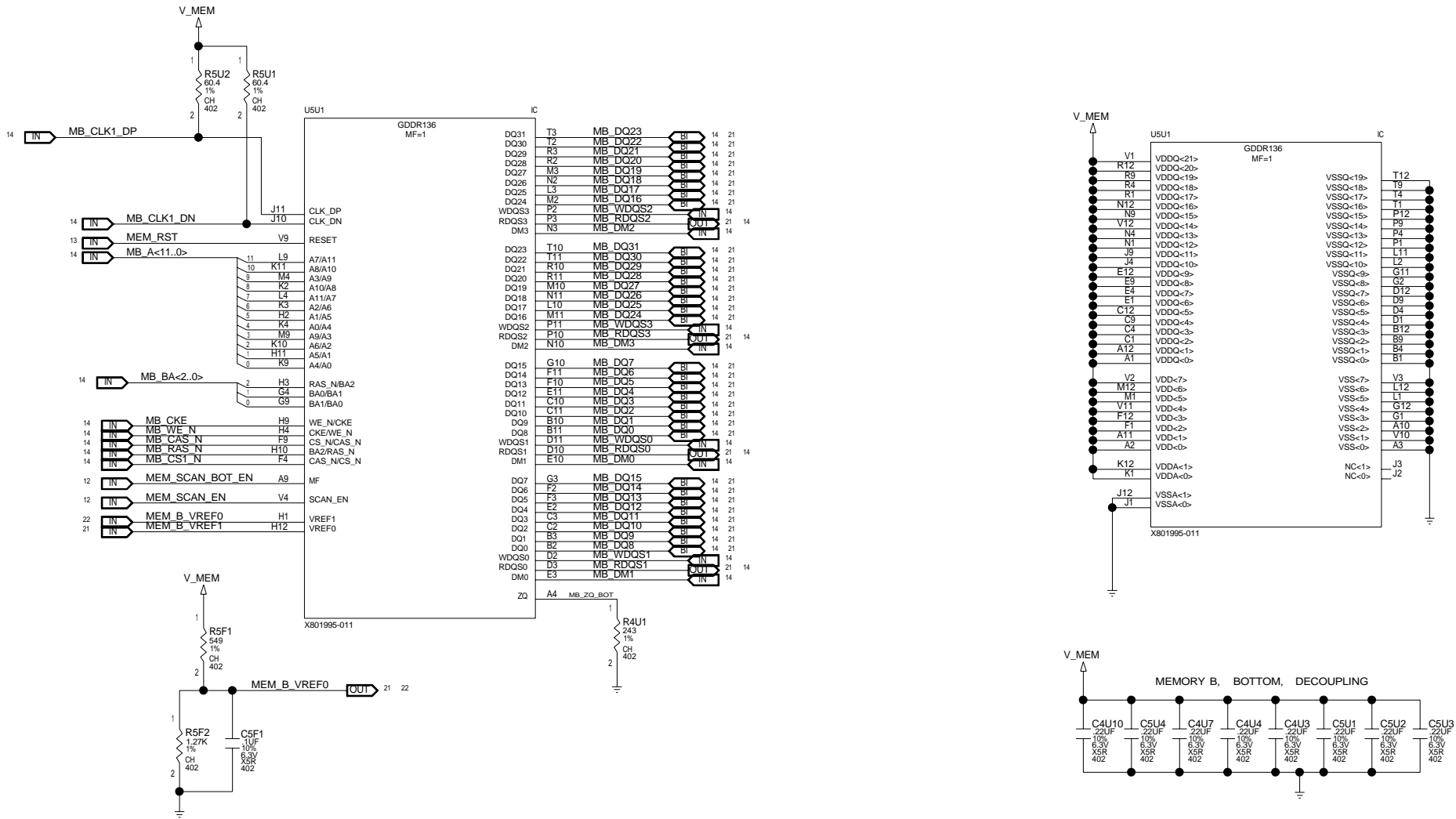

[PAGE_TITLE=MEMORY PARTITION B, TOP]

DRAWING
TONASKET_FAB_A
Thu Jan 29 11:46:54 2009

MICROSOFT CONFIDENTIAL	PROJECT NAME H09517	PAGE 22/83	REV A
---------------------------	------------------------	---------------	----------

MEMORY PARTITION C, TOP

CHIP SELECT = 0, MIRROR FUNCTION = 0

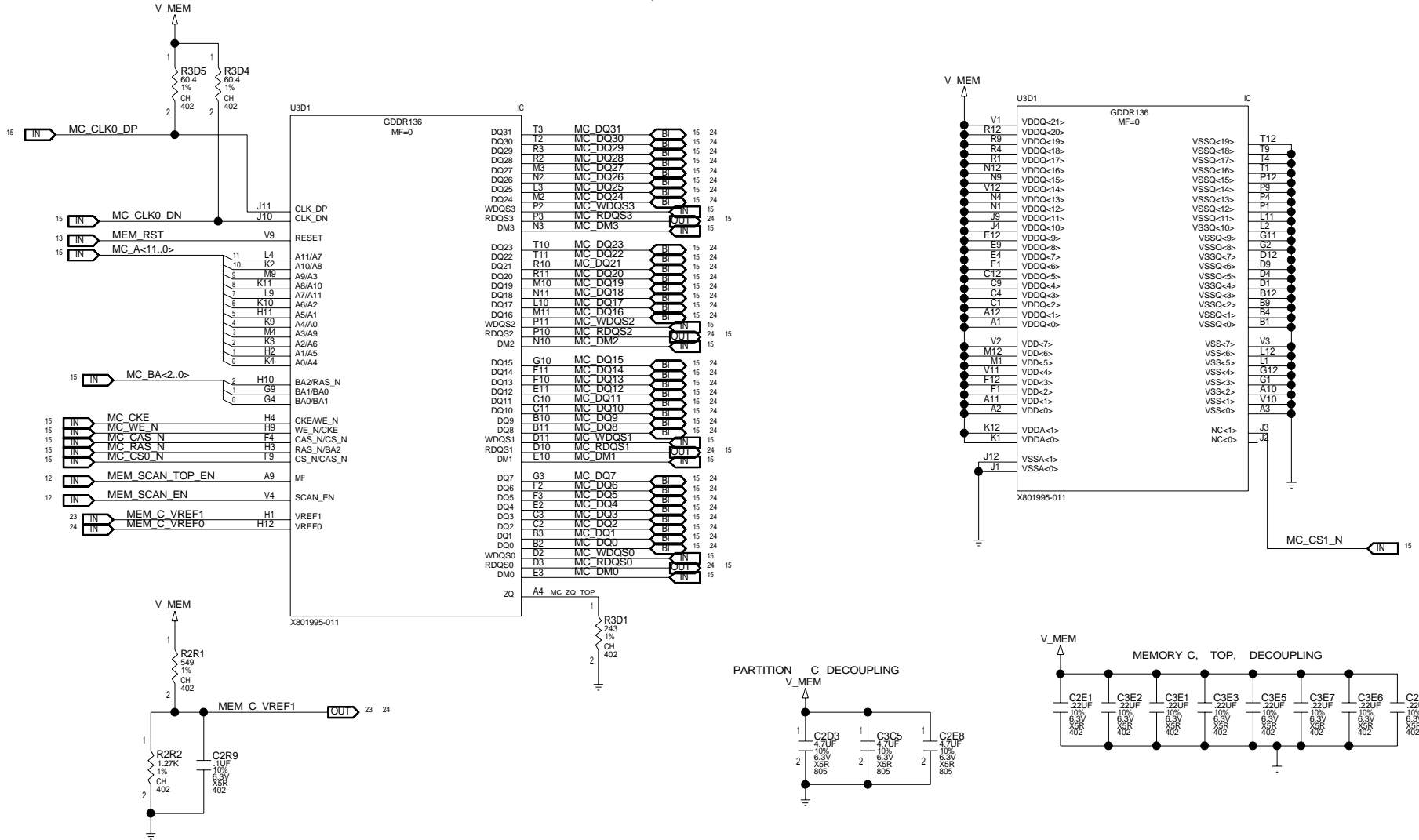

[PAGE_TITLE=MEMORY PARTITION B, BOTTOM]

DRAWING
TONASKET_FAB_A
Thu Jan 29 11:46:57 2009

MICROSOFT CONFIDENTIAL	PROJECT NAME H09517	PAGE 23/83	REV A
---------------------------	------------------------	---------------	----------

MEMORY PARTITION C, BOTTOM

CHIP SELECT = 1, MIRROR FUNCTION = 1

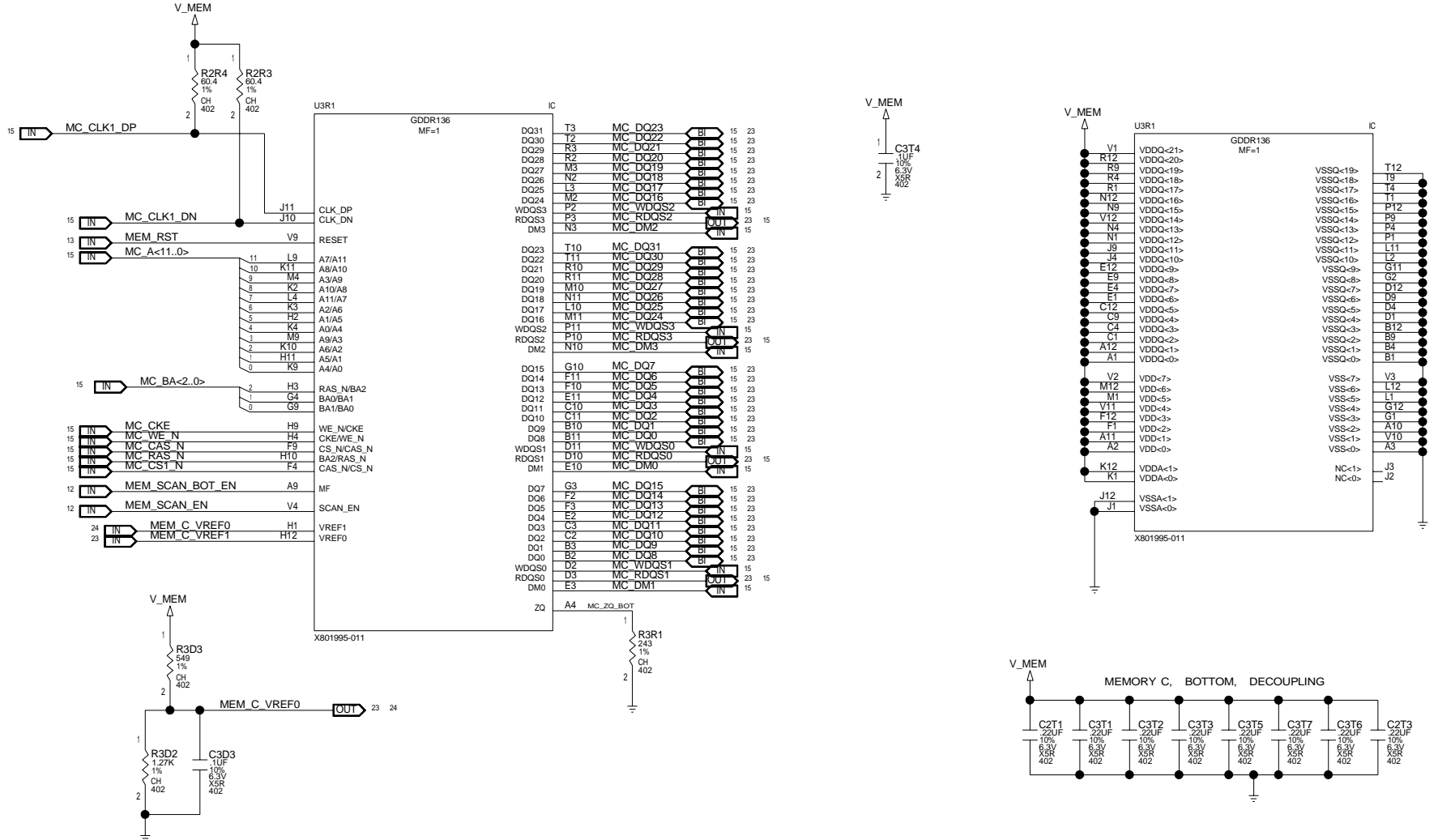

[PAGE_TITLE=MEMORY PARTITION C, TOP]

MEMORY PARTITION D, BOTTOM

CHIP SELECT = 1, MIRROR FUNCTION = 1

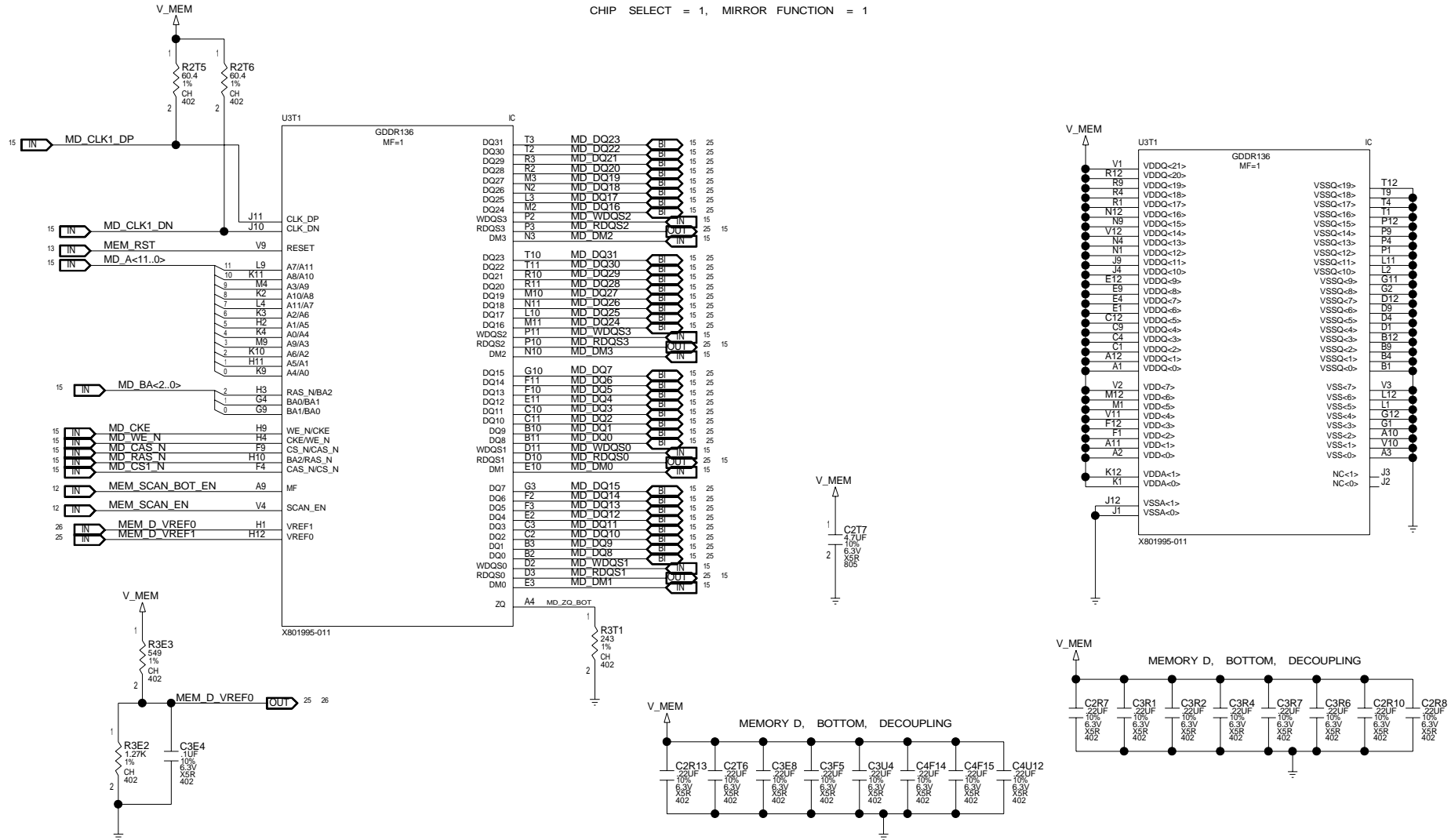

HANA, CLOCKS + STRAPPING

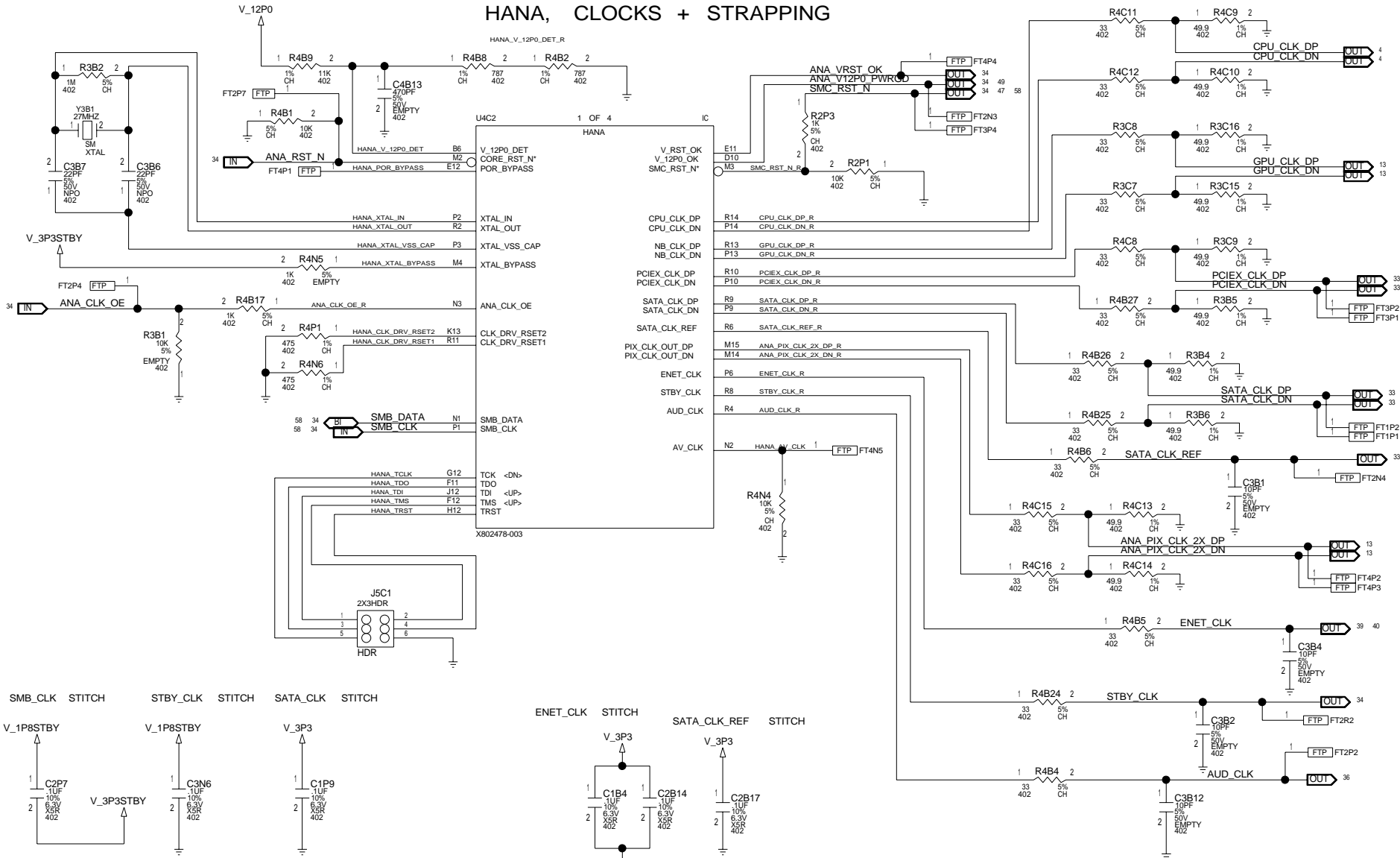

[PAGE_TITLE=HANA, CLOCKS + STRAPPING]

HANA, VIDEO + FAN + JTAG

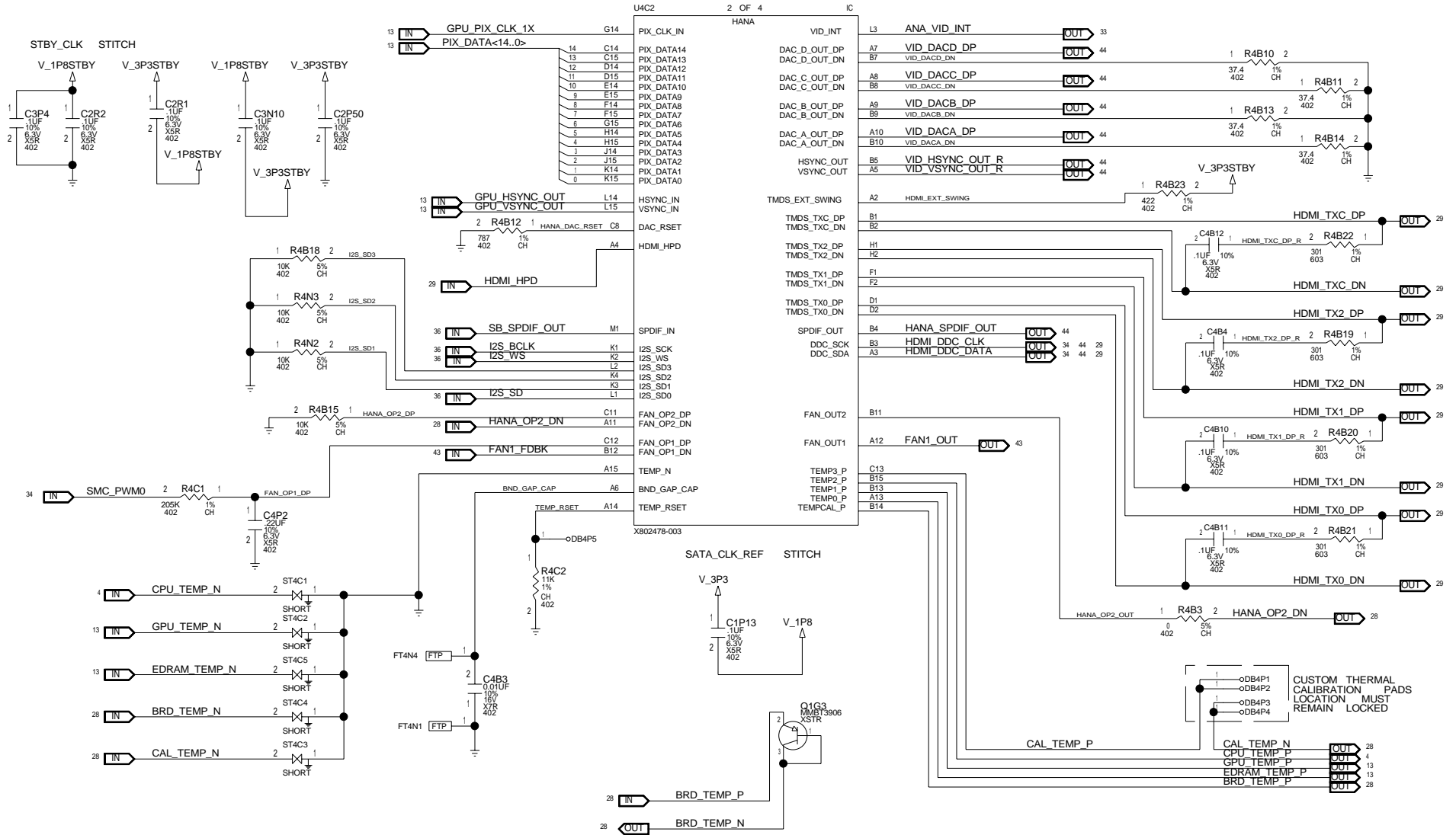

[PAGE_TITLE=HANA, VIDEO + FAN + JTAG]

DRAWING
TONASKET_FAB_A
Thu Jan 29 11:47:08 2009

MICROSOFT CONFIDENTIAL	PROJECT NAME H09517	PAGE 28/83	REV A
---------------------------	------------------------	---------------	----------

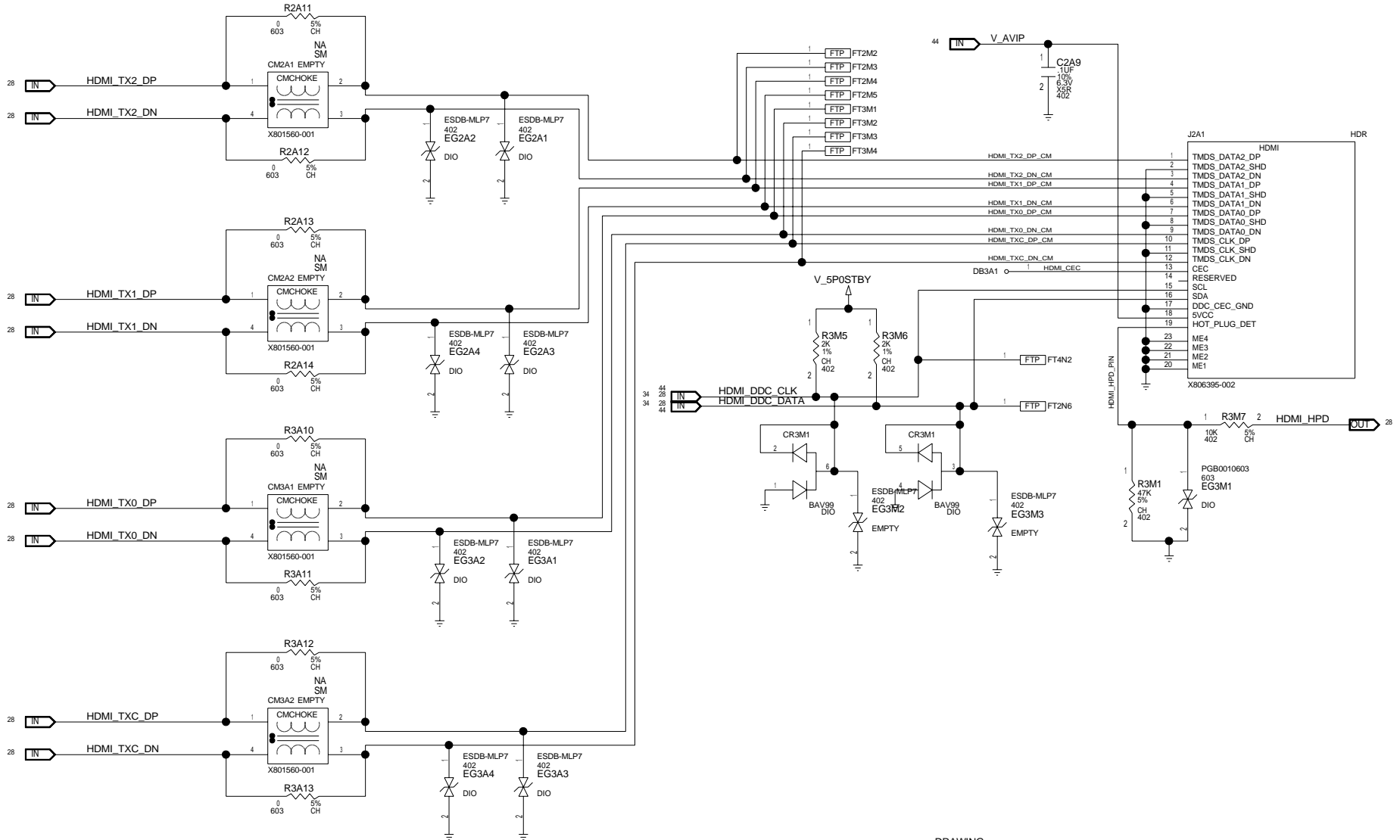

[PAGE_TITLE=CONN, HDMI]

DRAWING
 TONASKET_FAB_A
 Thu Jan 29 11:47:09 2009

MICROSOFT CONFIDENTIAL	PROJECT NAME H09517	PAGE 29/83	REV A
---------------------------	------------------------	---------------	----------

HANA, POWER + DECOUPLING

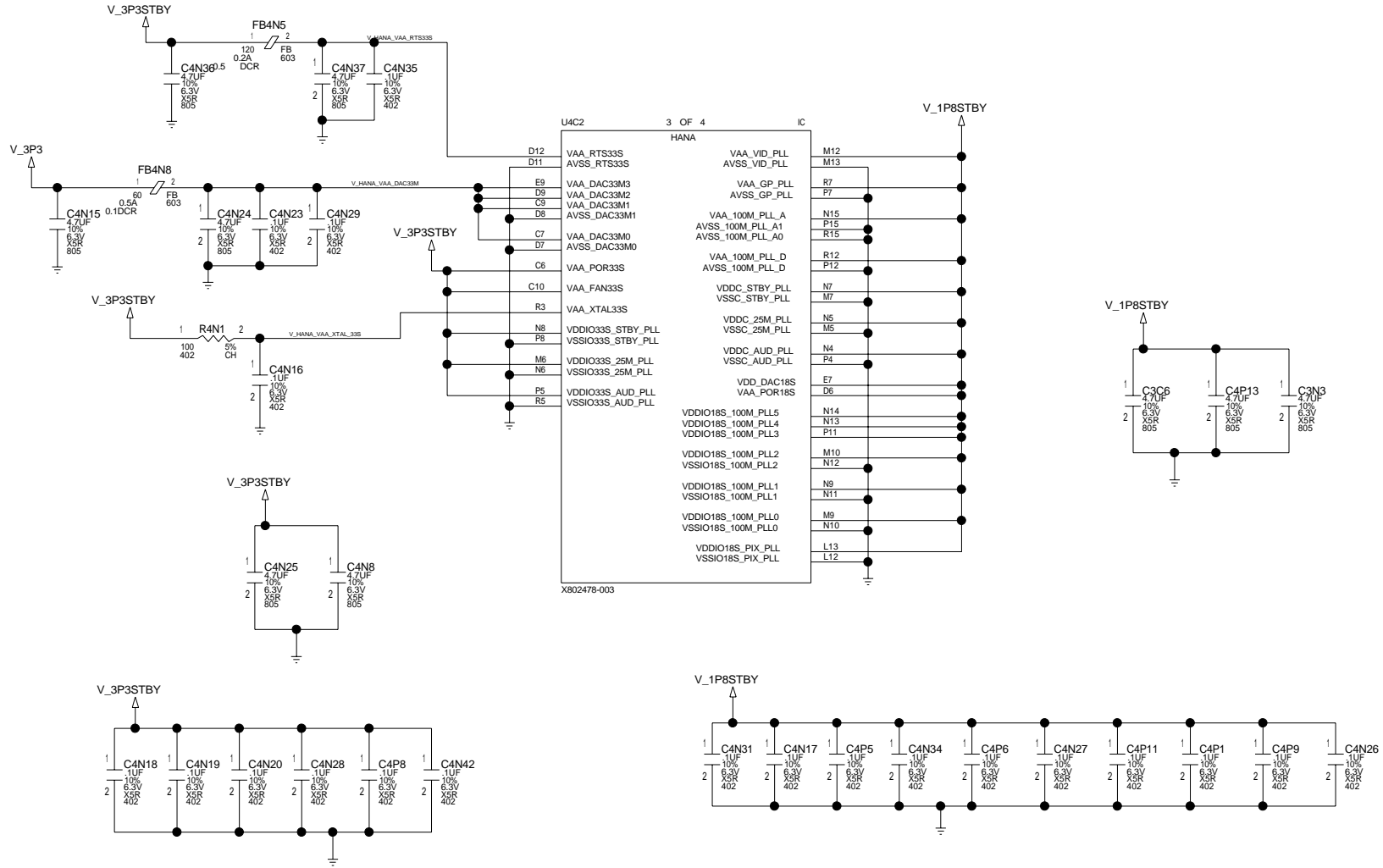

[PAGE_TITLE=HANA, POWER + DECOUPLING]

DRAWING
TONASKET_FAB_A
Thu Jan 29 11:47:10 2009

MICROSOFT CONFIDENTIAL	PROJECT NAME H09517	PAGE 30/83	REV A
---------------------------	------------------------	---------------	----------

HANA, POWER + DECOUPLING

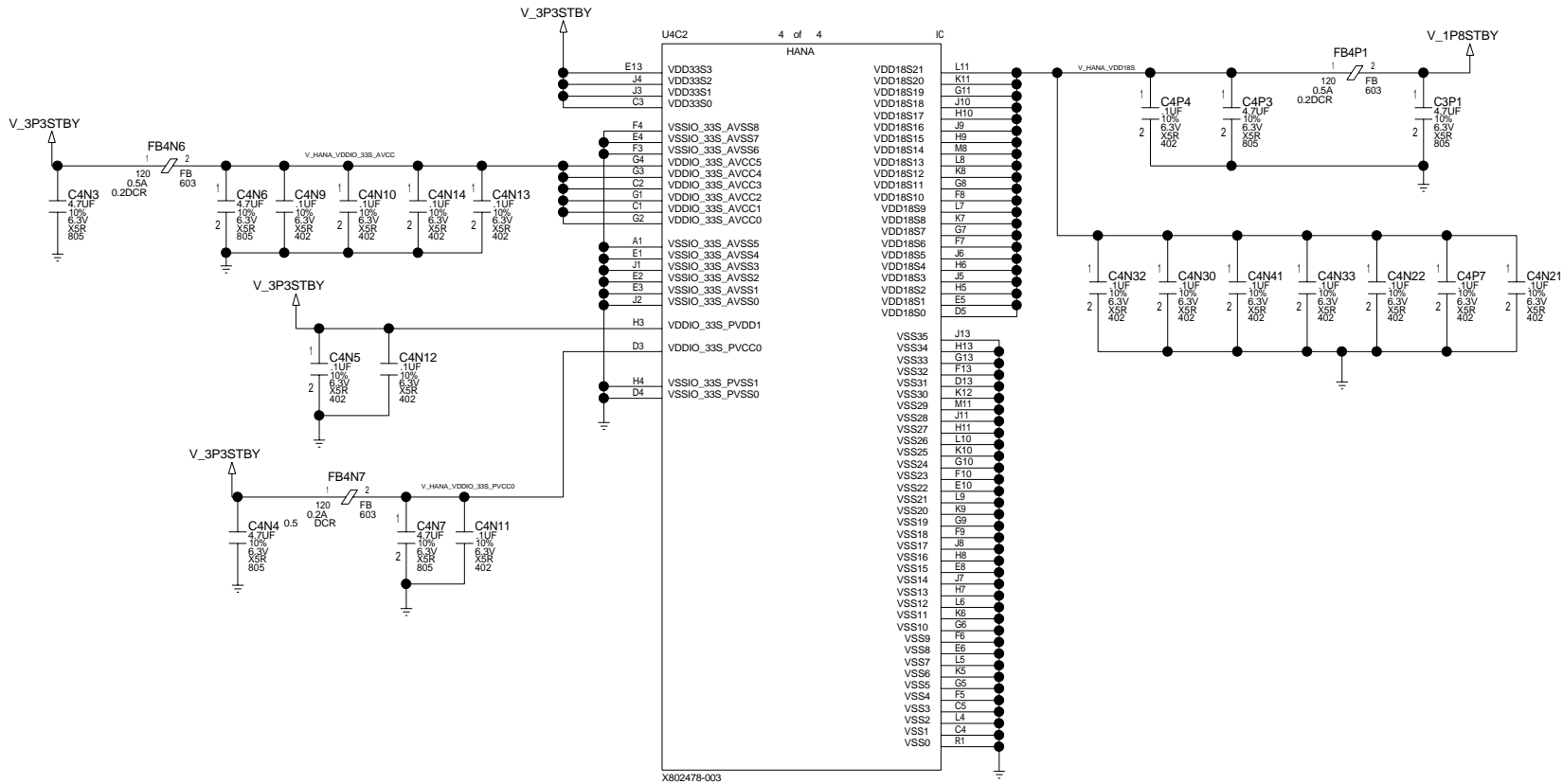

POWER TRACE DECOUPLING

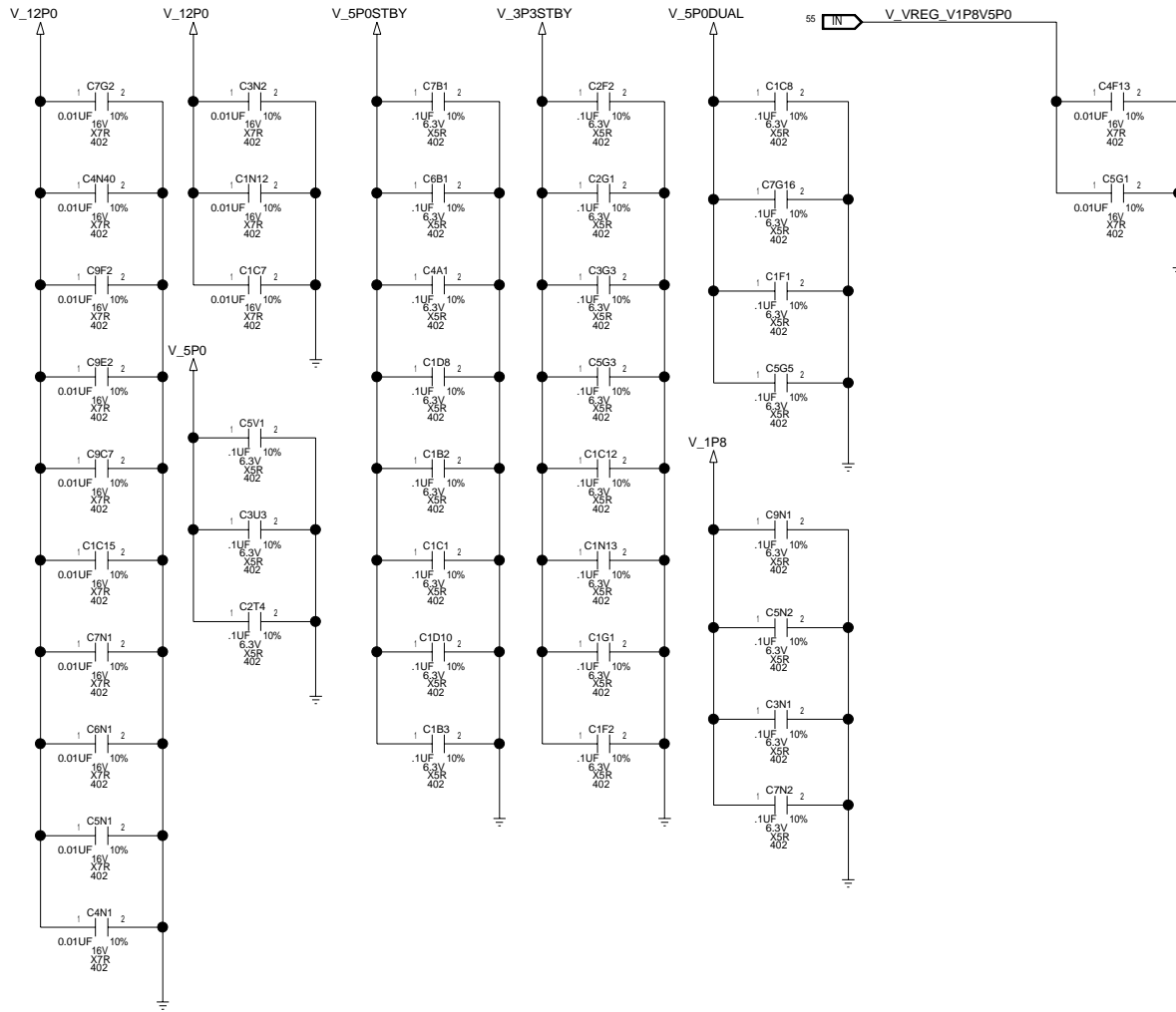

ADB:ADD CONFIG TABLE

SB, PCIEX + SMM GPIO + JTAG

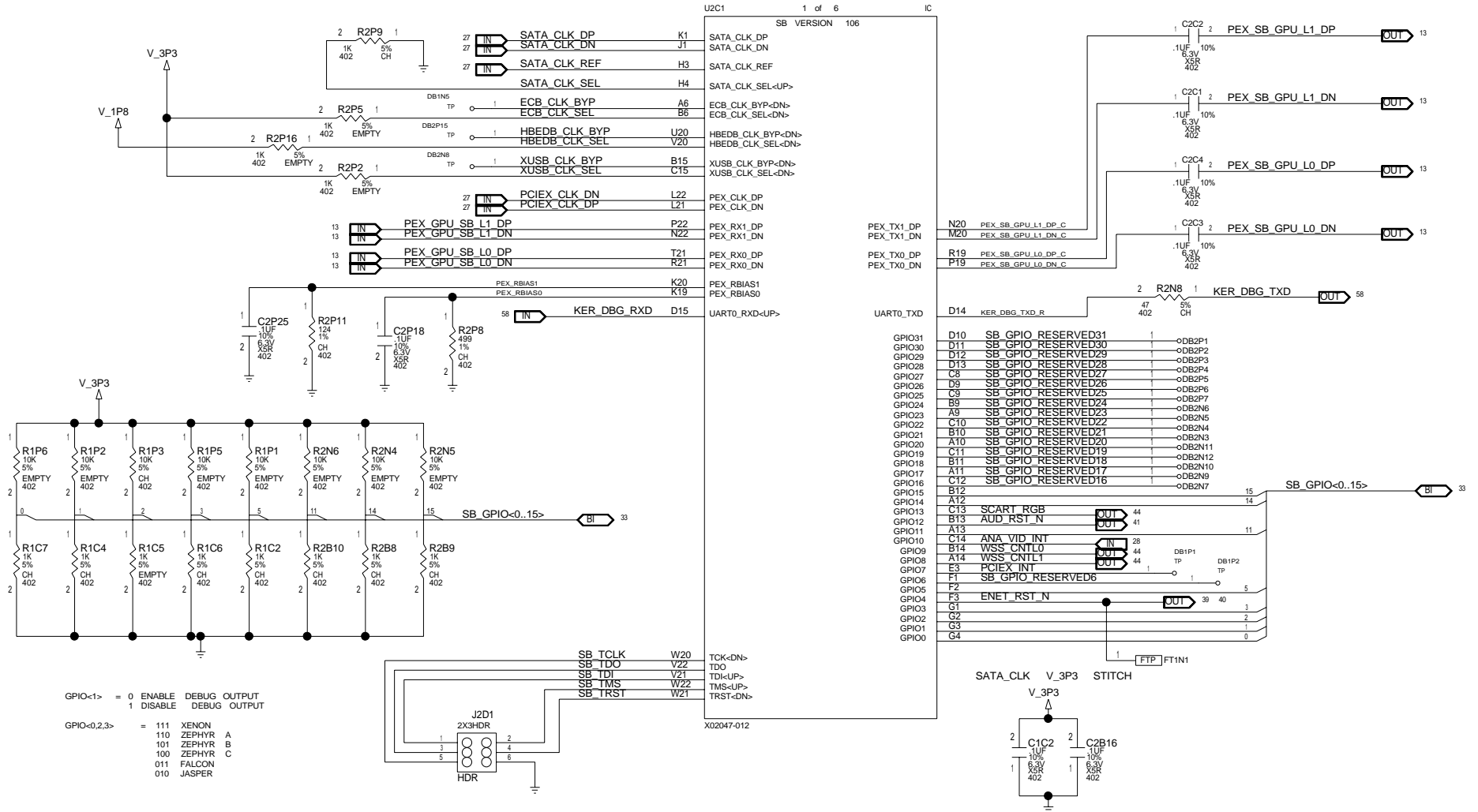

[PAGE_TITLE=SB, PCIEX + SMM GPIO + JTAG]

DRAWING
 TONASKET_FAB_A
 Thu Jan 29 11:47:15 2009

MICROSOFT CONFIDENTIAL	PROJECT NAME H09517	PAGE 33/83	REV A
---------------------------	------------------------	---------------	----------

SB, SMC

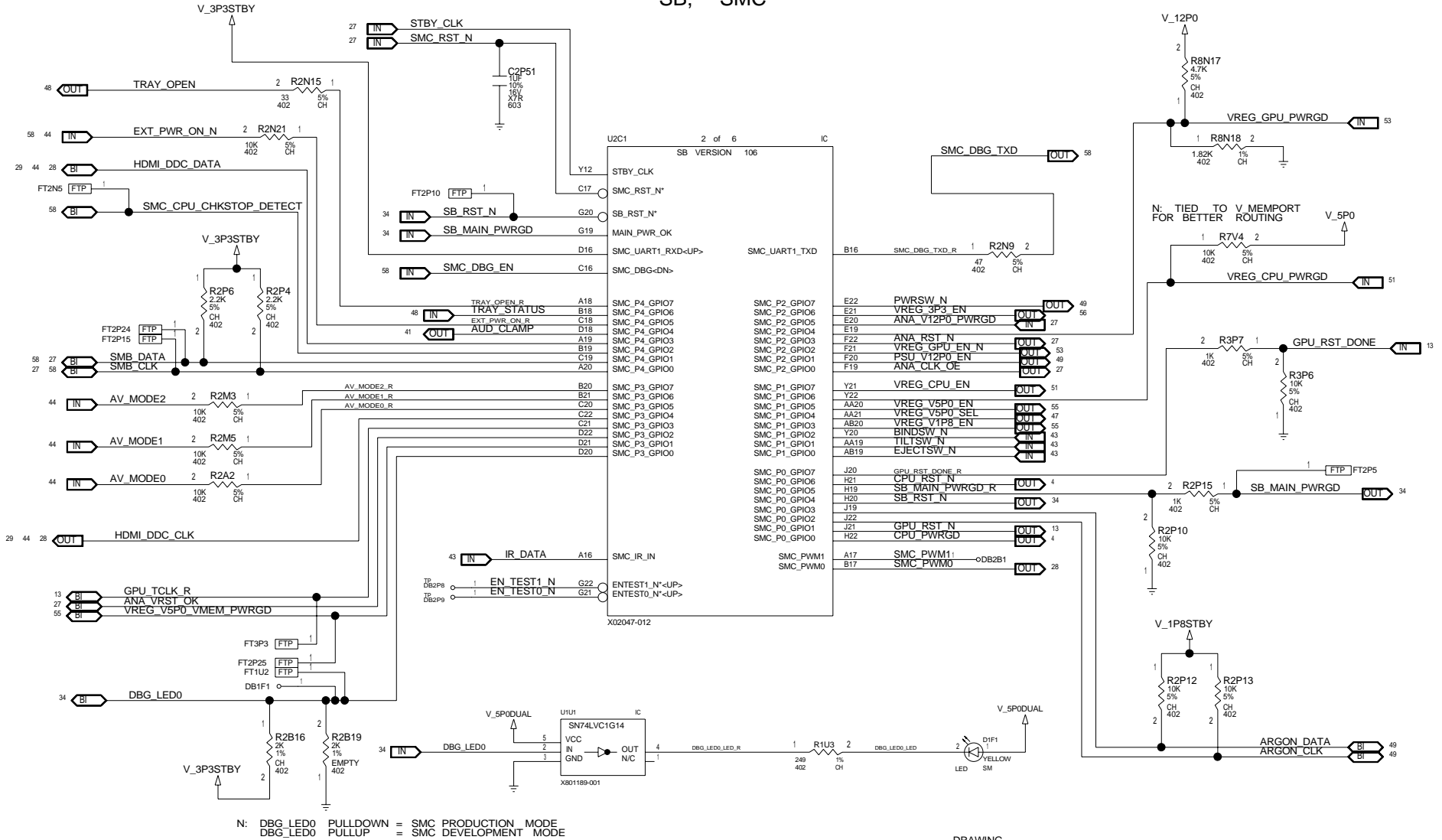

[PAGE_TITLE=SB, SMC]

DRAWING
 TONASKET_FAB_A
 Thu Jan 29 11:47:18

2009

MICROSOFT CONFIDENTIAL	PROJECT NAME H09517	PAGE 34/83	REV A
---------------------------	------------------------	---------------	----------

SB, FLASH + USB + SPI

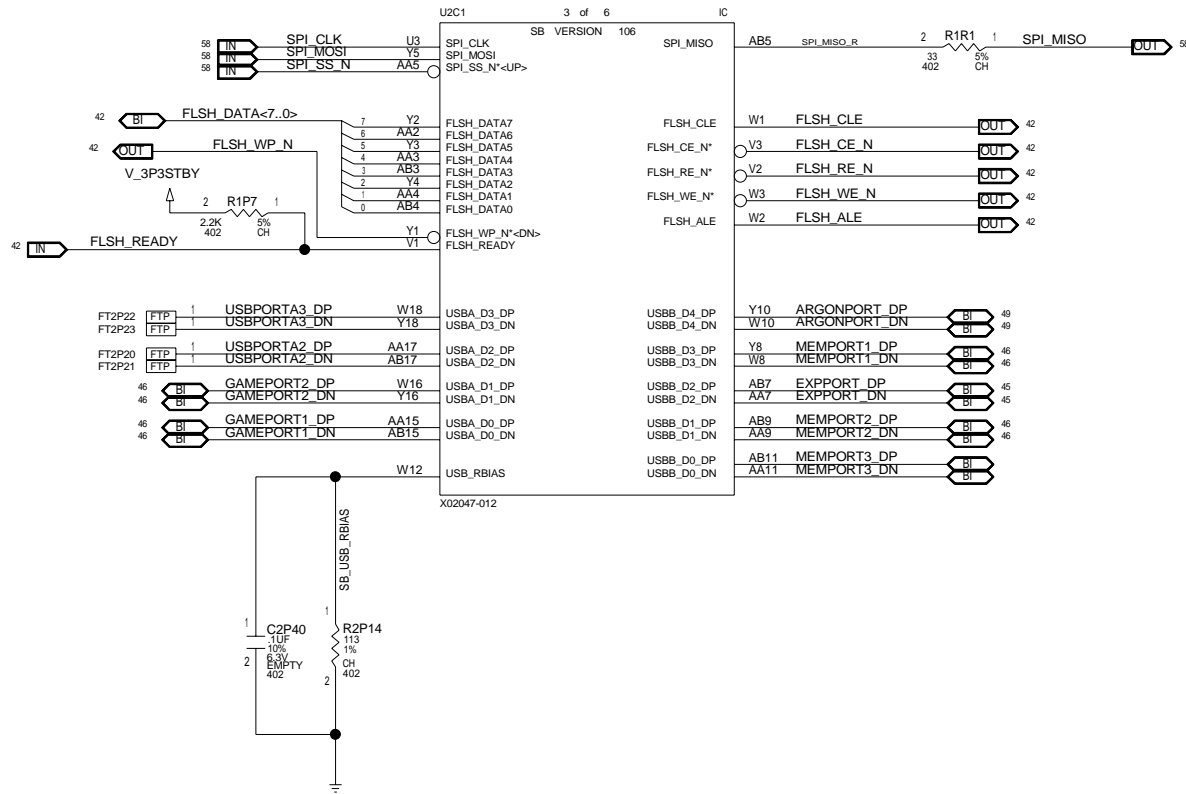

SB, ETHERNET + AUDIO + SATA

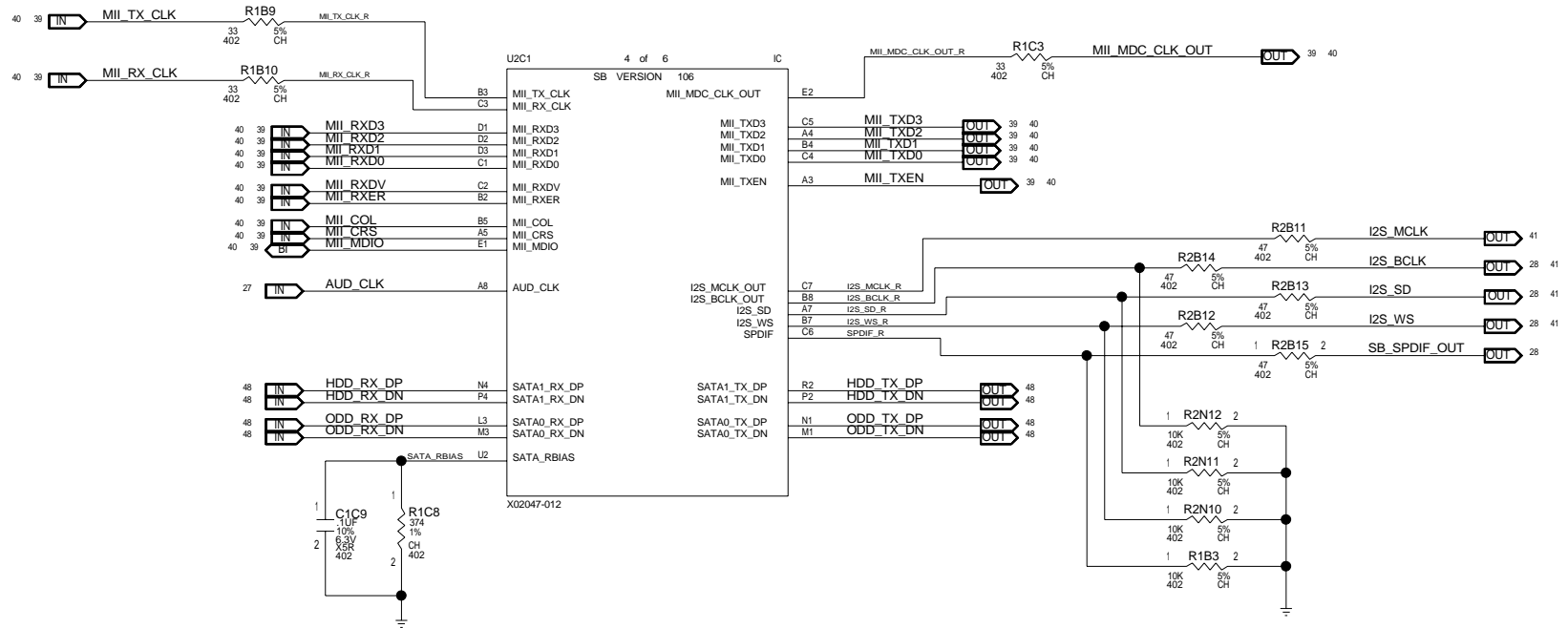

[PAGE_TITLE=SB, ETHERNET + AUDIO + SATA]

DRAWING
TONASKET_FAB_A
Thu Jan 29 11:47:21 2009

MICROSOFT CONFIDENTIAL	PROJECT NAME H09517	PAGE 36/83	REV A
---------------------------	------------------------	---------------	----------

SB, STANDBY POWER + DECOUPLING

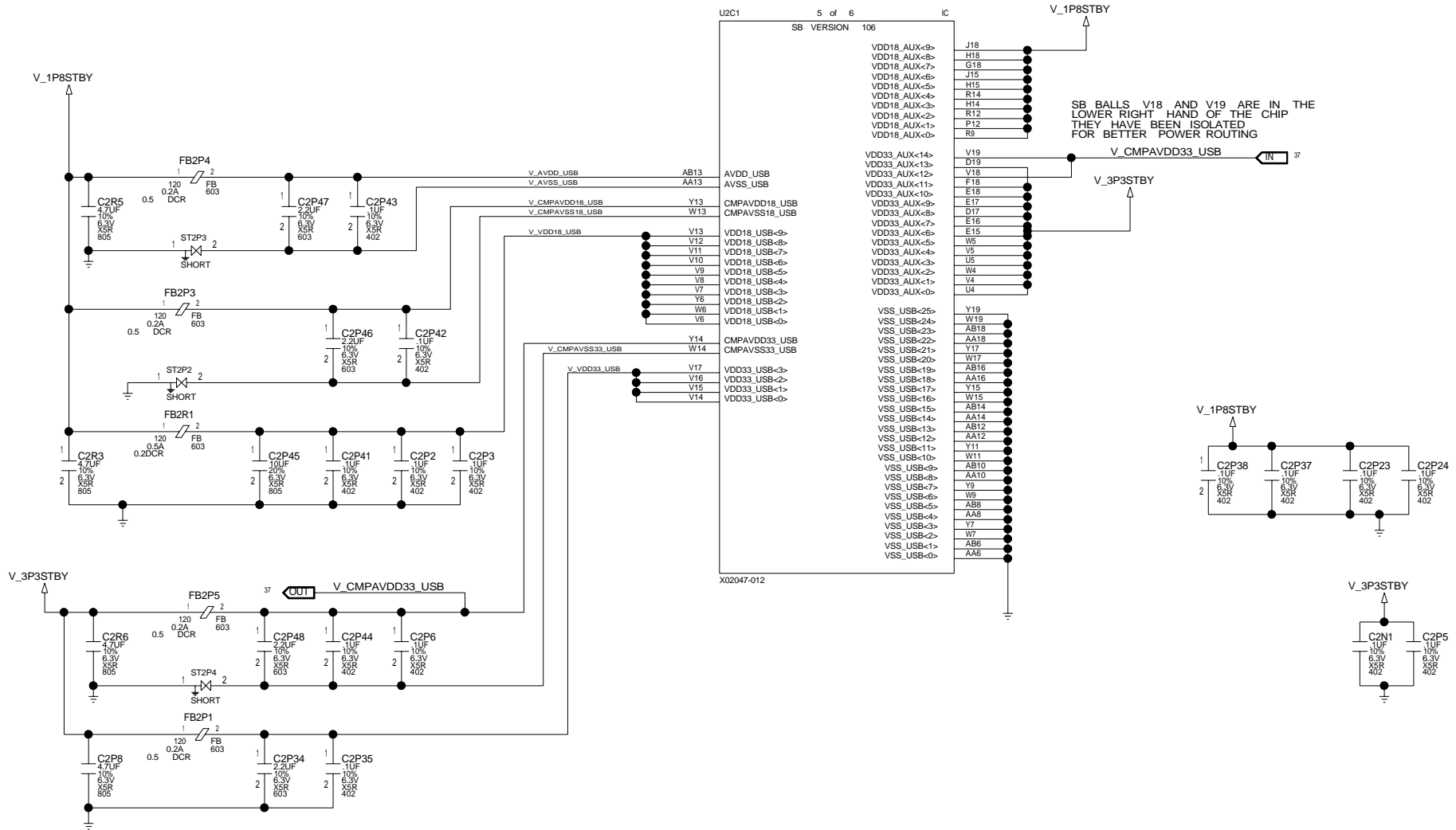

SB BALLS V18 AND V19 ARE IN THE LOWER RIGHT HAND OF THE CHIP THEY HAVE BEEN ISOLATED FOR BETTER POWER ROUTING

[PAGE_TITLE=SB, STANDBY POWER + DECOUPLING]

DRAWING TONASKET_FAB_A Thu Jan 29 11:47:23 2009

MICROSOFT CONFIDENTIAL	PROJECT NAME H09517	PAGE 37/83	REV A
------------------------	---------------------	------------	-------

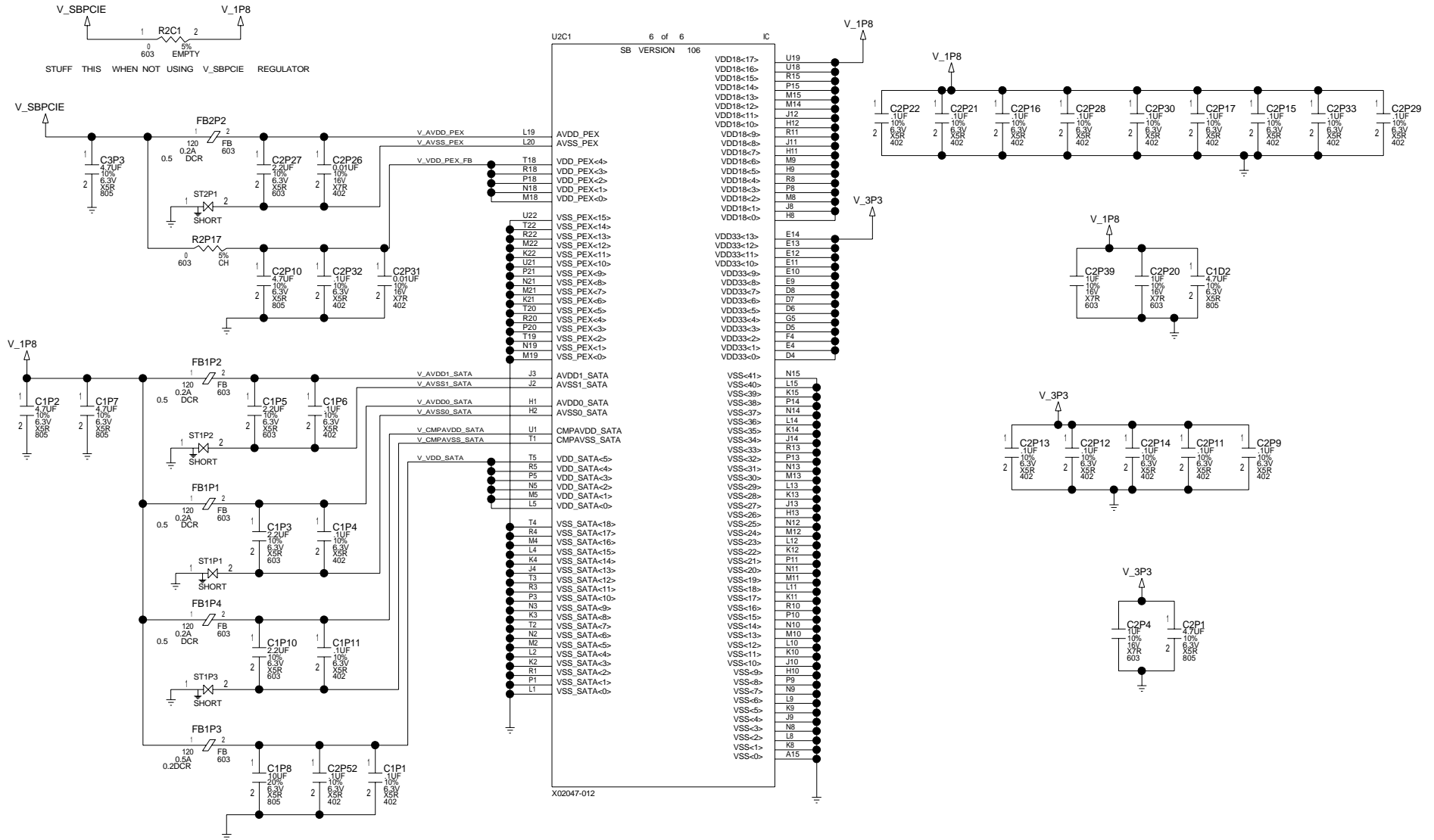

[PAGE_TITLE=SB, MAIN POWER + DECOUPLING]

DRAWING
TONASKET_FAB_A
Thu Jan 29 11:47:25

2009

MICROSOFT
CONFIDENTIAL

PROJECT NAME
H09517

PAGE
38/83

REV
A

BDCM PHY

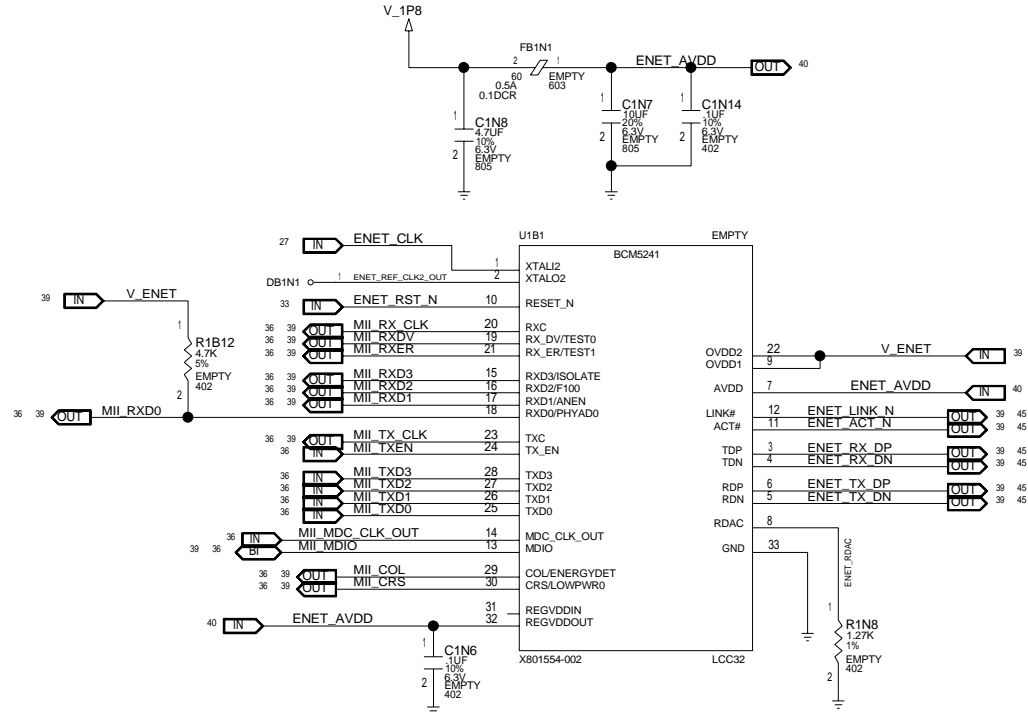

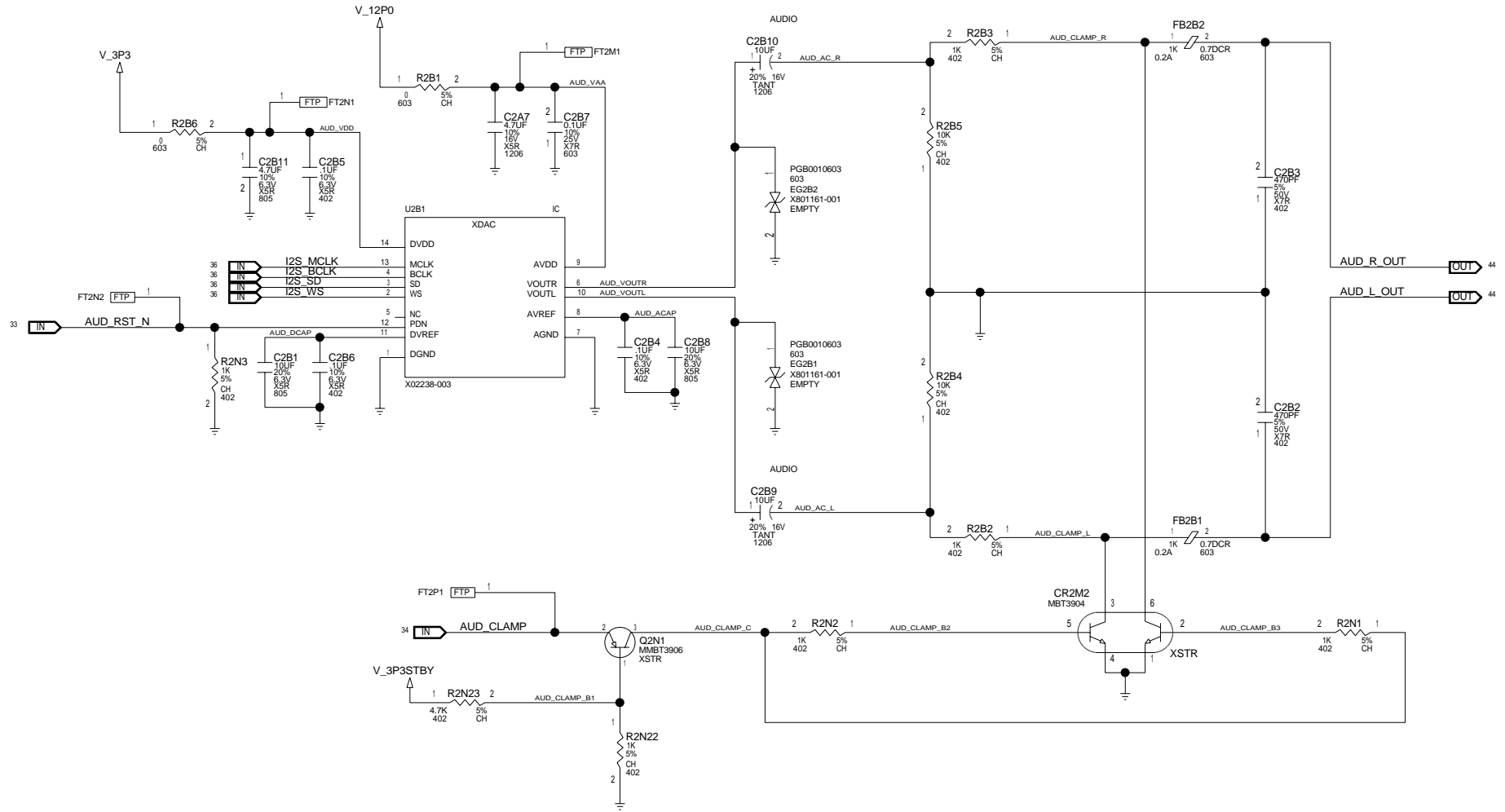

[PAGE_TITLE=SB OUT, AUDIO]

DRAWING
TONASKET_FAB_A
Thu Jan 29 11:47:27 2009

MICROSOFT CONFIDENTIAL	PROJECT NAME H09517	PAGE 41/83	REV A
---------------------------	------------------------	---------------	----------

XSB_SOUTHBRIDGE		
FLSH_DATA0		
FLSH_DATA1	0	1
0	8MB	16MB
1	32MB	64MB

N: RETAIL=16MB
N: XDK=64MB

PSB_SOUTHBRIDGE		
FLASH CONFIGURATION		
FLSH_DATA[1:0]		
0X0	0.5KB, 16KB	BLOCKS, 16MB
0X1	0.5KB, 16KB	BLOCKS, 16MB
0X2	2KB, 128KB	BLOCKS, VARIOUS SIZES
0X3	4KB, 256KB	BLOCKS, VARIOUS SIZES

RETAIL
XDK

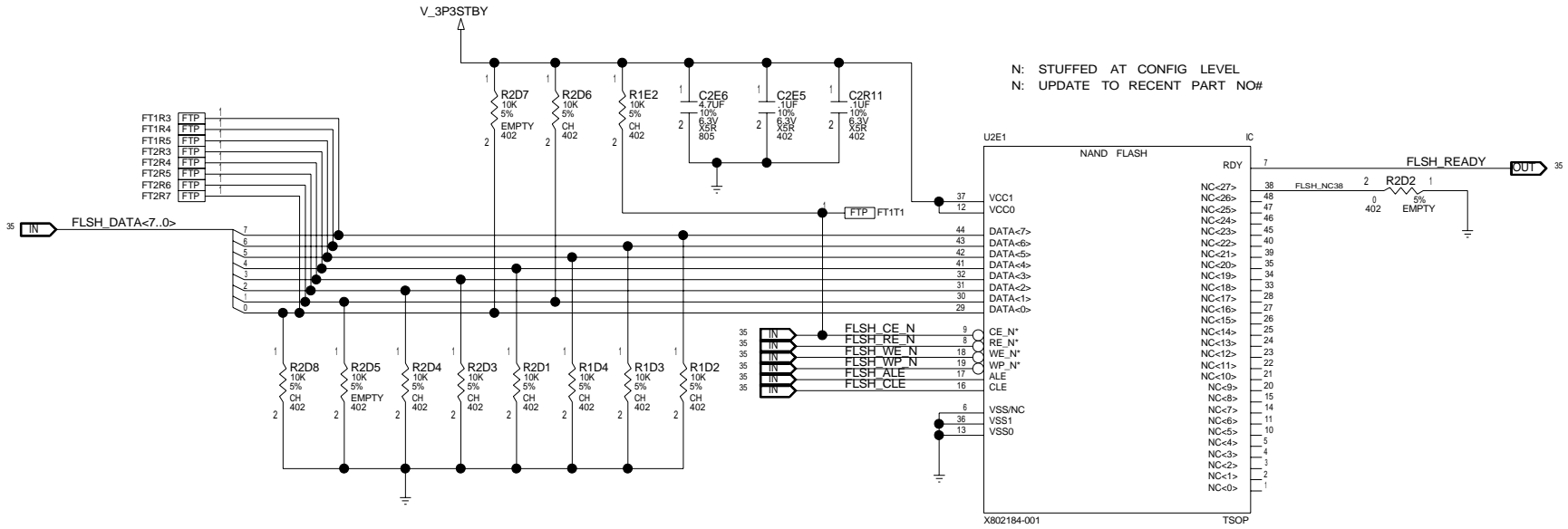

[PAGE_TITLE=SB OUT, FLASH]

DRAWING
TONASKET_FAB_A
Thu Jan 29 11:47:28 2009

MICROSOFT CONFIDENTIAL	PROJECT NAME H09517	PAGE 42/83	REV A
---------------------------	------------------------	---------------	----------

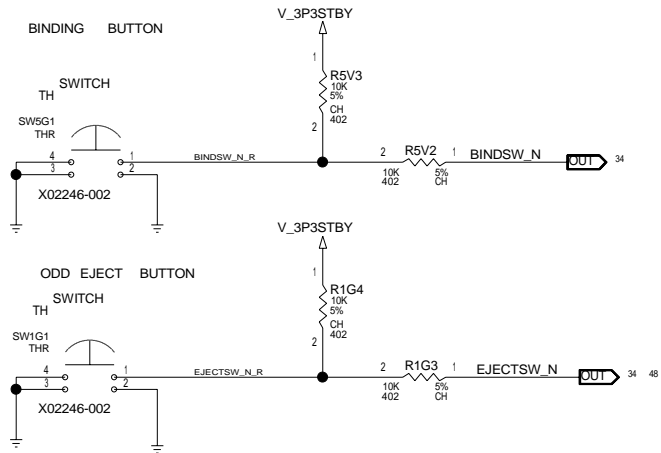

N: X800550-003 HOLDS ALL THREE TILT SWITCHES
 TMEC ONLY HAS 3 PINS WHICH REQUIRES A DIFFERENT
 UNIQUE PART NUMBER TO HOLD THE SYMBOL NAME
 N: BOM MUST CALL OUT X800550-003 WITH QTY 1 AND
 LIST ALL THREE REF DES. FACTORY CHOOSES FROM THERE

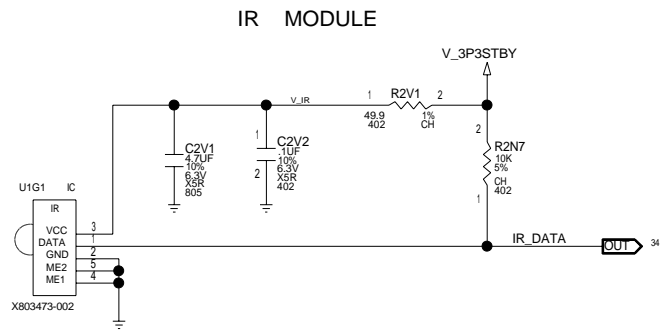
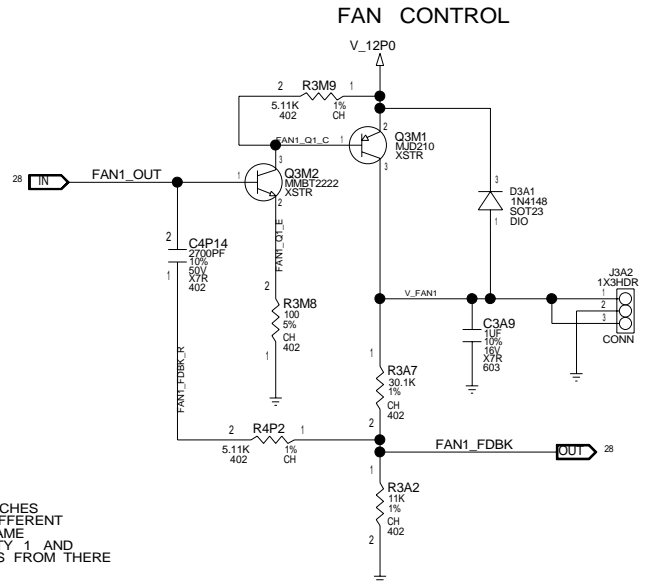
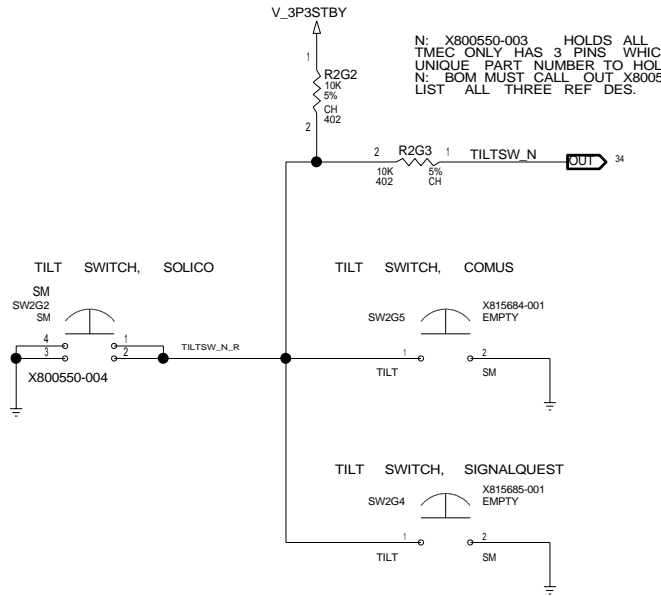

[PAGE_TITLE=CONN, FAN + INFRARED + SWITCHES]

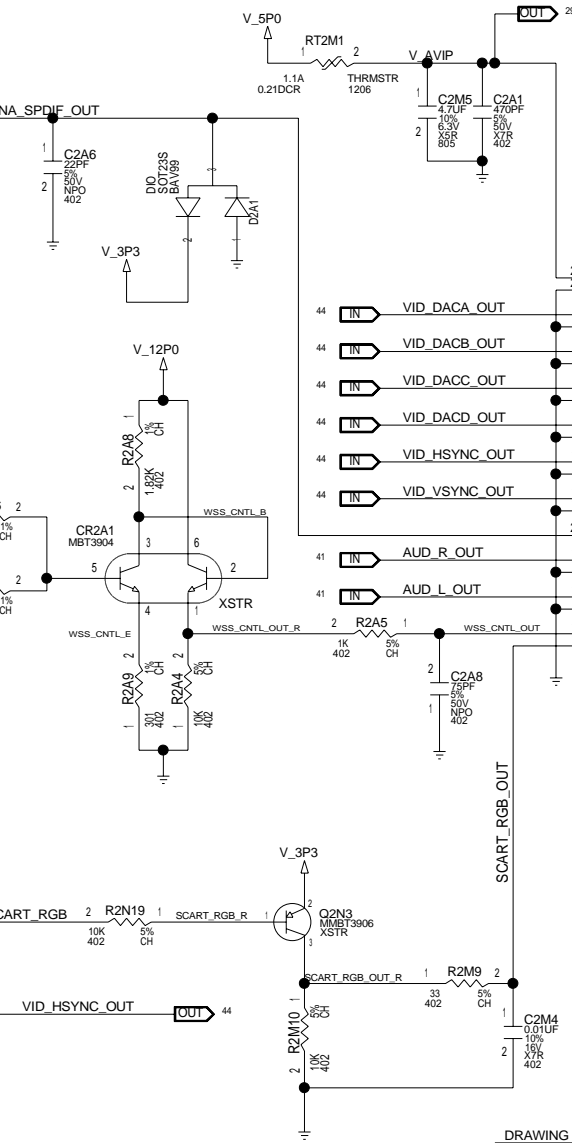
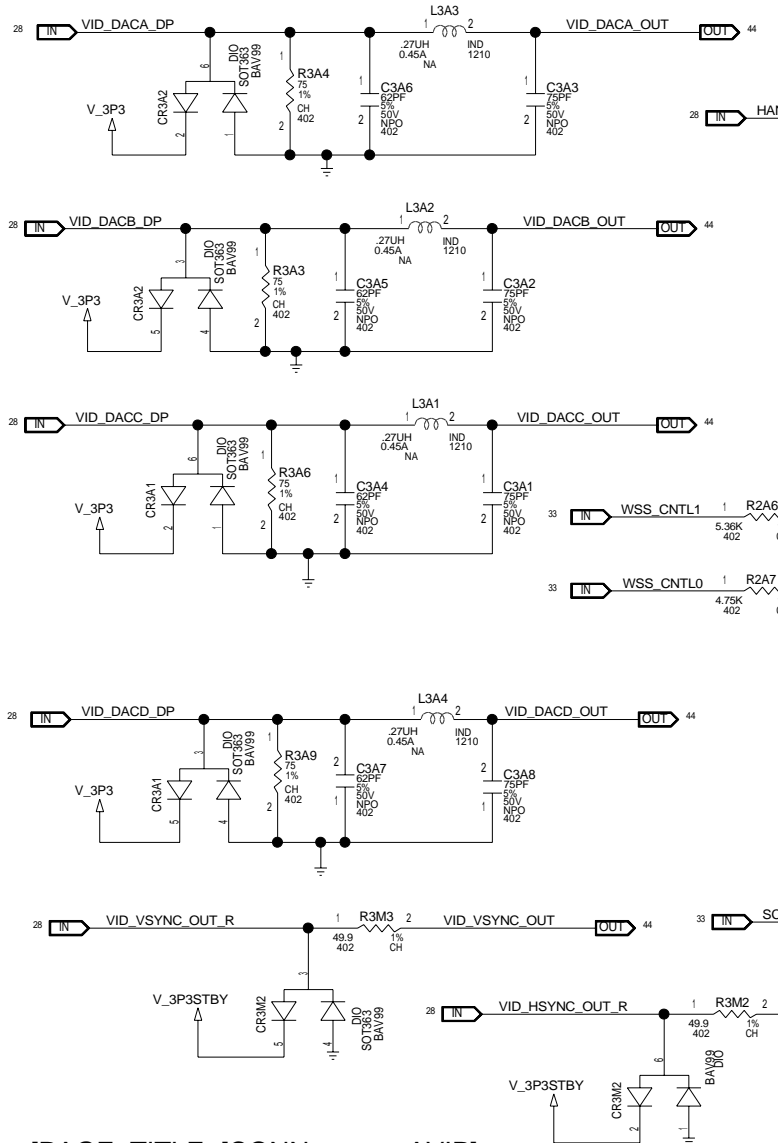

	DAC	STANDARD	ADVANCED	SDTV	HDTV	SCART	VGA
A	N/A	Y(LUMA)	Y	Y	G	G	
B	N/A	C(CHROMA)	PR	PR	R	R	
C	N/A	N/A	PB	PB	B	B	
D	CVBS(COMP)	CVBS(COMP)	CVBS	N/A	CVBS	CVBS	

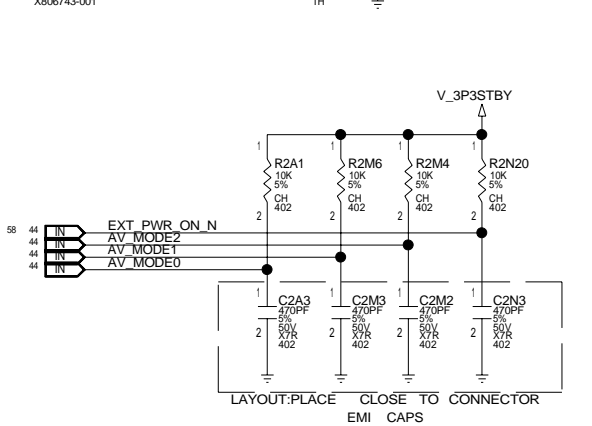
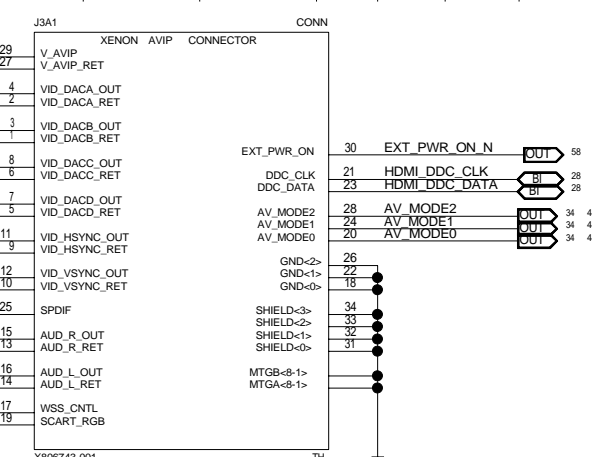

[PAGE_TITLE=[CONN, AVIP]

DRAWING JASPER_FABA Thu Jan 29 11:47:33 2009

MICROSOFT CONFIDENTIAL	PROJECT NAME H09517	PAGE 44/83	REV A
------------------------	---------------------	------------	-------

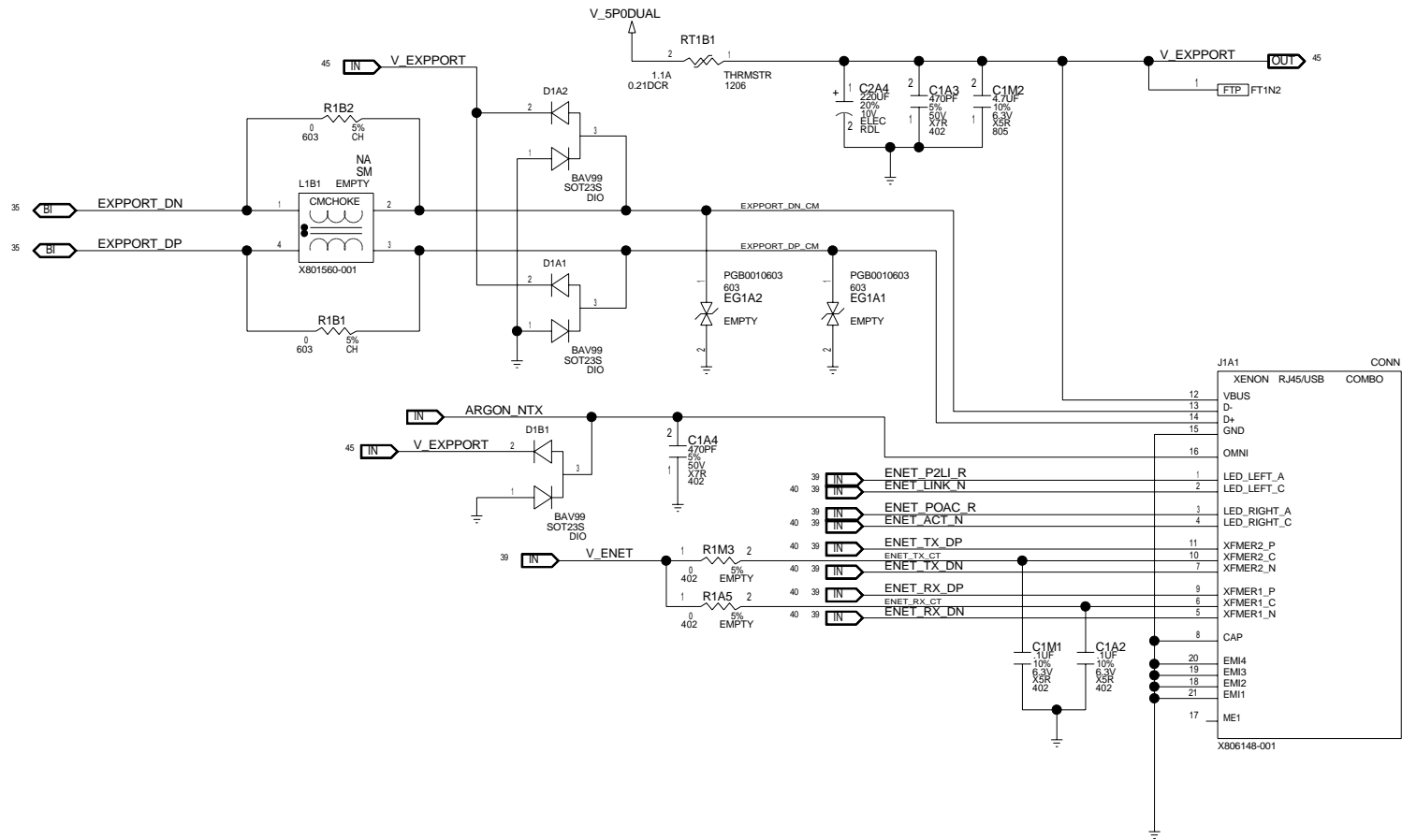

[PAGE_TITLE=CONN, RJ45 + USB COMBO]

DRAWING
TONASKET_FAB A
Thu Jan 29 11:47:34 2009

MICROSOFT CONFIDENTIAL	PROJECT NAME H09517	PAGE 45/83	REV A
---------------------------	------------------------	---------------	----------

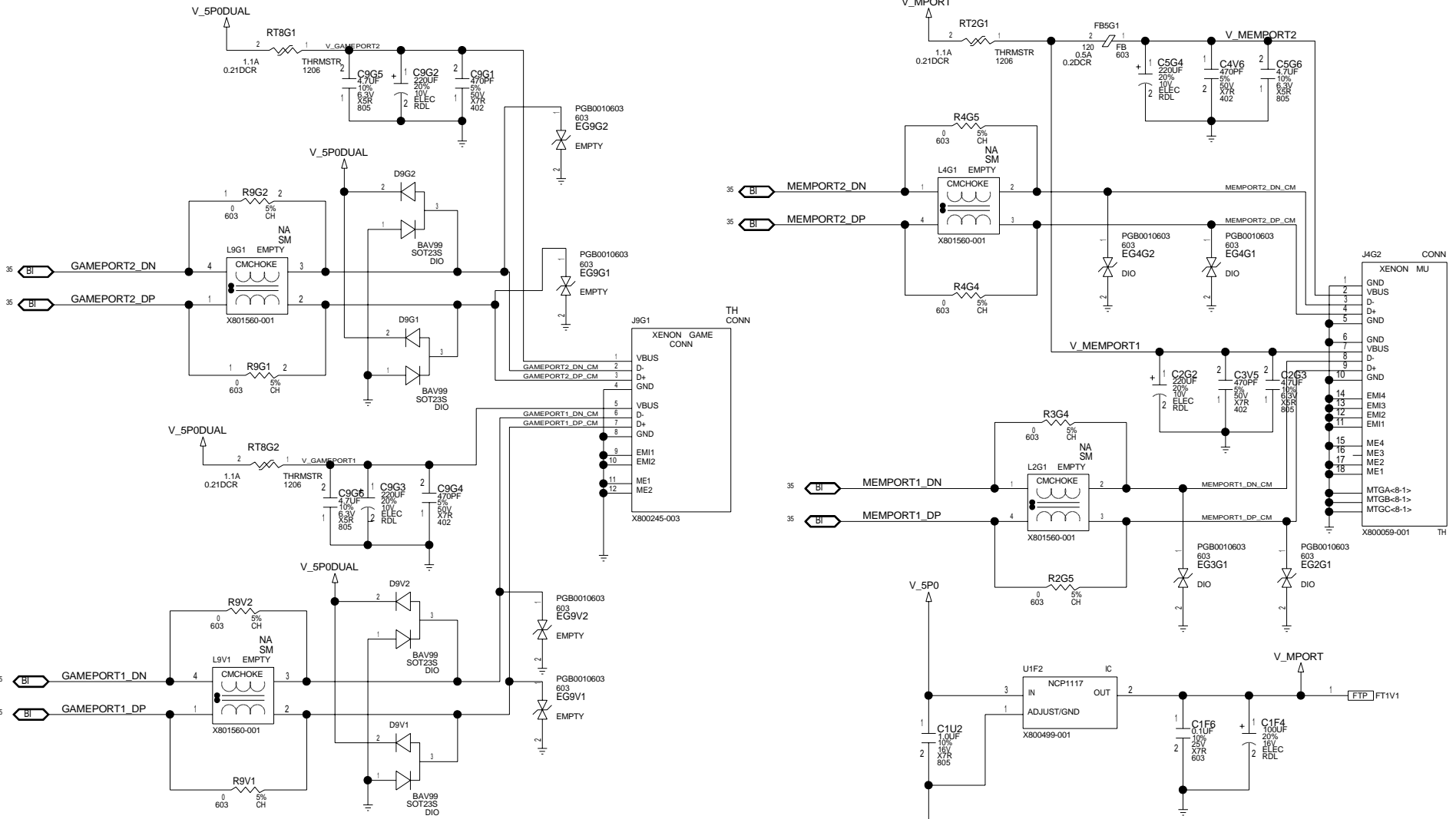

[PAGE_TITLE=CONN, MEMORY PORTS + GAME PORTS]

DRAWING
TONASKET_FAB_A
Thu Jan 29 11:47:35 2009

MICROSOFT CONFIDENTIAL	PROJECT NAME H09517	PAGE 46/83	REV A
---------------------------	------------------------	---------------	----------

XDK BOARD MAPPING

DEBUG BOARD MAPPING

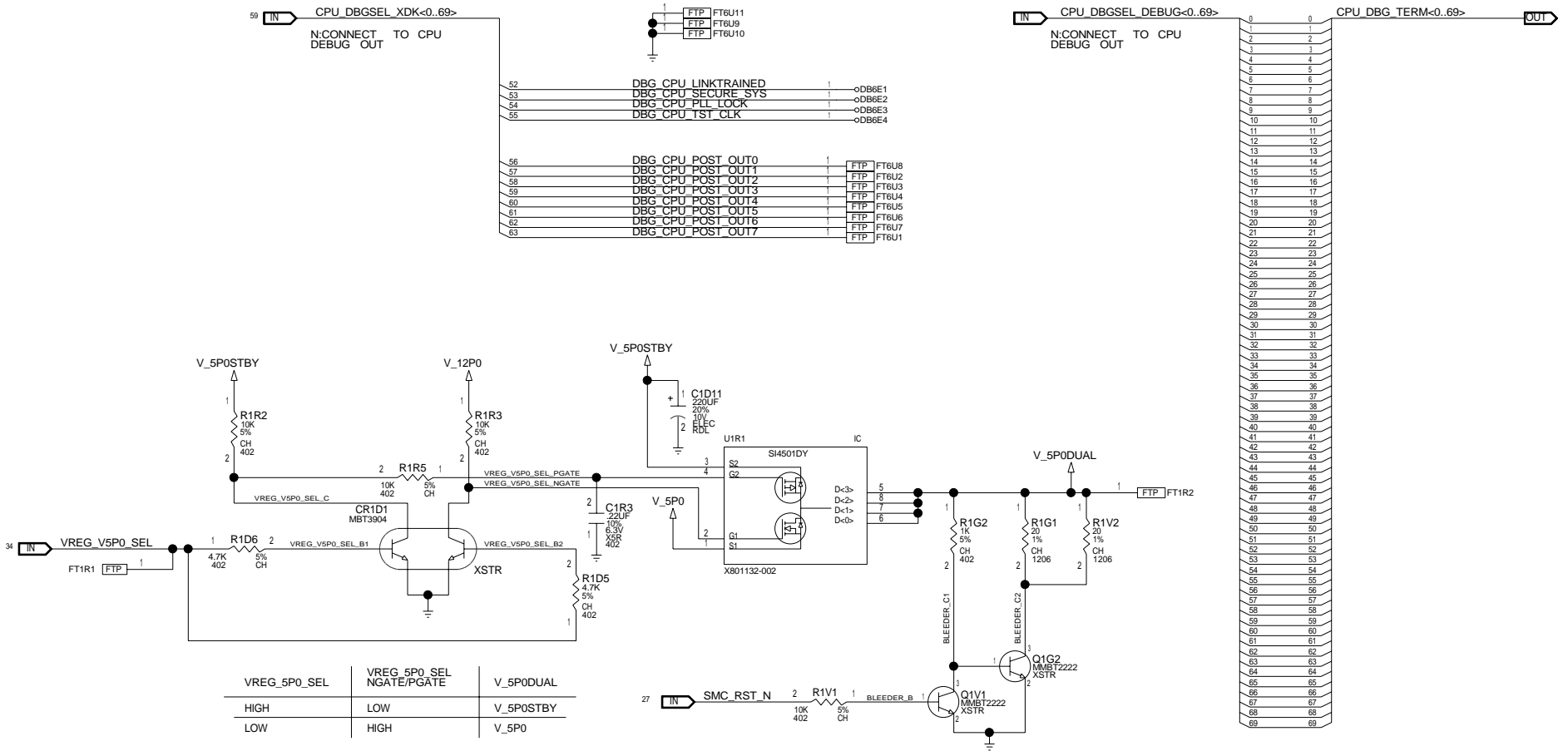

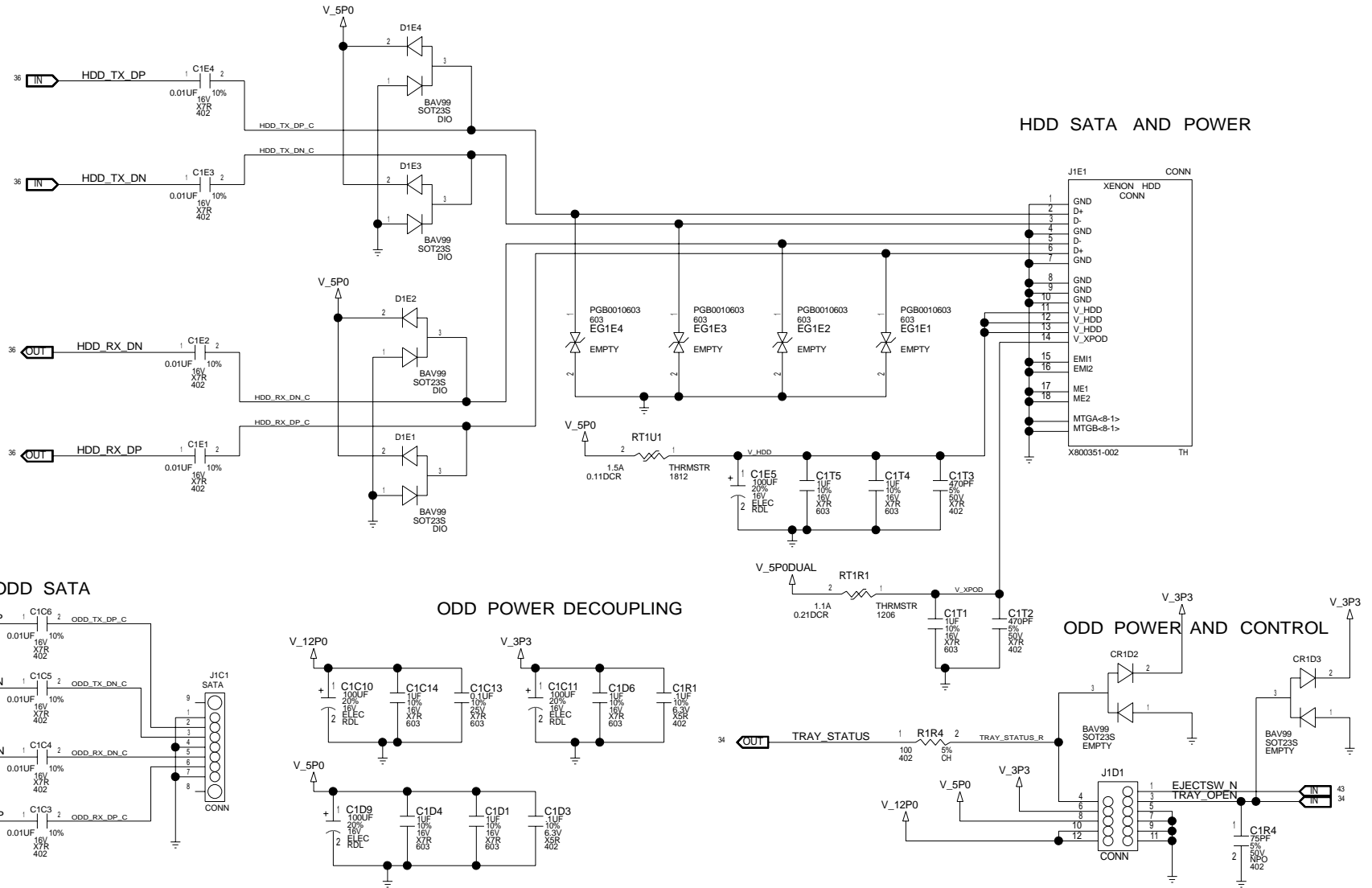

[PAGE_TITLE=CONN, ODD + HDD]

DRAWING
TONASKET_FAB_A
Thu Jan 29 11:47:53 2009

MICROSOFT CONFIDENTIAL	PROJECT NAME H09517	PAGE 48/83	REV A
---------------------------	------------------------	---------------	----------

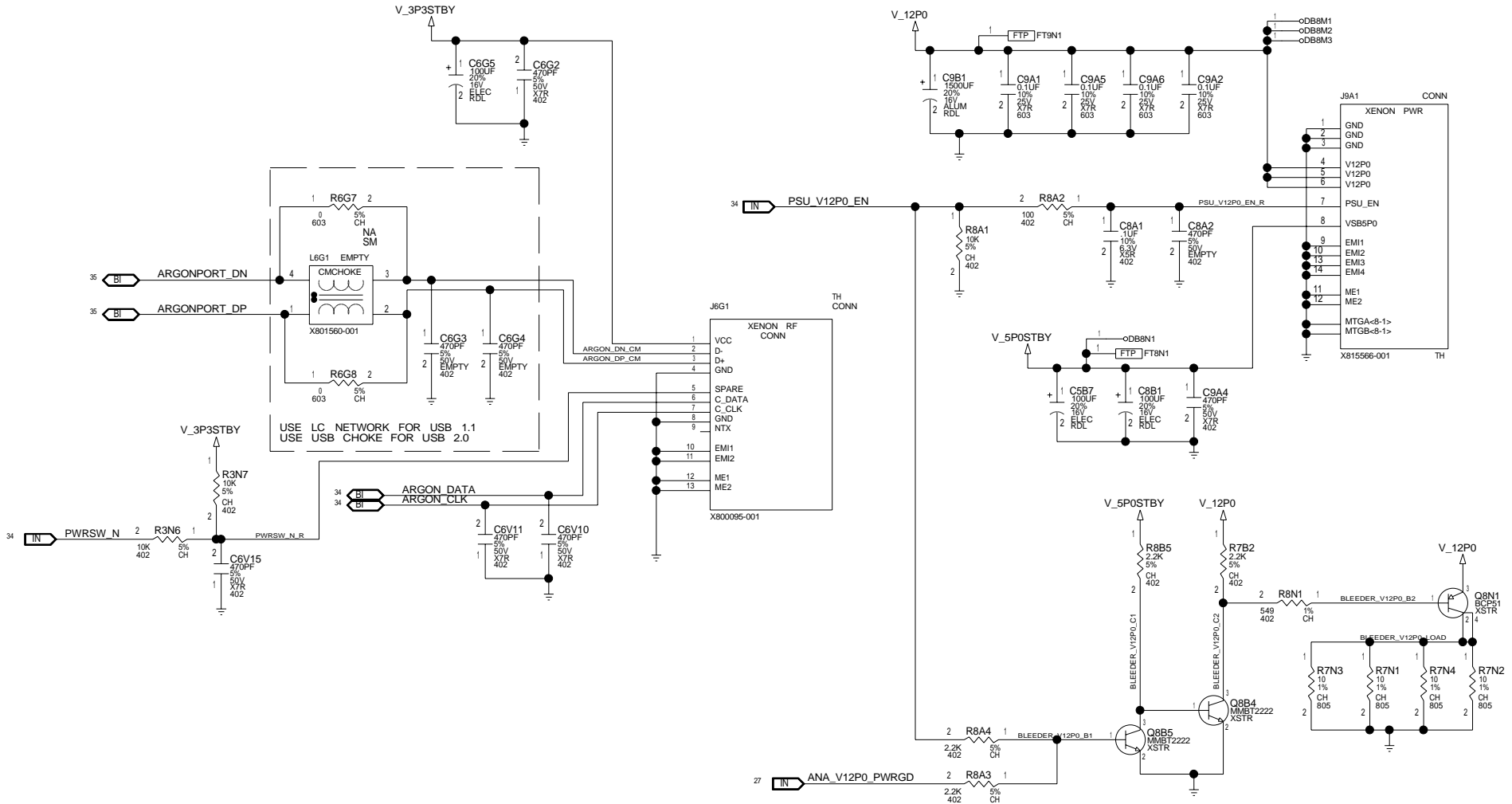

[PAGE_TITLE=CONN, ARGON + POWER SUPPLY]

DRAWING
TONASKET_FAB_A
Thu Jan 29 11:47:36 2009

MICROSOFT CONFIDENTIAL	PROJECT NAME H09517	PAGE 49/83	REV A
---------------------------	------------------------	---------------	----------

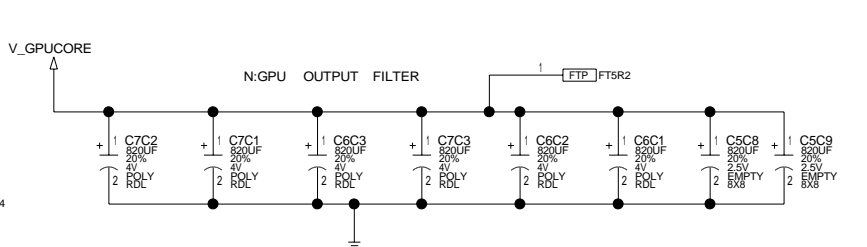
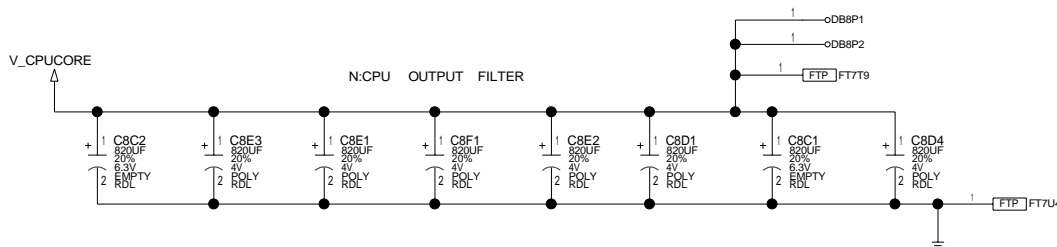
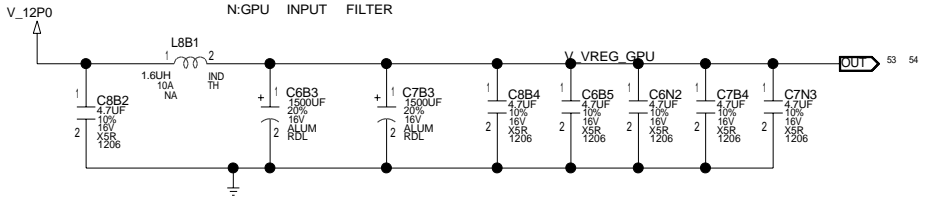
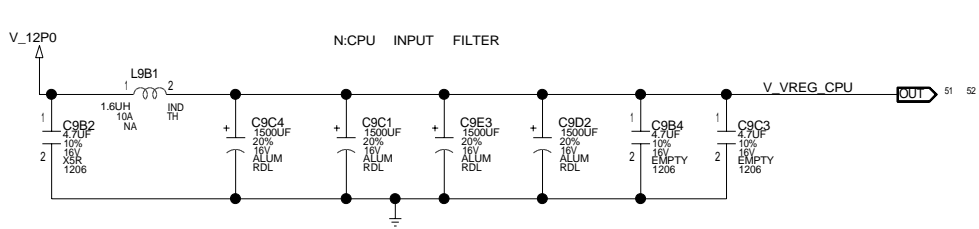
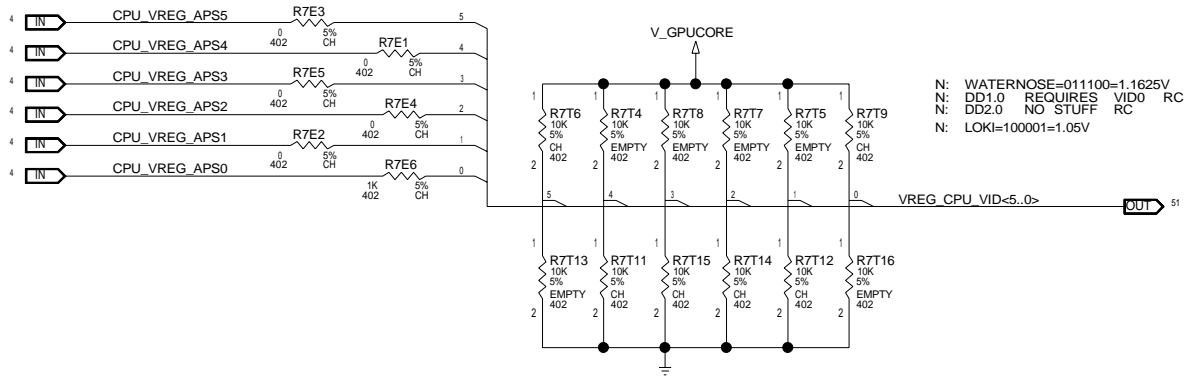

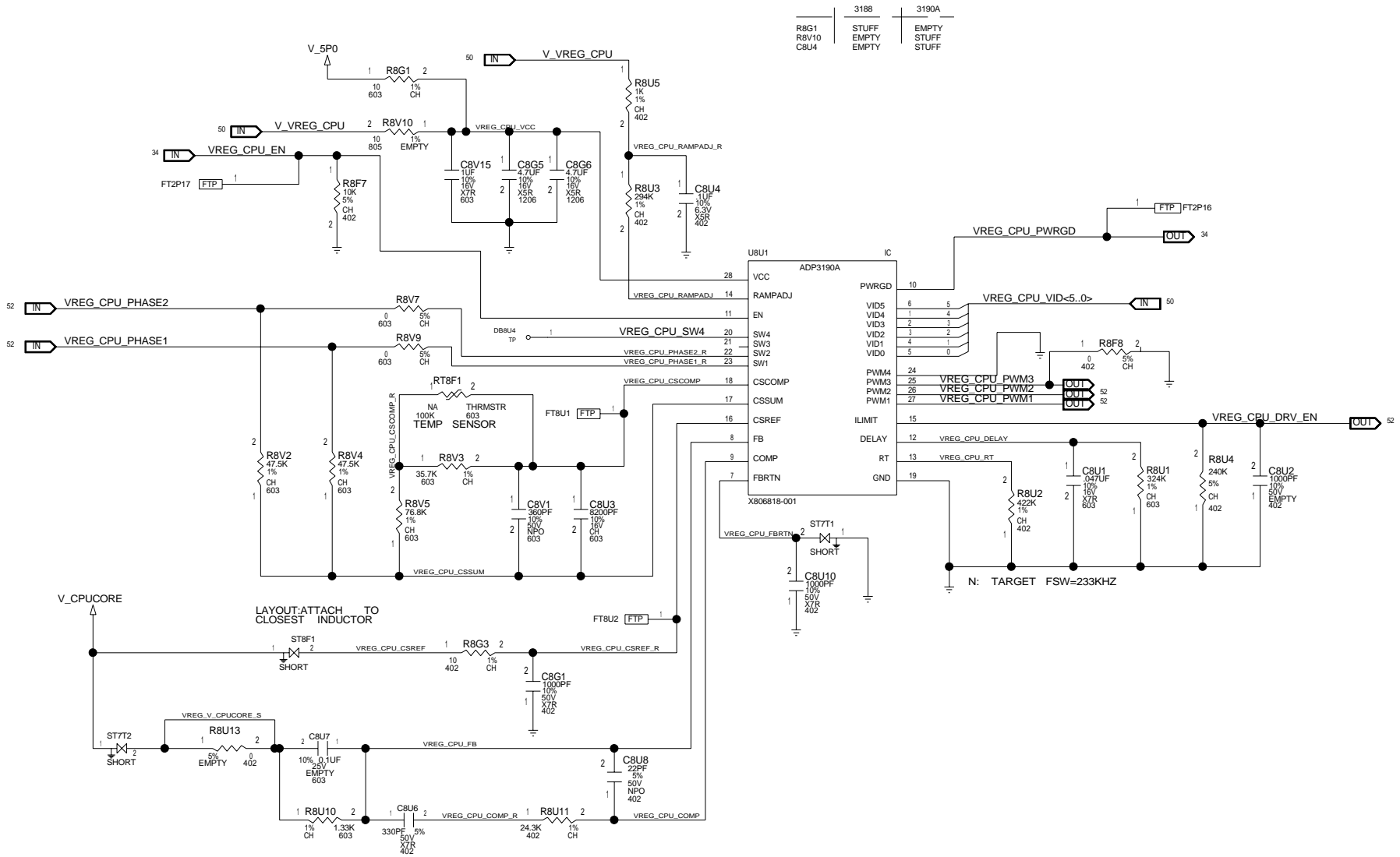

[PAGE_TITLE=VREGS, CPU CONTROLLER]

DRAWING
TONASKET_FAB_A
Thu Jan 29 11:47:39 2009

MICROSOFT CONFIDENTIAL	PROJECT NAME H09517	PAGE 51/83	REV A
---------------------------	------------------------	---------------	----------

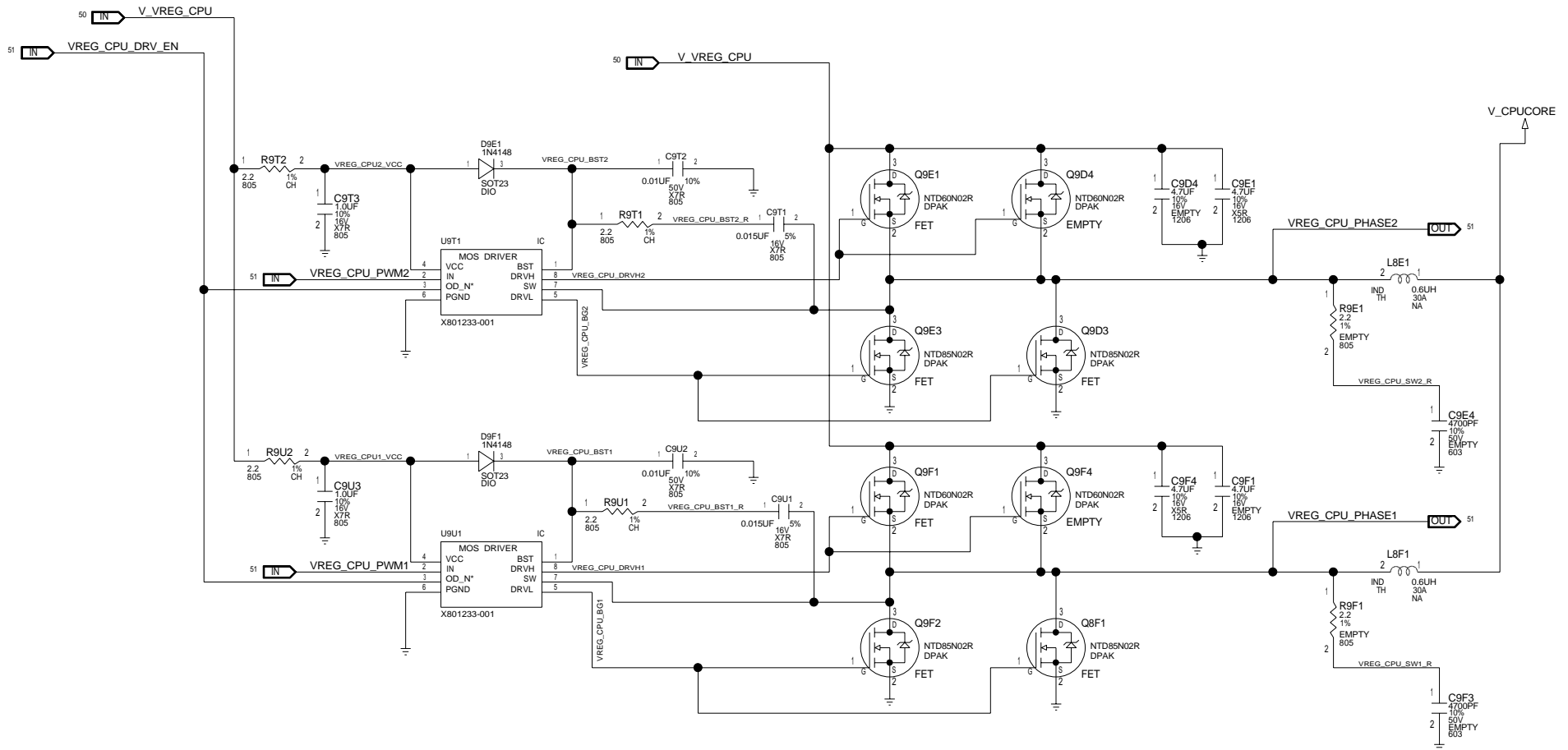

[PAGE_TITLE=VREGS, CPU OUTPUT PHASE 1,2]

DRAWING
TONASKET_FAB_A
Thu Jan 29 11:47:40 2009

MICROSOFT CONFIDENTIAL	PROJECT H09517	NAME	PAGE 52/83	REV A
---------------------------	-------------------	------	---------------	----------

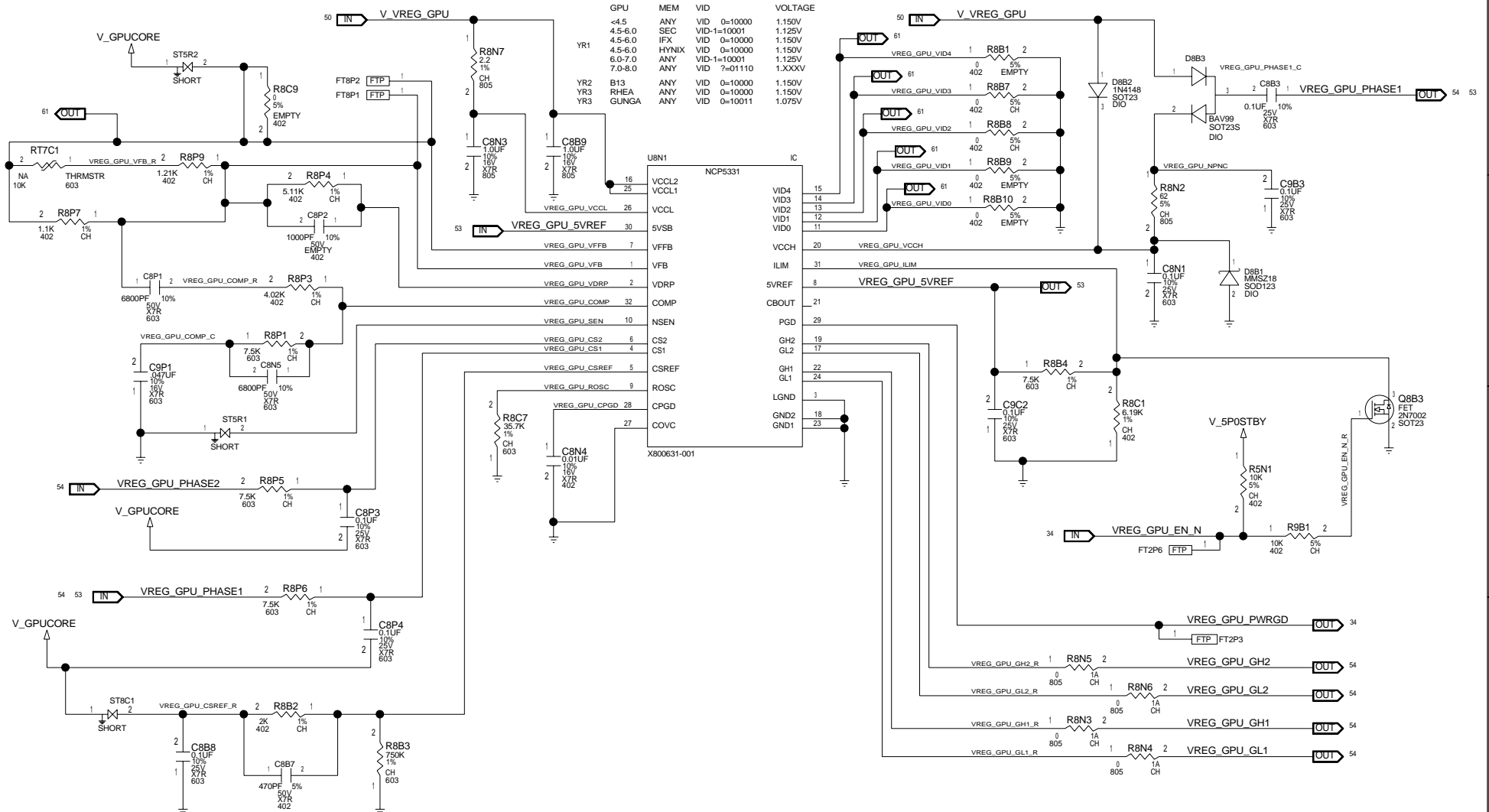

[PAGE_TITLE=VREGS, GPU CONTROLLER]

DRAWING
TONASKET_FAB_A
Thu Jan 29 11:47:42

2009

MICROSOFT CONFIDENTIAL	PROJECT NAME H09517	PAGE 53/83	REV A
---------------------------	------------------------	---------------	----------

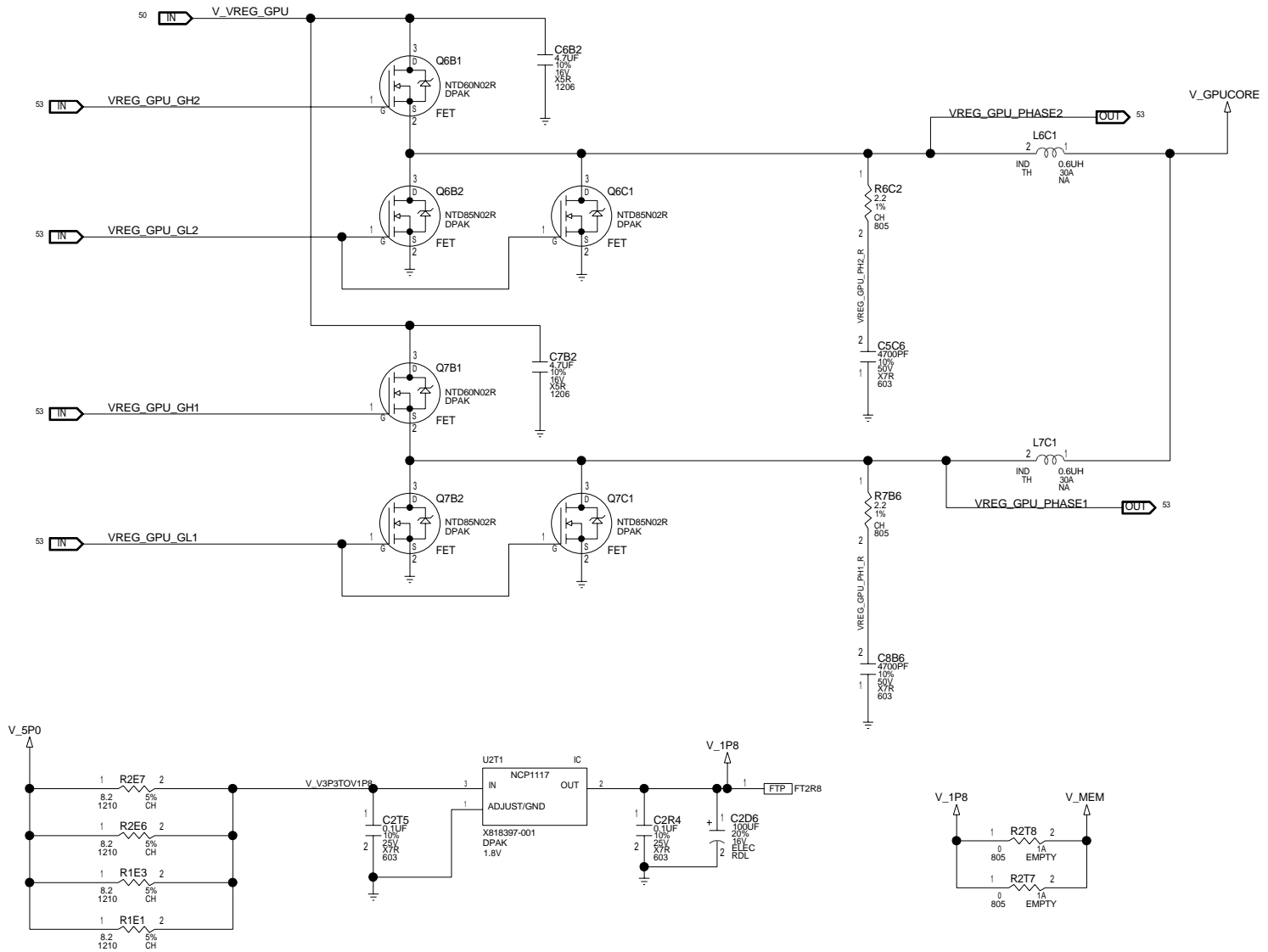

[PAGE_TITLE=VREGS, GPU OUTPUT PHASE 1,2]

DRAWING
TONASKET_FAB_A
Thu Jan 29 11:47:43 2009

MICROSOFT CONFIDENTIAL	PROJECT NAME H09517	PAGE 54/83	REV A
---------------------------	------------------------	---------------	----------

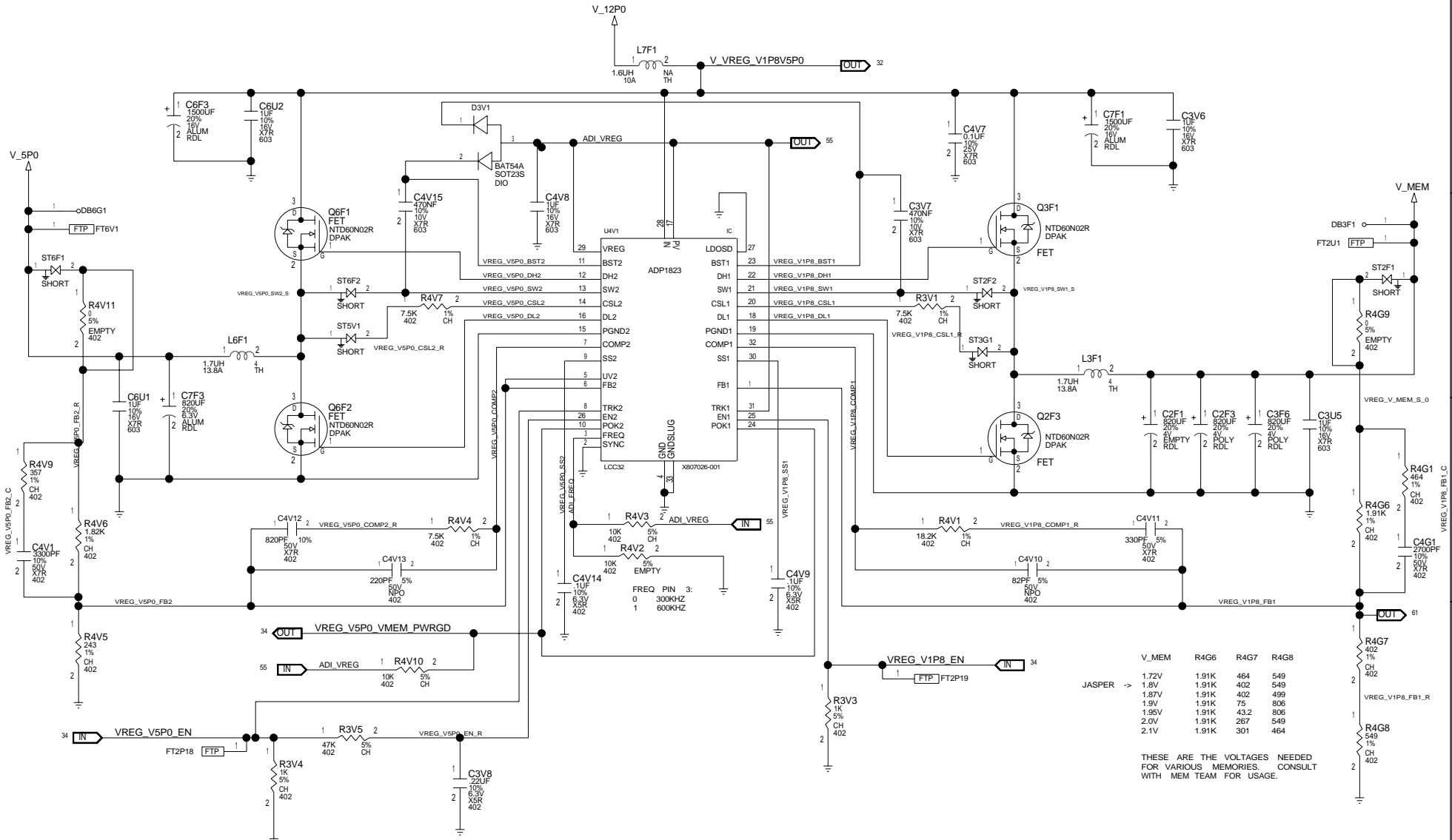

[PAGE_TITLE=VREGS, V1P8 AND V5P0]

DRAWING TONASKET_FAB_A Thu Jan 29 11:47:45 2009

MICROSOFT CONFIDENTIAL	PROJECT NAME H09517	PAGE 55/83	REV A
------------------------	---------------------	------------	-------

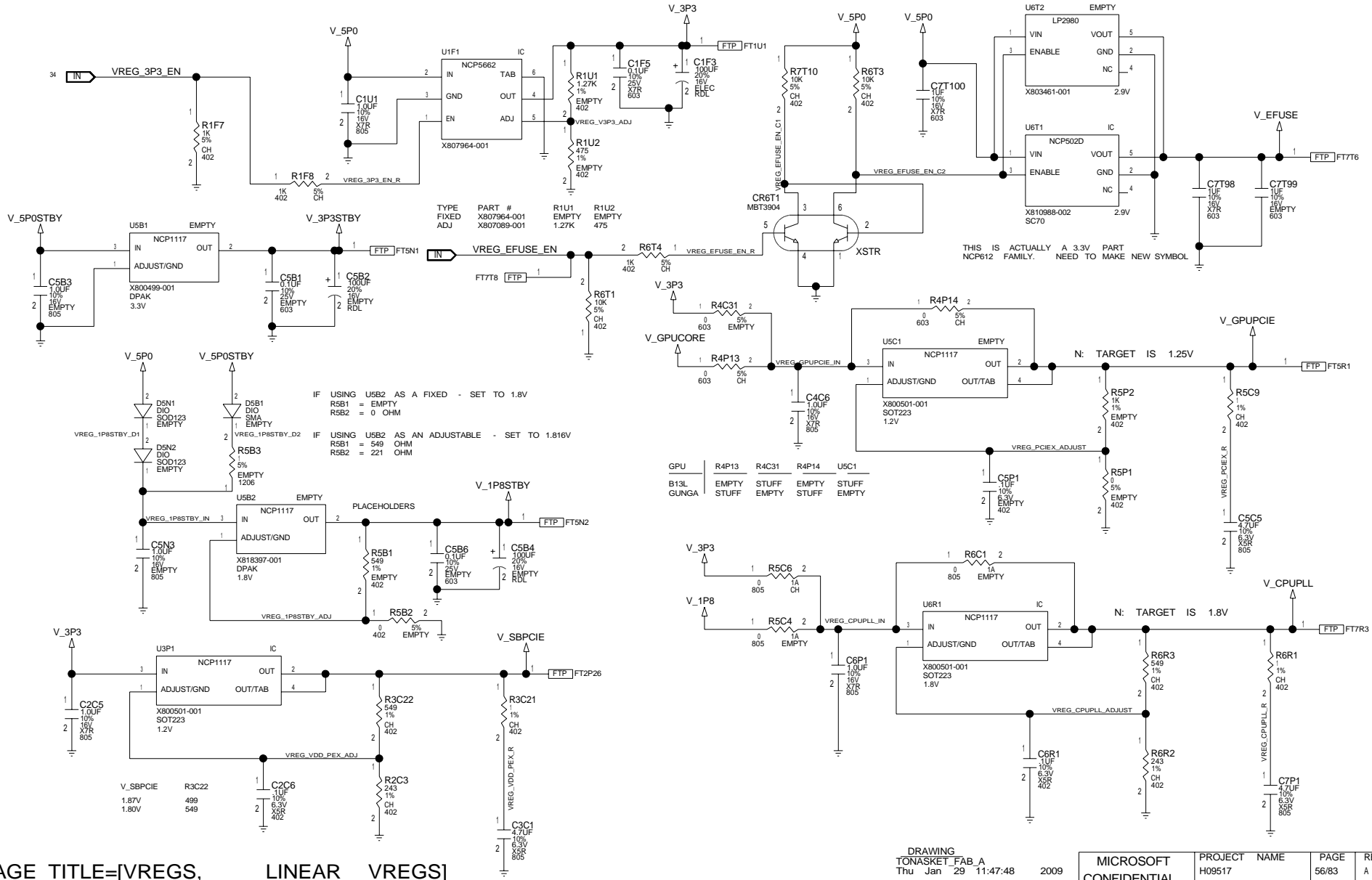

[PAGE_TITLE]=[VREGS, LINEAR VREGS]

VCS REGULATOR

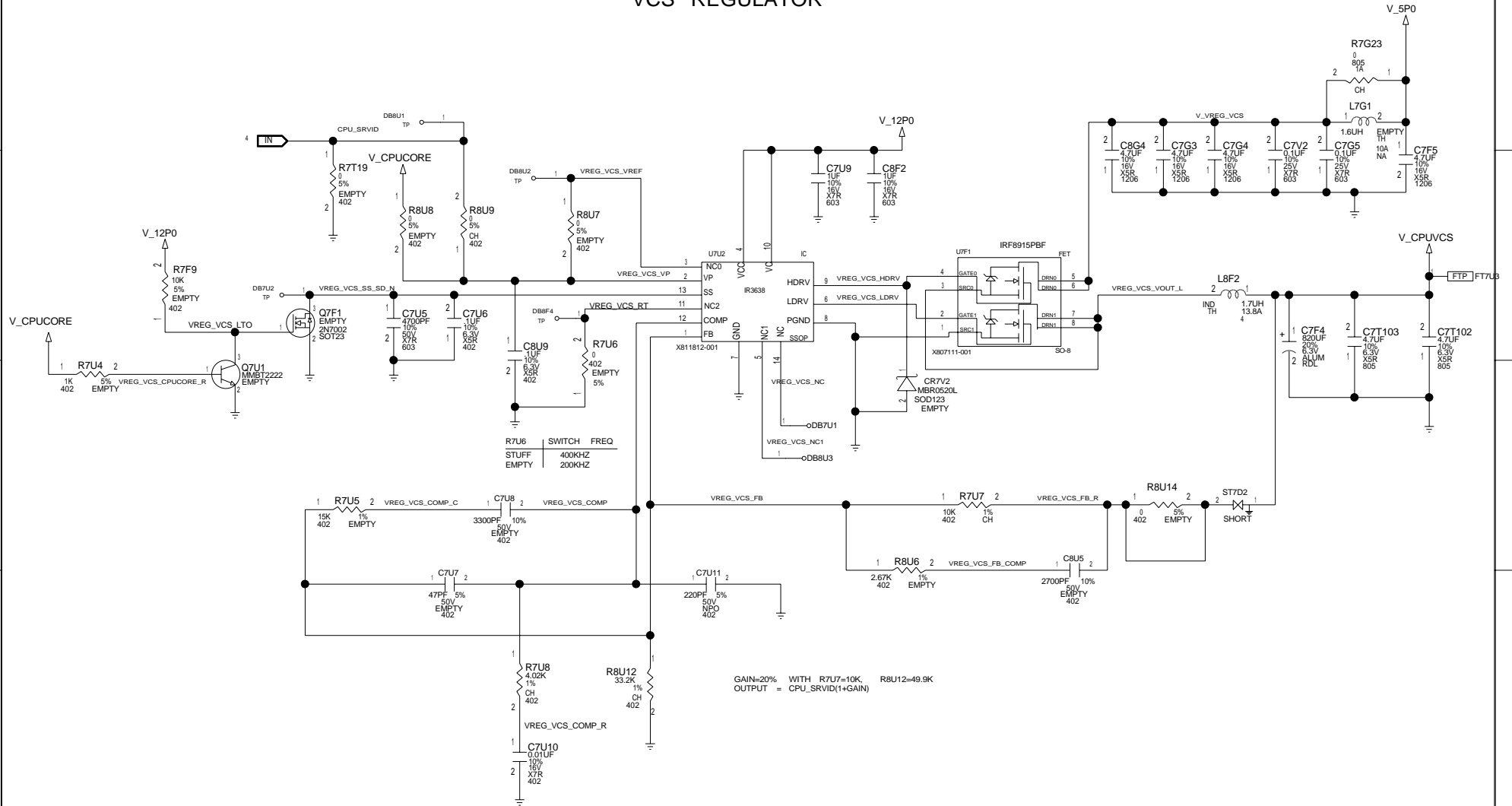

DRAWING
 TONASKET_FAB_A
 Thu Jan 29 11:47:51 2009

MICROSOFT CONFIDENTIAL	PROJECT NAME H09517	PAGE 57/83	REV A
---------------------------	------------------------	---------------	----------

XDK, DEBUG CONNECTORS

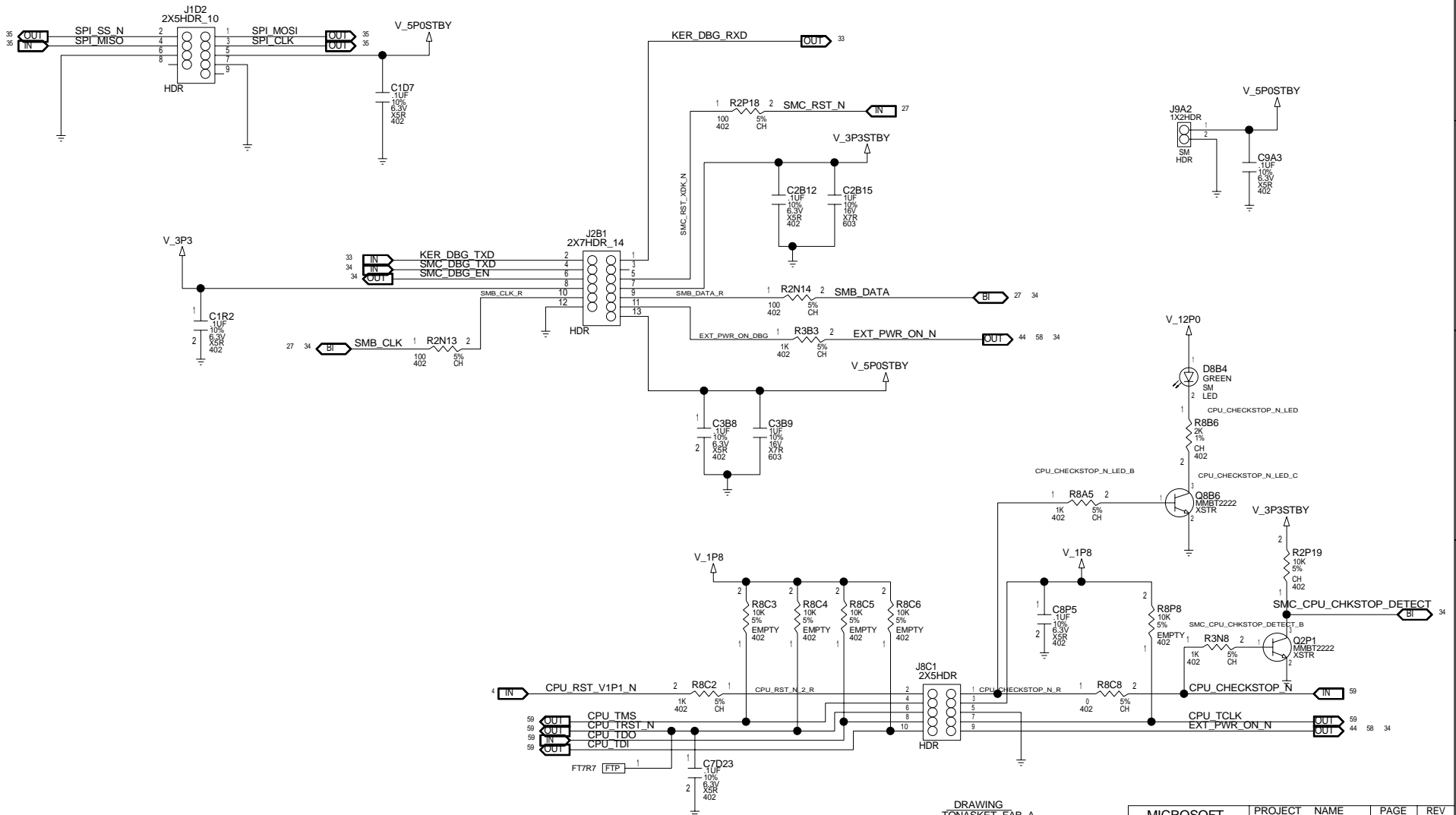

[PAGE_TITLE=XDK. DEBUG CONN]

DRAWING
TONASKET_FAB_A
Thu Jan 29 11:47:49 2009

MICROSOFT CONFIDENTIAL	PROJECT NAME H09517	PAGE 58/83	REV A
---------------------------	------------------------	---------------	----------

DEBUG BOARD, CPU + GPU DEBUG BREAKOUT

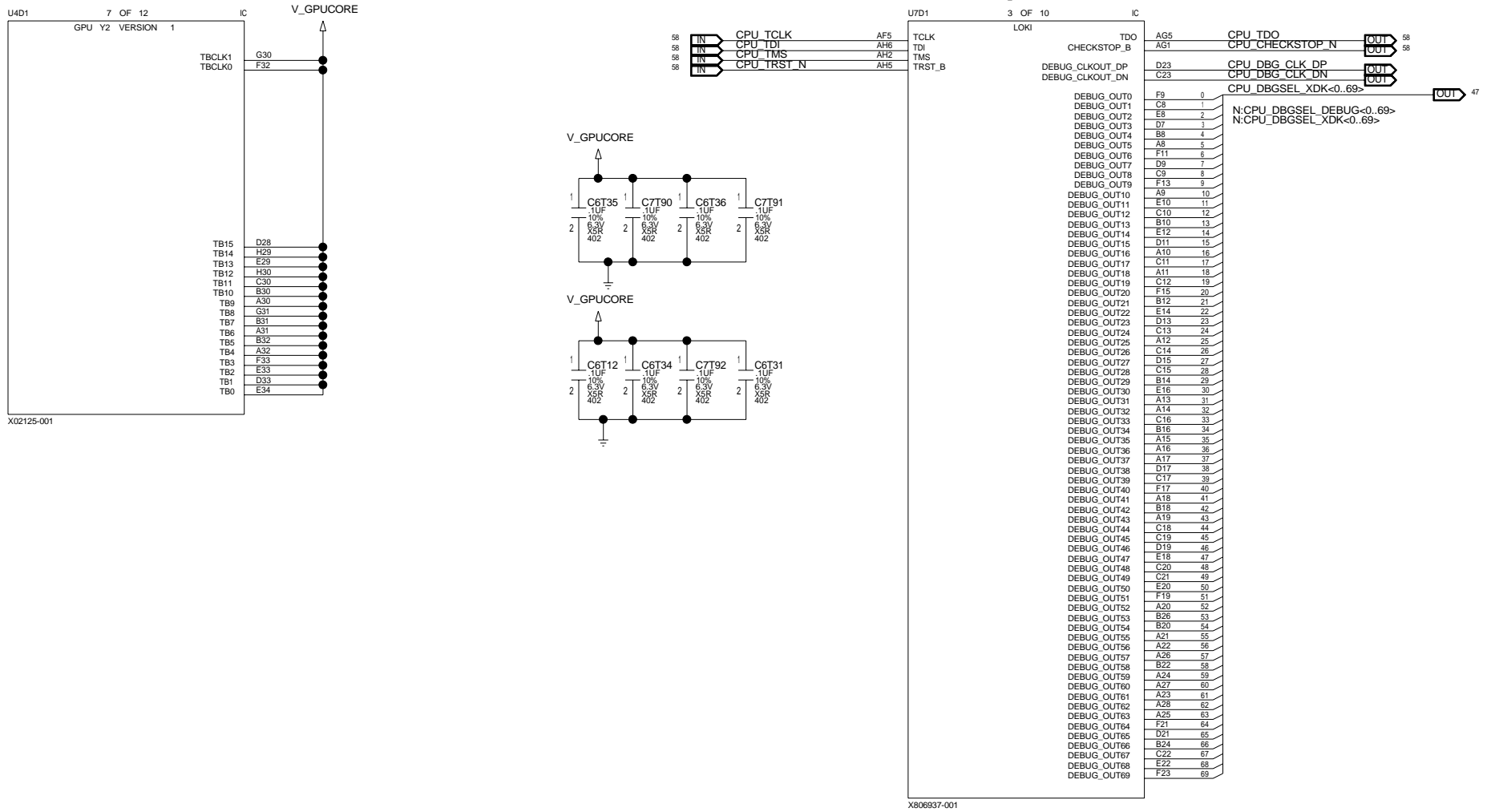

[PAGE_TITLE=DEBUG BOARD, CPU + GPU DEBUG BREAKOUT]

DRAWING
 JASPER_FABA
 Thu Jan 29 11:47:50 2009

MICROSOFT CONFIDENTIAL	PROJECT NAME H09517	PAGE 59/83	REV A
---------------------------	------------------------	---------------	----------

INTELLIGENT SERIAL NUMBER TARGET.



MIDDLE PCB MOUNTING HOLES

EAST PCB MOUNTING HOLES

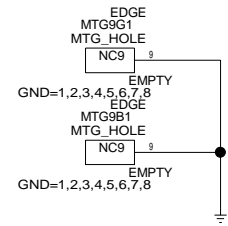
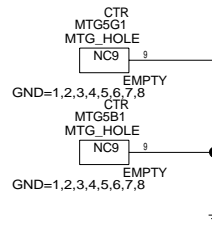
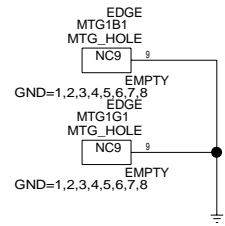

HEAT SINK MOUNTING HOLES

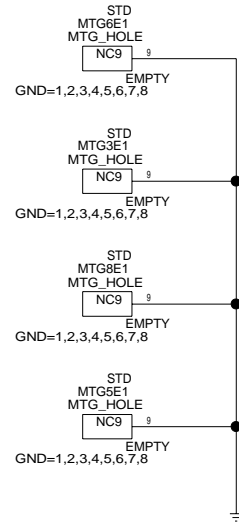
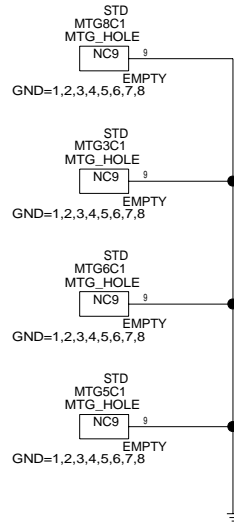

GPU VID BOARD

60 OHM COUPONS (TOP & BOTTOM)

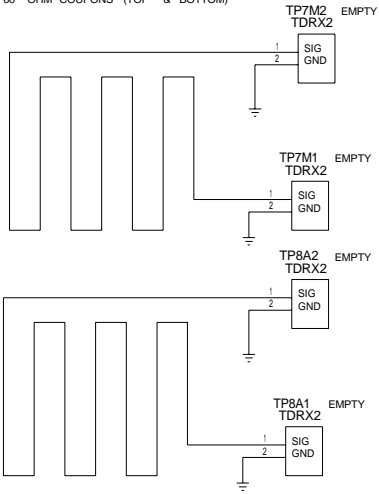

THESE CONNECTORS ARE EMPTY BY DEFAULT
THEY ARE ONLY STUFFED WHEN VIPER IS REQUIRED

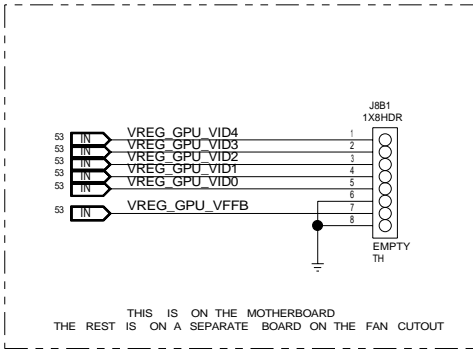

THIS IS ON THE MOTHERBOARD
THE REST IS ON A SEPARATE BOARD ON THE FAN CUTOUT

50 OHM COUPONS (TOP)

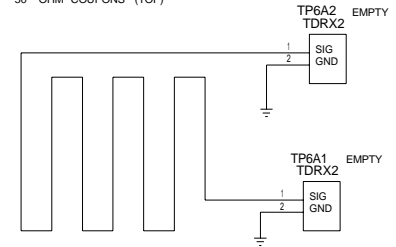

90 OHM COUPONS (TOP)

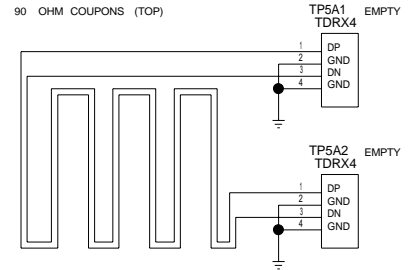

100 OHM COUPONS (TOP & BOTTOM)

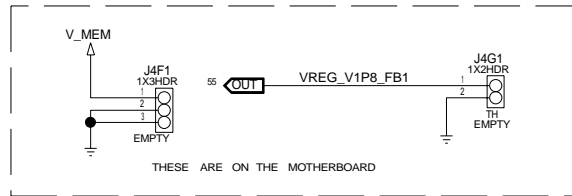
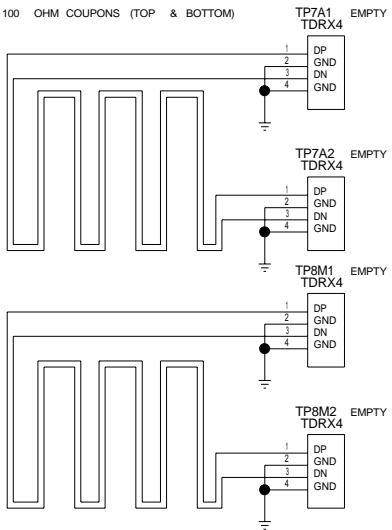

THESE ARE ON THE MOTHERBOARD

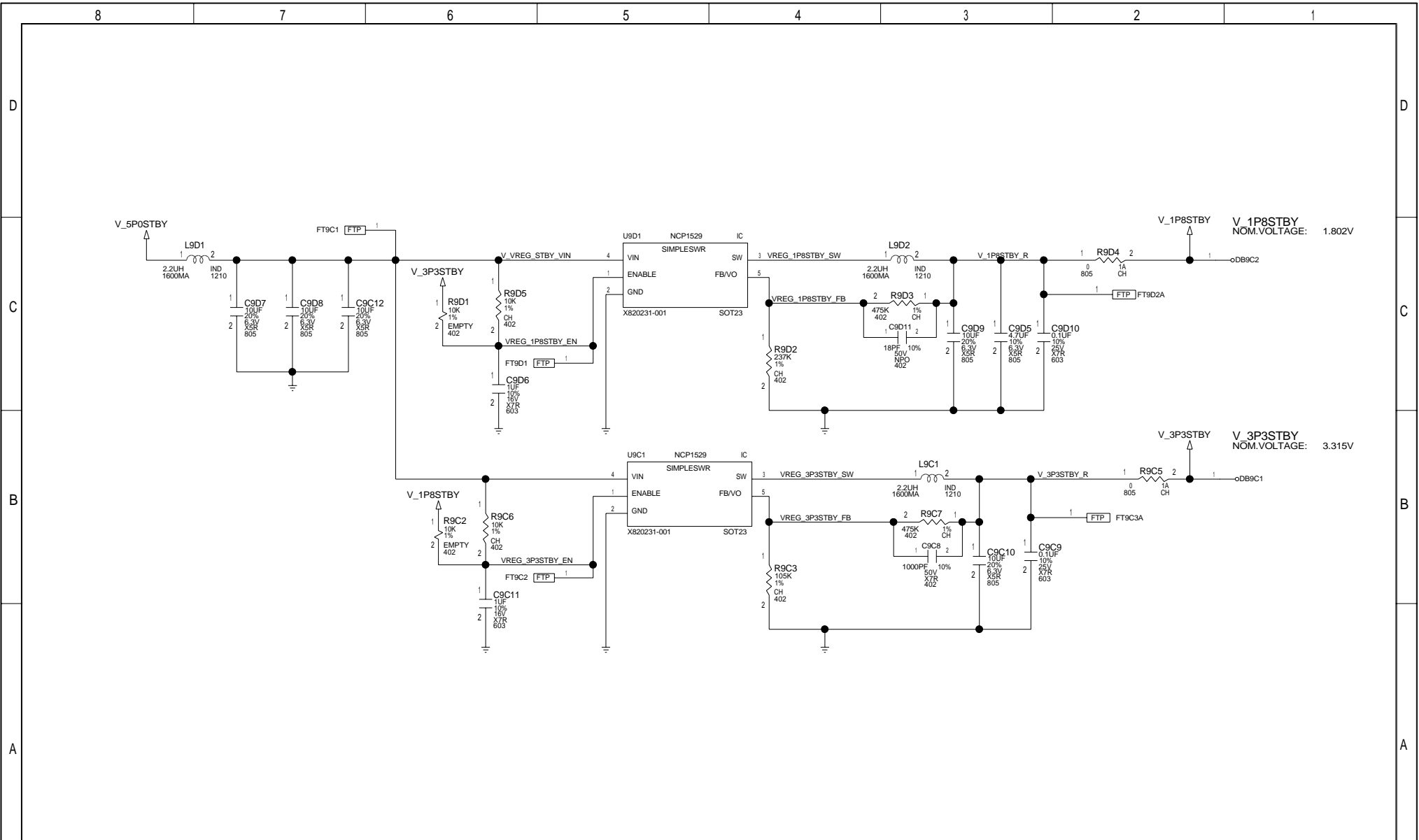

[PAGE_TITLE=VREGS, SWITCHED 1P8STBY AND 3P3STBY]

DRAWING
Thu Jan 29 11:47:56 2009

MICROSOFT CONFIDENTIAL	PROJECT H09517	NAME	PAGE 69/83	FAB A	REV A
---------------------------	-------------------	------	---------------	----------	----------

Title: Basenet Report
 Design: tonasket
 Date: Jan 29 11:43:07 2009

Base nets and synonyms for
 tonasket.lib.TONASKET(@tonasket.lib.tonas
 ket(sch_1))
 Base Signal
 Location([Zone][dir])

ADI_FREQ 55B5
 ADI_VREG 55D4 55A7 55B4
 ANA_CLK_OE 34B3 27C8
 ANA_CLK_OE_R 27C7
 ANA_PIX_CLK_2X_DN 27B1 13C8
 ANA_PIX_CLK_2X_DN_R 27C4
 ANA_PIX_CLK_2X_DP 27B1 13C8
 ANA_PIX_CLK_2X_DP_R 27C4
 ANA_RST_N 34C3 27D7
 ANA_V12P0_PWRGD 27D3 34C3 49A5
 ANA_VID_INT 28D3 33B2
 ANA_VRST_OK 27D3 34A8
 ARGONPORT_DN 35C3 49C8
 ARGONPORT_DP 35C3 49C8
 ARGON_CLK 34A1 49B7
 ARGON_DATA 34A1 49B7
 ARGON_DN_CM 49C6
 ARGON_DP_CM 49C6
 ARGON_NTX 45B6
 AUD_ACAP 41C5
 AUD_AC_L 41B5
 AUD_AC_R 41D5
 AUD_CLAMP 34C6 41A6
 AUD_CLAMP_B1 41A6
 AUD_CLAMP_B2 41A4
 AUD_CLAMP_B3 41A2
 AUD_CLAMP_C 41A5
 AUD_CLAMP_L 41B3
 AUD_CLAMP_R 41D3
 AUD_CLK 27A1 36C7
 AUD_CLK_R 27B4
 AUD_DCAP 41C7
 AUD_L_OUT 41C1 44B4
 AUD_RST_N 33B2 41C8
 AUD_R_OUT 41C1 44B4
 AUD_VAA 41D6
 AUD_VDD 41D7
 AUD_VOURL 41C6
 AUD_VOUTR 41C6
 AV_MODE0 44C1 34B8 44A3
 AV_MODE0_R 34B6
 AV_MODE1 44C1 34B8 44A3
 AV_MODE1_R 34B6
 AV_MODE2 44C1 34B8 44A3
 AV_MODE2_R 34B6
 BINDSW_N 43D6 34B3
 BINDSW_N_R 43D7

BLEEDER_B 47A4
 BLEEDER_C1 47A4
 BLEEDER_C2 47A3
 BLEEDER_V12P0_B1 49A3
 BLEEDER_V12P0_B2 49B2
 BLEEDER_V12P0_C1 49A3
 BLEEDER_V12P0_C2 49A2
 BLEEDER_V12P0_LOAD 49A2
 BND_GAP_CAP 28B6
 BRD_TEMP_N 28A5 28A8
 BRD_TEMP_P 28A1 28A5
 CAL_TEMP_N 28A1 28A8
 CAL_TEMP_P 28A3
 CPU_ANL_1 486
 CPU_ANL_2 486
 CPU_CHECKSTOP_N 59D1 58A1
 CPU_CHECKSTOP_N_LED 58B2
 CPU_CHECKSTOP_N_LED_B 58B3
 CPU_CHECKSTOP_N_LED_C 58B2
 CPU_CHECKSTOP_N_R 58A3
 CPU_CLK_DN 27D1 4D6
 CPU_CLK_DN_C 4D5
 CPU_CLK_DN_R 27C4
 CPU_CLK_DP 27D1 4D6
 CPU_CLK_DP_C 4D5
 CPU_CLK_DP_R 27C4
 CPU_CORE_IF_BGR_PLL 4D3
 CPU_DBGSEL_DEBUG<0..69> 47D3
 CPU_DBGSEL_XDK<0..69> 59D1 47D7
 CPU_DBG_CLK_DN 59D1
 CPU_DBG_CLK_DP 59D1
 CPU_EXT_CLK_EN 4C6
 CPU_FSB_CLK_SEL 4C6
 CPU_FSB_HF_CLKOUT_DN 4C2
 CPU_FSB_HF_CLKOUT_DP 4C2
 CPU_FSB_IMPED_CAL_DN 4C2
 CPU_FSB_IMPED_CAL_DP 4C2
 CPU_PLL_BYPASS 4C6
 CPU_POST_IN<0..4> 4C6
 CPU_PSRO0_OUT 4C3
 CPU_PULSE_LIMIT_BYPASS 4C6
 CPU_PWRGD 34B3 4D8
 CPU_PWRGD_V1P1_N 4D7
 CPU_RESO_DN 4C3
 CPU_RESO_DP 4C3
 CPU_RST_N 34B3 4D8
 CPU_RST_N_2_R 58A4
 CPU_RST_V1P1_N 4D8 58A6
 CPU_SPI_CLK 4B1 4A5
 CPU_SPI_CLK_R 4A4
 CPU_SPI_EN 4B2 4A6
 CPU_SPI_EN_R 4A4
 CPU_SPI_SI 4A1 4B6
 CPU_SPI_SI_R 4A2
 CPU_SPI_SO 4B2 4A5
 CPU_SPI_SO_R 4A4
 CPU_SPI_WP_N 4A2

CPU_SRVID 4B6 57D7
 CPU_SYS_CONFIG0 4C6
 CPU_SYS_CONFIG1 4C6
 CPU_TCLK 58A1 59D5
 CPU_TDI 58A5 59D5
 CPU_TDO 59D1 58A5
 CPU_TEMP_N 4B2 28A8
 CPU_TEMP_P 28A1 4B2
 CPU_TEST_EN 4B5
 CPU_TMS 58A5 59D5
 CPU_TRST_N 58A5 59D5
 CPU_VDDE 6C5
 CPU_VDDS0_DN 4C3
 CPU_VDDS0_DP 4C3
 CPU_VDDS1_DN 4C3
 CPU_VDDS1_DP 4C3
 CPU_VGATE 4B5
 CPU_VREG_APS0 4B2 50C7
 CPU_VREG_APS1 4B2 50D7
 CPU_VREG_APS2 4B2 50D7
 CPU_VREG_APS3 4B2 50D7
 CPU_VREG_APS4 4B2 50D7
 CPU_VREG_APS5 4B2 50D7
 DBG_CPU_LINKTRAINED 47C5
 DBG_CPU_PLL_LOCK 47C5
 DBG_CPU_POST_OUT0 47C5
 DBG_CPU_POST_OUT1 47C5
 DBG_CPU_POST_OUT2 47C5
 DBG_CPU_POST_OUT3 47C5
 DBG_CPU_POST_OUT4 47C5
 DBG_CPU_POST_OUT5 47C5
 DBG_CPU_POST_OUT6 47C5
 DBG_CPU_POST_OUT7 47C5
 DBG_CPU_SECURE_SYS 47C5
 DBG_CPU_TST_CLK 47C5
 DBG_LED0 34A8 34A6
 DBG_LED0_LED 34A4
 DBG_LED0_LED_R 34A5
 ECB_CLK_BYP 33D6
 ECB_CLK_SEL 33D6
 EDRAM_TEMP_N 13C8 28A8
 EDRAM_TEMP_P 28A1 13C8
 EJECTSW_N 43C6 34B3 48A1
 EJECTSW_N_R 43C7
 ENET_10BIAS 39B6
 ENET_10_100_OUT 39B5
 ENET_100BIAS 39B6
 ENET_ACT_N 39C3 40B3 45B4
 ENET_AMDIX_EN 39B6
 ENET_AVDD 40C4 40B3 40B6
 ENET_CLK 27A1 39C7 40C6
 ENET_CLK_R 27C4
 ENET_LINK_N 39B2 40B3 45B4
 ENET_P1CL 39B4
 ENET_P2LI_R 39B2 45B4
 ENET_P3TD 39B4
 ENET_P4RD 39B3

ENET_POAC_R 39C3 45B4
 ENET_RDAC 40B3
 ENET_REF_SYS_CLK2_OUT 40C5
 ENET_REF_CLK_OUT 39C6
 ENET_RST_N 33A2 39C8 40C6
 ENET_RX_CT 45B4
 ENET_RX_DN 39C1 40B3 45B4
 ENET_RX_DN_R 39C2
 ENET_RX_DP 39D1 40B3 45B4
 ENET_RX_DP_R 39D2
 ENET_TX_CT 45B4
 ENET_TX_DN 39A1 40B3 45B4
 ENET_TX_DN_R 39B2
 ENET_TX_DP 39C1 40B3 45B4
 ENET_TX_DP_R 39B2
 EN_TEST0_N 34A6
 EN_TEST1_N 34A6
 EXPPORT_DN 35B3 45C8
 EXPPORT_DN_CM 45C5
 EXPPORT_DP 35B3 45C8
 EXPPORT_DP_CM 45C5
 EXT_PWR_ON_DBG 58B5
 EXT_PWR_ON_N 44C1 58A1 58B3 34D8
 44A3
 EXT_PWR_ON_R 34C6
 FAN1_FDBK 43C2 28B6
 FAN1_FDBK_R 43C4
 FAN1_OUT 28B3 43D5
 FAN1_Q1_C 43D4
 FAN1_Q1_E 43C4
 FAN_OP1_DP 28B7
 FLSH_ALE 35C3 42B5
 FLSH_CE_N 35C3 42B5
 FLSH_CLE 35C3 42B5
 FLSH_DATA<7..0> 35C6 42C8
 FLSH_NC38 42C2
 FLSH_READY 42C1 35C7
 FLSH_RE_N 35C3 42B5
 FLSH_WE_N 35C3 42B5
 FLSH_WP_N 35C6 42B5
 FSB_BYPCLK_DN 12D7
 FSB_BYPCLK_DP 12D7
 FSB_BYPCLK_SEL 12D7
 FSB_CLK_DN 4C6
 FSB_CLK_DP 4C6
 FSB_CP_GP0_CLK_DN 5D3 12D8
 FSB_CP_GP0_CLK_DP 5D3 12D8
 FSB_CP_GP0_DATA0_DN 5C3 12C8
 FSB_CP_GP0_DATA0_DP 5C3 12C8
 FSB_CP_GP0_DATA1_DN 5C3 12C8
 FSB_CP_GP0_DATA1_DP 5C3 12C8
 FSB_CP_GP0_DATA2_DN 5C3 12C8
 FSB_CP_GP0_DATA2_DP 5C3 12C8
 FSB_CP_GP0_DATA3_DN 5C3 12C8
 FSB_CP_GP0_DATA3_DP 5C3 12C8
 FSB_CP_GP0_DATA4_DN 5C3 12C8
 FSB_CP_GP0_DATA4_DP 5C3 12C8

FSB_CP_GP0_DATA5_DN	5C3	12C8
FSB_CP_GP0_DATA5_DP	5C3	12C8
FSB_CP_GP0_DATA6_DN	5C3	12C8
FSB_CP_GP0_DATA6_DP	5C3	12C8
FSB_CP_GP0_DATA7_DN	5C3	12C8
FSB_CP_GP0_DATA7_DP	5C3	12C8
FSB_CP_GP0_FLAG_DN	5C3	12C8
FSB_CP_GP0_FLAG_DP	5C3	12C8
FSB_CP_GP1_CLK_DN	5C3	12C8
FSB_CP_GP1_CLK_DP	5C3	12C8
FSB_CP_GP1_DATA0_DN	5B3	12B8
FSB_CP_GP1_DATA0_DP	5B3	12B8
FSB_CP_GP1_DATA1_DN	5B3	12B8
FSB_CP_GP1_DATA1_DP	5B3	12B8
FSB_CP_GP1_DATA2_DN	5B3	12B8
FSB_CP_GP1_DATA2_DP	5B3	12B8
FSB_CP_GP1_DATA3_DN	5B3	12B8
FSB_CP_GP1_DATA3_DP	5B3	12B8
FSB_CP_GP1_DATA4_DN	5B3	12B8
FSB_CP_GP1_DATA4_DP	5B3	12B8
FSB_CP_GP1_DATA5_DN	5B3	12B8
FSB_CP_GP1_DATA5_DP	5B3	12B8
FSB_CP_GP1_DATA6_DN	5B3	12B8
FSB_CP_GP1_DATA6_DP	5B3	12B8
FSB_CP_GP1_DATA7_DN	5B3	12B8
FSB_CP_GP1_DATA7_DP	5B3	12B8
FSB_CP_GP1_FLAG_DN	5B3	12B8
FSB_CP_GP1_FLAG_DP	5B3	12C8
FSB_GP_CP0_CLK_DN	12D4	5D7
FSB_GP_CP0_CLK_DP	12D4	5D7
FSB_GP_CP0_DATA0_DN	12C4	5C7
FSB_GP_CP0_DATA0_DP	12C4	5C7
FSB_GP_CP0_DATA1_DN	12C4	5C7
FSB_GP_CP0_DATA1_DP	12C4	5C7
FSB_GP_CP0_DATA2_DN	12C4	5C7
FSB_GP_CP0_DATA2_DP	12C4	5C7
FSB_GP_CP0_DATA3_DN	12C4	5C7
FSB_GP_CP0_DATA3_DP	12C4	5C7
FSB_GP_CP0_DATA4_DN	12C4	5C7
FSB_GP_CP0_DATA4_DP	12C4	5C7
FSB_GP_CP0_DATA5_DN	12C4	5C7
FSB_GP_CP0_DATA5_DP	12C4	5C7
FSB_GP_CP0_DATA6_DN	12C4	5C7
FSB_GP_CP0_DATA6_DP	12C4	5C7
FSB_GP_CP0_DATA7_DN	12C4	5C7
FSB_GP_CP0_DATA7_DP	12C4	5C7
FSB_GP_CP0_FLAG_DN	12C4	5C7
FSB_GP_CP0_FLAG_DP	12C4	5C7
FSB_GP_CP1_CLK_DN	12C4	5C7
FSB_GP_CP1_CLK_DP	12C4	5C7
FSB_GP_CP1_DATA0_DN	12B4	5B7
FSB_GP_CP1_DATA0_DP	12B4	5B7
FSB_GP_CP1_DATA1_DN	12B4	5B7
FSB_GP_CP1_DATA1_DP	12B4	5B7
FSB_GP_CP1_DATA2_DN	12B4	5B7
FSB_GP_CP1_DATA2_DP	12B4	5B7
FSB_GP_CP1_DATA3_DN	12B4	5B7

FSB_GP_CP1_DATA3_DP	12B4	5B7
FSB_GP_CP1_DATA4_DN	12B4	5B7
FSB_GP_CP1_DATA4_DP	12B4	5B7
FSB_GP_CP1_DATA5_DN	12B4	5B7
FSB_GP_CP1_DATA5_DP	12B4	5B7
FSB_GP_CP1_DATA6_DN	12B4	5B7
FSB_GP_CP1_DATA6_DP	12B4	5B7
FSB_GP_CP1_DATA7_DN	12B4	5B7
FSB_GP_CP1_DATA7_DP	12B4	5B7
FSB_GP_CP1_FLAG_DN	12B4	5B7
FSB_GP_CP1_FLAG_DP	12C4	5B7
FSB_IMP_CAL	12B7	
FSB_IMP_NCAL	12B7	
GAMEPORT1_DN	35B6	46A8
GAMEPORT1_DN_CM	46B6	
GAMEPORT1_DP	35B6	46A8
GAMEPORT1_DP_CM	46B6	
GAMEPORT2_DN	35B6	46C8
GAMEPORT2_DN_CM	46B6	
GAMEPORT2_DP	35B6	46C8
GAMEPORT2_DP_CM	46B6	
GPU_CLK_DN	27D1	13D7
GPU_CLK_DN_R	27C4	
GPU_CLK_DP	27D1	13D7
GPU_CLK_DP_R	27C4	
GPU_HSYNC_OUT	13C4	28C6
GPU_PIX_CLK_1X	13C3	28D6
GPU_RST_DONE	13D3	34C1
GPU_RST_DONE_R	34B4	
GPU_RST_N	34B3	13D8
GPU_SCAN_BUFF_EN_N	13A7	12A3
GPU_SPI_CLK	13B3	13A7
GPU_SPI_CLK_R	13A5	
GPU_SPI_CS_N	13B3	13A7
GPU_SPI_CS_N_R	13A5	
GPU_SPI_SI	13A2	13B4 13C7
GPU_SPI_SO	13C3	13A7
GPU_SPI_SO_R	13A5	
GPU_SPI_WP_N	13B4	13A4
GPU_SROM_EN_PSRO_OUT	13C5	
GPU_TCLK	13B7	
GPU_TCLK_R	34A8	13C7
GPU_TDI	13B7	
GPU_TDO	13B7	
GPU_TEMP_N	13C8	28A8
GPU_TEMP_P	28A1	13C8
GPU_TMS	13B7	
GPU_TRST	13B7	
GPU_TRST_ED	13B7	
GPU_VSYNC_OUT	13C4	28C6
HANA_AV_CLK	27B4	
HANA_CLK_DRV_RSET1	27C6	
HANA_CLK_DRV_RSET2	27C6	
HANA_DAC_RSET	28C6	
HANA_OP2_DN	28A1	28B6
HANA_OP2_DP	28B6	
HANA_OP2_OUT	28A3	

HANA_POR_BYPASS	27D6	
HANA_SPDIF_OUT	28C3	44D6
HANA_TCLK	27B6	
HANA_TDI	27B6	
HANA_TDO	27B6	
HANA_TMS	27B6	
HANA_TRST	27B6	
HANA_V_12P0_DET	27D6	
HANA_V_12P0_DET_R	27D6	
HANA_XTAL_BYPASS	27C6	
HANA_XTAL_IN	27C6	
HANA_XTAL_OUT	27C6	
HANA_XTAL_VSS_CAP	27C6	
HBEDB_CLK_BYP	33D6	
HBEDB_CLK_SEL	33C6	
HDD_RX_DN	48C8	36B7
HDD_RX_DN_C	48C6	
HDD_RX_DP	48B8	36B7
HDD_RX_DP_C	48B6	
HDD_TX_DN	36B3	48D8
HDD_TX_DN_C	48D6	
HDD_TX_DP	36B3	48D8
HDD_TX_DP_C	48D6	
HDMI_CEC	29C3	
HDMI_DDC_CLK	28C3	34B8 44C1 29B5
HDMI_DDC_DATA	28C3	34C8 44C1 29B5
HDMI_EXT_SWING	28C4	
HDMI_HPD	29B1	28C6
HDMI_HPD_PIN	29B2	
HDMI_TX0_DN	28B1	29B8
HDMI_TX0_DN_CM	29C3	
HDMI_TX0_DP	28B1	29B8
HDMI_TX0_DP_CM	29C3	
HDMI_TX0_DP_R	28B2	
HDMI_TX1_DN	28B1	29C8
HDMI_TX1_DN_CM	29C3	
HDMI_TX1_DP	28B1	29C8
HDMI_TX1_DP_CM	29C3	
HDMI_TX1_DP_R	28B2	
HDMI_TX2_DN	28B1	29D8
HDMI_TX2_DN_CM	29C3	
HDMI_TX2_DP	28C1	29D8
HDMI_TX2_DP_CM	29C3	
HDMI_TX2_DP_R	28C2	
HDMI_TXC_DN	28C1	29A8
HDMI_TXC_DN_CM	29C3	
HDMI_TXC_DP	28C1	29A8
HDMI_TXC_DP_CM	29C3	
HDMI_TXC_DP_R	28C2	
I2S_BCLK	36C1	28C6 41C7
I2S_BCLK_R	36C4	
I2S_MCLK	36C1	41C7
I2S_MCLK_R	36C4	
I2S_SD	36C1	28B6 41C7
I2S_SD1	28C7	
I2S_SD2	28C7	
I2S_SD3	28C7	

I2S_SD_R	36C4	
I2S_WS	36B1	28C6 41C7
I2S_WS_R	36B4	
IR_DATA	43A1	34B6
KER_DBG_RXD	58D4	33C6
KER_DBG_TXD	33C1	58C6
KER_DBG_TXD_R	33C3	
LVLCNT	44B5	
MA_A<11..0>	19C8	20C8 14C5
MA_A<12..0>	14C5	
MA_BA<2..0>	14C5	19B8 20C8
MA_CAS_N	14B5	19B8 20B8
MA_CKE	14B5	19B8 20B8
MA_CLK0_DN	14C5	19C8
MA_CLK0_DP	14C5	19D8
MA_CLK1_DN	14C5	20C8
MA_CLK1_DP	14C5	20D8
MA_CS0_N	14B5	19B8
MA_CS1_N	14B5	19B1 20B8
MA_DM0	14B8	19B4 20B5
MA_DM1	14C8	19B4 20B5
MA_DM2	14C8	19C4 20C5
MA_DM3	14D8	19C4 20C5
MA_DQ0	14B8	19B4 20B5
MA_DQ1	14B8	19B4 20B5
MA_DQ2	14B8	19B4 20B5
MA_DQ3	14B8	19B4 20B5
MA_DQ4	14B8	19B4 20B5
MA_DQ5	14B8	19B4 20B5
MA_DQ6	14B8	19B4 20C5
MA_DQ7	14B8	19B4 20C5
MA_DQ8	14C8	19B4 20B5
MA_DQ9	14C8	19B4 20B5
MA_DQ10	14C8	19B4 20B5
MA_DQ11	14C8	19B4 20B5
MA_DQ12	14C8	19B4 20B5
MA_DQ13	14C8	19B4 20B5
MA_DQ14	14C8	19C4 20B5
MA_DQ15	14C8	19C4 20B5
MA_DQ16	14C8	19C4 20C5
MA_DQ17	14C8	19C4 20C5
MA_DQ18	14C8	19C4 20C5
MA_DQ19	14C8	19C4 20C5
MA_DQ20	14C8	19C4 20C5
MA_DQ21	14C8	19C4 20D5
MA_DQ22	14C8	19C4 20D5
MA_DQ23	14C8	19C4 20D5
MA_DQ24	14D8	19C4 20C5
MA_DQ25	14D8	19C4 20C5
MA_DQ26	14D8	19C4 20C5
MA_DQ27	14D8	19C4 20C5
MA_DQ28	14D8	19C4 20C5
MA_DQ29	14D8	19D4 20C5
MA_DQ30	14D8	19D4 20C5
MA_DQ31	14D8	19D4 20C5
MA_RAS_N	14B5	19B8 20B8
MA_RDQS0	19B4	20B5 14B8

MA_RDQS1	19B4	20B5	14C8
MA_RDQS2	19C4	20C5	14C8
MA_RDQS3	19C4	20C5	14D8
MA_VREF0	14A7		
MA_VREF1	14A8		
MA_WDQS0	14B8	19B4	20B5
MA_WDQS1	14C8	19B4	20B5
MA_WDQS2	14C8	19C4	20C5
MA_WDQS3	14D8	19C4	20C5
MA_WE_N	14B5	19B8	20B8
MA_ZQ_BOT	20B5		
MA_ZQ_TOP	19B5		
MB_A<11..0>	21C8	22C8	14C1
MB_A<12..0>	14C1		
MB_BA<2..0>	14C1	21B8	22B8
MB_CAS_N	14B1	21B8	22B8
MB_CKE	14B1	21B8	22B8
MB_CLK0_DN	14C1	21C8	
MB_CLK0_DP	14C1	21D8	
MB_CLK1_DN	14C1	22C8	
MB_CLK1_DP	14C1	22D8	
MB_CS0_N	14B1	21B8	
MB_CS1_N	14B1	21B1	22B8
MB_DM0	14B4	21B4	22B4
MB_DM1	14C4	21B4	22B4
MB_DM2	14C4	21C4	22C4
MB_DM3	14D4	21C4	22C4
MB_DQ0	14B4	21B5	22B5
MB_DQ1	14B4	21B5	22B5
MB_DQ2	14B4	21B5	22B5
MB_DQ3	14B4	21B5	22B5
MB_DQ4	14B4	21B5	22B5
MB_DQ5	14B4	21B5	22B5
MB_DQ6	14B4	21B5	22B5
MB_DQ7	14B4	21B5	22B5
MB_DQ8	14C4	21B5	22B5
MB_DQ9	14C4	21B5	22B5
MB_DQ10	14C4	21B5	22B5
MB_DQ11	14C4	21B5	22B5
MB_DQ12	14C4	21B5	22B5
MB_DQ13	14C4	21B5	22B5
MB_DQ14	14C4	21B5	22B5
MB_DQ15	14C4	21B5	22B5
MB_DQ16	14C4	21C5	22C5
MB_DQ17	14C4	21C5	22C5
MB_DQ18	14C4	21C5	22C5
MB_DQ19	14C4	21C5	22C5
MB_DQ20	14C4	21C5	22C5
MB_DQ21	14C4	21C5	22C5
MB_DQ22	14C4	21C5	22C5
MB_DQ23	14C4	21C5	22D5
MB_DQ24	14D4	21C5	22C5
MB_DQ25	14D4	21C5	22C5
MB_DQ26	14D4	21C5	22C5
MB_DQ27	14D4	21C5	22C5
MB_DQ28	14D4	21C5	22C5
MB_DQ29	14D4	21C5	22C5

MB_DQ30	14D4	21C5	22C5
MB_DQ31	14D4	21D5	22C5
MB_RAS_N	14B1	21B8	22B8
MB_RDQS0	21B4	22B4	14B4
MB_RDQS1	21B4	22B4	14C4
MB_RDQS2	21C4	22C4	14C4
MB_RDQS3	21C4	22C4	14D4
MB_VREF0	14A4		
MB_VREF1	14A4		
MB_WDQS0	14B4	21B4	22B4
MB_WDQS1	14C4	21B4	22B4
MB_WDQS2	14C4	21C4	22C4
MB_WDQS3	14D4	21C4	22C4
MB_WE_N	14B1	21B8	22B8
MB_ZQ_BOT	22A5		
MB_ZQ_TOP	21A5		
MC_A<11..0>	23C8	24C8	15C5
MC_A<12..0>	15C5		
MC_BA<2..0>	15C5	23B8	24B8
MC_CAS_N	15B5	23B8	24B8
MC_CKE	15C5	23B8	24B8
MC_CLK0_DN	15C5	23C8	
MC_CLK0_DP	15C5	23D8	
MC_CLK1_DN	15C5	24C8	
MC_CLK1_DP	15D5	24D8	
MC_CS0_N	15B5	23B8	
MC_CS1_N	15B5	23B1	24B8
MC_DM0	15B8	23B4	24B4
MC_DM1	15C8	23B4	24B4
MC_DM2	15C8	23C4	24C4
MC_DM3	15D8	23C4	24C4
MC_DQ0	15B8	23B4	24B4
MC_DQ1	15B8	23B4	24B4
MC_DQ2	15B8	23B4	24B4
MC_DQ3	15B8	23B4	24B4
MC_DQ4	15B8	23B4	24B4
MC_DQ5	15B8	23B4	24B4
MC_DQ6	15B8	23B4	24B4
MC_DQ7	15B8	23B4	24C4
MC_DQ8	15C8	23B4	24B4
MC_DQ9	15C8	23B4	24B4
MC_DQ10	15C8	23B4	24B4
MC_DQ11	15C8	23B4	24B4
MC_DQ12	15C8	23B4	24B4
MC_DQ13	15C8	23B4	24B4
MC_DQ14	15C8	23C4	24B4
MC_DQ15	15C8	23C4	24B4
MC_DQ16	15C8	23C4	24C4
MC_DQ17	15C8	23C4	24C4
MC_DQ18	15C8	23C4	24C4
MC_DQ19	15C8	23C4	24C4
MC_DQ20	15C8	23C4	24C4
MC_DQ21	15C8	23C4	24C4
MC_DQ22	15C8	23C4	24D4
MC_DQ23	15D8	23C4	24D4
MC_DQ24	15D8	23C4	24C4
MC_DQ25	15D8	23C4	24C4

MC_DQ26	15D8	23C4	24C4
MC_DQ27	15D8	23C4	24C4
MC_DQ28	15D8	23C4	24C4
MC_DQ29	15D8	23D4	24C4
MC_DQ30	15D8	23D4	24C4
MC_DQ31	15D8	23D4	24C4
MC_RAS_N	15B5	23B8	24B8
MC_RDQS0	23B4	24B4	15B8
MC_RDQS1	23B4	24B4	15C8
MC_RDQS2	23C4	24C4	15C8
MC_RDQS3	23C4	24C4	15D8
MC_VREF0	15A7		
MC_VREF1	15A8		
MC_WDQS0	15B8	23B4	24B4
MC_WDQS1	15C8	23B4	24B4
MC_WDQS2	15C8	23C4	24C4
MC_WDQS3	15D8	23C4	24C4
MC_WE_N	15B5	23B8	24B8
MC_ZQ_BOT	24B5		
MC_ZQ_TOP	23B5		
MD_A<11..0>	25C8	26C8	15C1
MD_A<12..0>	15C1		
MD_BA<2..0>	15C1	25C8	26B8
MD_CAS_N	15B1	25B8	26B8
MD_CKE	15C1	25B8	26B8
MD_CLK0_DN	15C1	25C8	
MD_CLK0_DP	15C1	25D8	
MD_CLK1_DN	15C1	26C8	
MD_CLK1_DP	15D1	26D8	
MD_CS0_N	15B1	25B8	
MD_CS1_N	15B1	25B1	26B8
MD_DM0	15B4	25B4	26B4
MD_DM1	15C4	25B4	26B4
MD_DM2	15C4	25C4	26C4
MD_DM3	15D4	25C4	26C4
MD_DQ0	15B4	25B4	26B5
MD_DQ1	15B4	25B4	26B5
MD_DQ2	15B4	25B4	26B5
MD_DQ3	15B4	25B4	26B5
MD_DQ4	15B4	25B4	26B5
MD_DQ5	15B4	25B4	26B5
MD_DQ6	15B4	25B4	26C5
MD_DQ7	15B4	25B4	26C5
MD_DQ8	15C4	25B4	26B5
MD_DQ9	15C4	25B4	26B5
MD_DQ10	15C4	25B4	26B5
MD_DQ11	15C4	25B4	26B5
MD_DQ12	15C4	25C4	26B5
MD_DQ13	15C4	25C4	26B5
MD_DQ14	15C4	25C4	26B5
MD_DQ15	15C4	25C4	26B5
MD_DQ16	15C4	25C4	26C5
MD_DQ17	15C4	25C4	26C5
MD_DQ18	15C4	25C4	26C5
MD_DQ19	15C4	25C4	26C5
MD_DQ20	15C4	25C4	26C5
MD_DQ21	15C4	25C4	26D5

MD_DQ22	15C4	25C4	26D5
MD_DQ23	15D4	25C4	26D5
MD_DQ24	15D4	25C4	26C5
MD_DQ25	15D4	25C4	26C5
MD_DQ26	15D4	25C4	26C5
MD_DQ27	15D4	25D4	26C5
MD_DQ28	15D4	25D4	26C5
MD_DQ29	15D4	25D4	26C5
MD_DQ30	15D4	25D4	26C5
MD_DQ31	15D4	25D4	26C5
MD_RAS_N	15B1	25B8	26B8
MD_RDQS0	25B4	26B4	15B4
MD_RDQS1	25B4	26B4	15C4
MD_RDQS2	25C4	26C4	15C4
MD_RDQS3	25C4	26C4	15D4
MD_VREF0	15A3		
MD_VREF1	15A4		
MD_WDQS0	15B4	25B4	26B4
MD_WDQS1	15C4	25B4	26B4
MD_WDQS2	15C4	25C4	26C4
MD_WDQS3	15D4	25C4	26C4
MD_WE_N	15B1	25B8	26B8
MD_ZQ_BOT	26B5		
MD_ZQ_TOP	25B5		
MEMPORT1_DN	35C3	46B4	
MEMPORT1_DN_CM	46B2		
MEMPORT1_DP	35C3	46B4	
MEMPORT1_DP_CM	46B2		
MEMPORT2_DN	35B3	46C4	
MEMPORT2_DN_CM	46C2		
MEMPORT2_DP	35B3	46C4	
MEMPORT2_DP_CM	46C2		
MEMPORT3_DN	35B3		
MEMPORT3_DP	35B3		
MEM_A_VREF0	20A6	19B8	20B8
MEM_A_VREF1	19A6	19B8	20B8
MEM_B_VREF0	22A6	21B8	22B8
MEM_B_VREF1	21A6	21B8	22B8
MEM_CALA	13B7		
MEM_CALB	13B7		
MEM_C_VREF0	24A6	23B8	24B7
MEM_C_VREF1	23A6	23B8	24B7
MEM_D_VREF0	26A7	25B7	26B8
MEM_D_VREF1	25A6	25B7	26B8
MEM_RST	13B3	19C8	20C8 21C8
22C8 23C8 24C8 25C8 26C8			
MEM_SCAN_BOT_EN	12A1	20B8	22B8 24B8
26B8			
MEM_SCAN_BOT_EN_BUFF	13B3	12A4	
MEM_SCAN_EN	12D1	19B8	20B8 21B8
22B8 23B8 24B8 25B8 26B8			
MEM_SCAN_EN_BUFF	13B3	12D4	
MEM_SCAN_TOP_EN	12B1	19B8	21B8 23B8
25B8			
MEM_SCAN_TOP_EN_BUFF	13B3	12B4	
MII_COL	39B7	40B6	36C7
MII CRS	39B7	40B6	36C7

MII_MDC_CLK_OUT	36C2	39C8	40B6
MII_MDC_CLK_OUT_R	36C4		
MII_MDIO	36C7	39B8	40B6
MII_RXD0	39C7	40B7	36C7
MII_RXD1	39C7	40B6	36C7
MII_RXD2	39C7	40B6	36C7
MII_RXD3	39C7	40B6	36C7
MII_RXDV	39C7	40B6	36C7
MII_RXER	39C7	40B6	36C7
MII_RX_CLK	39C7	40C6	36C8
MII_RX_CLK_R	36C7		
MII_TXD0	36C4	39B7	40B6
MII_TXD1	36C4	39B7	40B6
MII_TXD2	36C4	39B7	40B6
MII_TXD3	36C4	39C7	40B6
MII_TXEN	36C3	39C7	40B6
MII_TX_CLK	39C7	40B6	36D8
MII_TX_CLK_R	36D7		
ODD_RX_DN	48A8	36B7	
ODD_RX_DN_C	48A7		
ODD_RX_DP	48A8	36B7	
ODD_RX_DP_C	48A7		
ODD_TX_DN	36B3	48A8	
ODD_TX_DN_C	48A7		
ODD_TX_DP	36B3	48B8	
ODD_TX_DP_C	48B7		
PCIE_CLK_DN	27C1	33C6	
PCIE_CLK_DN_R	27C4		
PCIE_CLK_DP	27C1	33C6	
PCIE_CLK_DP_R	27C4		
PCIE_INT	33B3		
PEX_GPU_SB_L0_DN	13C1	33C7	
PEX_GPU_SB_L0_DN_C	13D4		
PEX_GPU_SB_L0_DP	13D1	33C7	
PEX_GPU_SB_L0_DP_C	13D4		
PEX_GPU_SB_L1_DN	13D1	33C7	
PEX_GPU_SB_L1_DN_C	13D4		
PEX_GPU_SB_L1_DP	13D1	33C7	
PEX_GPU_SB_L1_DP_C	13D4		
PEX_ICAL	13C8		
PEX_NCAL	13D7		
PEX_PCAL	13D8		
PEX_RBIA50	33C6		
PEX_RBIA51	33C6		
PEX_SB_GPU_L0_DN	33C1	13D8	
PEX_SB_GPU_L0_DN_C	33C3		
PEX_SB_GPU_L0_DP	33C1	13D8	
PEX_SB_GPU_L0_DP_C	33C3		
PEX_SB_GPU_L1_DN	33D1	13D8	
PEX_SB_GPU_L1_DN_C	33C3		
PEX_SB_GPU_L1_DP	33D1	13D8	
PEX_SB_GPU_L1_DP_C	33C3		
PIX_DATA<14..0>	13C3	28D6	
PSU_V12P0_EN	34B3	49C5	
PSU_V12P0_EN_R	49C2		
PWR5W_N	34C3	49B8	
PWR5W_N_R	49B7		

SATA_CLK_DN	27B1	33D6	
SATA_CLK_DN_R	27C4		
SATA_CLK_DP	27C1	33D6	
SATA_CLK_DP_R	27C4		
SATA_CLK_REF	27B1	33D6	
SATA_CLK_REF_R	27C4		
SATA_CLK_SEL	33D6		
SATA_BIAS	36B6		
SB_GPIO<0..15>	33B1	33B5	
SB_GPIO_RESERVED6	33B3		
SB_GPIO_RESERVED16	33B3		
SB_GPIO_RESERVED17	33B3		
SB_GPIO_RESERVED18	33B3		
SB_GPIO_RESERVED19	33B3		
SB_GPIO_RESERVED20	33B3		
SB_GPIO_RESERVED21	33B3		
SB_GPIO_RESERVED22	33B3		
SB_GPIO_RESERVED23	33B3		
SB_GPIO_RESERVED24	33B3		
SB_GPIO_RESERVED25	33B3		
SB_GPIO_RESERVED26	33B3		
SB_GPIO_RESERVED27	33B3		
SB_GPIO_RESERVED28	33B3		
SB_GPIO_RESERVED29	33C3		
SB_GPIO_RESERVED30	33C3		
SB_GPIO_RESERVED31	33C3		
SB_MAIN_PWRGD	34B1	34C6	
SB_MAIN_PWRGD_R	34B4		
SB_RST_N	34B3	34C6	
SB_SPDIF_OUT	36B1	28C6	
SB_TCLK	33A5		
SB_TDI	33A5		
SB_TDO	33A5		
SB_TMS	33A5		
SB_TRST	33A5		
SB_USB_RBIA5	35B6		
SCART_RGB	33B2	44A6	
SCART_RGB_OUT	44A3		
SCART_RGB_OUT_R	44A4		
SCART_RGB_R	44A5		
SMB_CLK	34B8	58B7	27B6
SMB_CLK_R	58C6		
SMB_DATA	27B7	34B8	58C3
SMB_DATA_R	58C5		
SMC_CPU_CHKSTOP_DETECT	34C8	58A1	
SMC_CPU_CHKSTOP_DETECT_B	58A2		
SMC_DBG_EN	58C6	34C6	
SMC_DBG_TXD	34C3	58C6	
SMC_DBG_TXD_R	34C4		
SMC_PWM0	34B3	28B8	
SMC_PWM1	34B4		
SMC_RST_N	27D3	34D6	47A5 58D3
SMC_RST_N_R	27D4		
SMC_RST_XDK_N	58C5		
SPDIF_R	36B4		
SPI_CLK	58D6	35D6	
SPI_MISO	35D2	58D8	

SPI_MISO_R	35D4		
SPI_MOSI	58D6	35D6	
SPI_SS_N	58D8	35D6	
STBY_CLK	27A1	34D6	
STBY_CLK_R	27C4		
TEMP_RSET	28B6		
TILT5W_N	43B6	34B3	
TILT5W_N_R	43A7		
TRAY_OPEN	34D8	48A1	
TRAY_OPEN_R	34C6		
TRAY_STATUS	48A4	34C6	
TRAY_STATUS_R	48A3		
USBPORTA2_DN	35C6		
USBPORTA2_DP	35C6		
USBPORTA3_DN	35C6		
USBPORTA3_DP	35C6		
VID_DACA_DN	28D4		
VID_DACA_DP	28D3	44D8	
VID_DACA_OUT	44D5	44C4	
VID_DACB_DN	28D4		
VID_DACB_DP	28D3	44C8	
VID_DACB_OUT	44C6	44C4	
VID_DACC_DN	28D4		
VID_DACC_DP	28D3	44C8	
VID_DACC_OUT	44C6	44C4	
VID_DACD_DN	28D4		
VID_DACD_DP	28D3	44B8	
VID_DACD_OUT	44B6	44C4	
VID_HSYNC_OUT	44A4	44C4	
VID_HSYNC_OUT_R	28C3	44A7	
VID_VSYNC_OUT	44A6	44C4	
VID_VSYNC_OUT_R	28C3	44A8	
VREG_1P8STBY_ADJ	56A7		
VREG_1P8STBY_D1	56B8		
VREG_1P8STBY_D2	56B7		
VREG_1P8STBY_EN	62C6		
VREG_1P8STBY_FB	62C4		
VREG_1P8STBY_IN	56B8		
VREG_1P8STBY_SW	62C4		
VREG_3P3STBY_EN	62B6		
VREG_3P3STBY_FB	62B4		
VREG_3P3STBY_SW	62B4		
VREG_3P3_EN	34C3	56D8	
VREG_3P3_EN_R	56D6		
VREG_CPU1_VCC	52B7		
VREG_CPU2_VCC	52C7		
VREG_CPUPLL_ADJUST	56A2		
VREG_CPUPLL_IN	56A4		
VREG_CPUPLL_R	56A1		
VREG_CPU_BG1	52A5		
VREG_CPU_BG2	52B5		
VREG_CPU_BST1	52B6		
VREG_CPU_BST1_R	52A5		
VREG_CPU_BST2	52C6		
VREG_CPU_BST2_R	52C5		
VREG_CPU_COMP	51A5		
VREG_CPU_COMP_R	51A6		

VREG_CPU_CSCOMP	51C5		
VREG_CPU_CSCOMP_R	51B6		
VREG_CPU_CSREF	51A6		
VREG_CPU_CSREF_R	51A5		
VREG_CPU_CSSUM	51B6		
VREG_CPU_DELAY	51B3		
VREG_CPU_DRVH1	52A5		
VREG_CPU_DRVH2	52B5		
VREG_CPU_DRV_EN	51B1	52C8	
VREG_CPU_EN	34B3	51D7	
VREG_CPU_FB	51A6		
VREG_CPU_FBRN	51B5		
VREG_CPU_PHASE1	52A1	51C8	
VREG_CPU_PHASE1_R	51C5		
VREG_CPU_PHASE2	52C1	51C8	
VREG_CPU_PHASE2_R	51C5		
VREG_CPU_PWM1	51B3	52A7	
VREG_CPU_PWM2	51C3	52B7	
VREG_CPU_PWM3	51C3		
VREG_CPU_PWRGD	51C2	34C1	
VREG_CPU_RAMPADJ	51C5		
VREG_CPU_RAMPADJ_R	51D5		
VREG_CPU_RT	51B3		
VREG_CPU_SW1_R	52A2		
VREG_CPU_SW2_R	52B2		
VREG_CPU_SW4	51C5		
VREG_CPU_VCC	51D6		
VREG_CPU_VID<5..0>	50C2	51C2	
VREG_EFUSE_EN	4D2	56C6	
VREG_EFUSE_EN_C1	56C4		
VREG_EFUSE_EN_C2	56D3		
VREG_EFUSE_EN_R	56C4		
VREG_GPUPCIE_IN	56C4		
VREG_GPU_5VREF	53C3	53C6	
VREG_GPU_COMP	53C6		
VREG_GPU_COMP_C	53C8		
VREG_GPU_COMP_R	53C7		
VREG_GPU_CPGD	53B6		
VREG_GPU_CS1	53C6		
VREG_GPU_CS2	53C6		
VREG_GPU_CSREF	53C6		
VREG_GPU_CSREF_R	53A8		
VREG_GPU_EN_N	34C3	53B3	
VREG_GPU_EN_N_R	53B1		
VREG_GPU_GH1	53A1	54C7	
VREG_GPU_GH1_R	53A3		
VREG_GPU_GH2	53A1	54D7	
VREG_GPU_GH2_R	53A3		
VREG_GPU_GL1	53A1	54B7	
VREG_GPU_GL1_R	53A3		
VREG_GPU_GL2	53A1	54C7	
VREG_GPU_GL2_R	53A3		
VREG_GPU_L1M	53C4		
VREG_GPU_NPNC	53C2		
VREG_GPU_PH1_R	54B3		
VREG_GPU_PH2_R	54C3		
VREG_GPU_PHASE1	53D1	54B2 53B8	

VREG_GPU_PHASE1_C	53D2	
VREG_GPU_PHASE2	54D2	53B8
VREG_GPU_PWRGD	53A1	34D1
VREG_GPU_ROSC	53B6	
VREG_GPU_SEN	53C6	
VREG_GPU_VCCH	53C4	
VREG_GPU_VCCL	53C6	
VREG_GPU_VDRP	53C6	
VREG_GPU_VFB	53C6	
VREG_GPU_VFB_R	53D8	
VREG_GPU_VFFB	53D8	61C5
VREG_GPU_VID0	53C3	61C5
VREG_GPU_VID1	53D3	61C5
VREG_GPU_VID2	53D4	61C5
VREG_GPU_VID3	53D4	61C5
VREG_GPU_VID4	53D4	61C5
VREG_PCIEX_ADJUST	56B3	
VREG_PCIEX_R	56B1	
VREG_V1P8_BST1	55C4	
VREG_V1P8_COMP1	55B4	
VREG_V1P8_COMP1_R	55B3	
VREG_V1P8_CSL1	55C4	
VREG_V1P8_CSL1_R	55C4	
VREG_V1P8_DH1	55C4	
VREG_V1P8_DL1	55C4	
VREG_V1P8_EN	34B3	55A3
VREG_V1P8_FB1	55A1	61B5
VREG_V1P8_FB1_C	55B1	
VREG_V1P8_FB1_R	55A1	
VREG_V1P8_SS1	55B4	
VREG_V1P8_SW1	55C4	
VREG_V1P8_SW1_S	55C3	
VREG_V3P3_ADJ	56D5	
VREG_V5P0_BST2	55C6	
VREG_V5P0_COMP2	55B6	
VREG_V5P0_COMP2_R	55B7	
VREG_V5P0_CSL2	55C6	
VREG_V5P0_CSL2_R	55C6	
VREG_V5P0_DH2	55C6	
VREG_V5P0_DL2	55C6	
VREG_V5P0_EN	34B3	55A8
VREG_V5P0_EN_R	55A6	
VREG_V5P0_FB2	55B8	
VREG_V5P0_FB2_C	55B8	
VREG_V5P0_FB2_R	55B8	
VREG_V5P0_SEL	34B3	47B8
VREG_V5P0_SEL_B1	47B7	
VREG_V5P0_SEL_B2	47B6	
VREG_V5P0_SEL_C	47B7	
VREG_V5P0_SEL_NGATE	47B6	
VREG_V5P0_SEL_PGATE	47B6	
VREG_V5P0_SS2	55B5	
VREG_V5P0_SW2	55C6	
VREG_V5P0_SW2_S	55C7	
VREG_V5P0_VMEM_PWRGD	34A8	55A7
VREG_VCS_COMP	57B6	
VREG_VCS_COMP_C	57B6	

VREG_VCS_COMP_R	57A6	
VREG_VCS_CPUCORE_R	57B8	
VREG_VCS_FB	57B5	
VREG_VCS_FB_COMP	57B3	
VREG_VCS_FB_R	57B3	
VREG_VCS_HDRV	57C4	
VREG_VCS_LDRV	57C4	
VREG_VCS_LTO	57C8	
VREG_VCS_NC	57B4	
VREG_VCS_NC1	57B4	
VREG_VCS_RT	57C5	
VREG_VCS_SS_SD_N	57C7	
VREG_VCS_VOUT_L	57C3	
VREG_VCS_VP	57C5	
VREG_VCS_VREF	57C5	
VREG_VDD_PEX_ADJ	56A7	
VREG_VDD_PEX_R	56A5	
VREG_V_CPUCORE_S	51A7	
VREG_V_MEM_S_0	55B1	
V_1P8STBY_R	62C3	
V_3P3STBY_R	62B3	
V_AVDD0_SATA	38B6	
V_AVDD1_SATA	38C6	
V_AVDD_PEX	38D6	
V_AVDD_USB	37C6	
V_AVIP	44D3	29D3
V_AVSS0_SATA	38B6	
V_AVSS1_SATA	38C6	
V_AVSS_PEX	38D6	
V_AVSS_USB	37C6	
V_CMPAVDD18_USB	37C6	
V_CMPAVDD33_USB	37A7	37C2
V_CMPAVDD_SATA	38B6	
V_CMPAVSS18_USB	37C6	
V_CMPAVSS33_USB	37C6	
V_CMPAVSS_SATA	38B6	
V_CPU_CORE_HF_GNDA_PLL	6C5	
V_CPU_CORE_HF_VDDA_PLL	6C5	
V_CPU_CORE_IF_GNDA_PLL	6C5	
V_CPU_CORE_IF_VDDA_PLL	6C5	
V_CPU_FSB_HF_GNDA_PLL	6C5	
V_CPU_FSB_HF_VDDA_PLL	6C5	
V_CPU_FSB_IF_GNDA_PLL	6B5	
V_CPU_FSB_IF_VDDA_PLL	6B5	
V_CPU_GNDA_RNG	6B5	
V_CPU_VDDA_RNG	6B5	
V_ENET	39A3	39B8 39B8 39D5
40B3 40C7 45B6		
V_EXPPORT	45D2	45B6 45D7
V_FAN1	43C3	
V_GAMEPORT1	46B7	
V_GAMEPORT2	46D7	
V_HANA_VAA_DAC33M	30C7	
V_HANA_VAA_RTS33S	30D6	
V_HANA_VAA_XTAL_33S	30C7	
V_HANA_VDD18S	31D3	
V_HANA_VDDIO_33S_AVCC	31C7	

V_HANA_VDDIO_33S_PVCC0	31B6	
V_HDD	48B4	
V_IR	43A3	
V_MEMPORT1	46C3	
V_MEMPORT2	46D2	
V_PVDDA	16C4	
V_PVDDA_ED	16C5	
V_PVDDA_FSB	16B5	
V_PVDDA_MEM	16C5	
V_V3P3TOV1P8	54A6	
V_VDD18_USB	37C6	
V_VDD33_USB	37B5	
V_VDD_PEX_FB	38D6	
V_VDD_SATA	38B6	
V_VREG_CPU	50B4	51D6 51D7 52C5
52D8		
V_VREG_GPU	50B1	53D4 53D7 54D7
V_VREG_STBY_VIN	62C6	
V_VREG_V1P8V5P0	55D4	32D4
V_VREG_VCS	57D2	
V_XPOD	48B3	
WSS_CNTL0	33B2	44B6
WSS_CNTL1	33B2	44B6
WSS_CNTL_B	44B4	
WSS_CNTL_E	44B5	
WSS_CNTL_OUT	44B3	
WSS_CNTL_OUT_R	44B4	
XUSB_CLK_BYP	33C6	
XUSB_CLK_SEL	33C6	

Title: Cref Part Report
 Design: tonasket
 Date: Jan 29 11:43:07 2009

C1A2 CAPN_402 [45B3]
 C1A3 CAPN_402 [45D4]
 C1A4 CAPN_402 [45B5]
 C1A5 CAP_P_RDL [39A7]
 C1B1 CAPN_805 [39A6]
 C1B2 CAPN_402 [32B5]
 C1B3 CAPN_402 [32B5]
 C1B4 CAPN_402 [27A5]
 C1C1 CAPN_402 [32B5]
 C1C2 CAPN_402 [33A3]
 C1C3 CAPN_402 [48A7]
 C1C4 CAPN_402 [48A7]
 C1C5 CAPN_402 [48A7]
 C1C6 CAPN_402 [48B7]
 C1C7 CAPN_402 [32C6]
 C1C8 CAPN_402 [32D4]
 C1C9 CAPN_402 [36B6]
 C1C10 CAP_P_RDL [48A6]
 C1C11 CAP_P_RDL [48A5]
 C1C12 CAPN_402 [32B5]
 C1C13 CAPN_603 [48A5]
 C1C14 CAPN_603 [48A6]
 C1C15 CAPN_402 [32B7]
 C1D1 CAPN_603 [48A5]
 C1D2 CAPN_805 [38C2]
 C1D3 CAPN_402 [48A5]
 C1D4 CAPN_603 [48A6]
 C1D6 CAPN_603 [48A5]
 C1D7 CAPN_402 [58D6]
 C1D8 CAPN_402 [32C5]
 C1D9 CAP_P_RDL [48A6]
 C1D10 CAPN_402 [32B5]
 C1D11 CAP_P_RDL [47B5]
 C1E1 CAPN_402 [48B7]
 C1E2 CAPN_402 [48C7]
 C1E3 CAPN_402 [48D7]
 C1E4 CAPN_402 [48D7]
 C1E5 CAP_P_RDL [48B4]
 C1F1 CAPN_402 [32C4]
 C1F2 CAPN_402 [32B5]
 C1F3 CAP_P_RDL [56D4]
 C1F4 CAP_P_RDL [46A2]
 C1F5 CAPN_603 [56D5]
 C1F6 CAPN_603 [46A2]
 C1G1 CAPN_402 [32B5]
 C1M1 CAPN_402 [45B4]
 C1M2 CAPN_805 [45D4]
 C1N1 CAPN_402 [39A6]
 C1N2 CAPN_402 [39A4]
 C1N3 CAPN_402 [39A5]
 C1N4 CAPN_402 [39A5]
 C1N5 CAPN_402 [39A5]

C1N6 CAPN_402 [40A5]
 C1N7 CAPN_805 [40C4]
 C1N8 CAPN_805 [40C5]
 C1N9 CAPN_402 [39A5]
 C1N10 CAPN_402 [39A4]
 C1N11 CAPN_402 [39A4]
 C1N12 CAPN_402 [32C6]
 C1N13 CAPN_402 [32B5]
 C1N14 CAPN_402 [40C4]
 C1P1 CAPN_402 [38A6]
 C1P2 CAPN_805 [38B8]
 C1P3 CAPN_603 [38B7]
 C1P4 CAPN_402 [38B7]
 C1P5 CAPN_603 [38B7]
 C1P6 CAPN_402 [38B7]
 C1P7 CAPN_805 [38B8]
 C1P8 CAPN_805 [38A7]
 C1P9 CAPN_402 [27A7]
 C1P10 CAPN_603 [38A7]
 C1P11 CAPN_402 [38A7]
 C1P13 CAPN_402 [28A5]
 C1R1 CAPN_402 [48A4]
 C1R2 CAPN_402 [58C7]
 C1R3 CAPN_402 [47B5]
 C1R4 CAPN_402 [48A1]
 C1T1 CAPN_603 [48B3]
 C1T2 CAPN_402 [48B3]
 C1T3 CAPN_402 [48B3]
 C1T4 CAPN_603 [48B3]
 C1T5 CAPN_603 [48B4]
 C1U1 CAPN_805 [56D6]
 C1U2 CAPN_805 [46A3]
 C2A1 CAPN_402 [44D3]
 C2A3 CAPN_402 [44A2]
 C2A4 CAP_P_RDL [45D4]
 C2A6 CAPN_402 [44D5]
 C2A7 CAPN_1206 [41D6]
 C2A8 CAPN_402 [44B4]
 C2A9 CAPN_402 [29D3]
 C2B1 CAPN_805 [41C7]
 C2B2 CAPN_402 [41B2]
 C2B3 CAPN_402 [41C2]
 C2B4 CAPN_402 [41C5]
 C2B5 CAPN_402 [41C7]
 C2B6 CAPN_402 [41C7]
 C2B7 CAPN_603 [41D6]
 C2B8 CAPN_805 [41C5]
 C2B9 CAP_P_1206 [41B5]
 C2B10 CAP_P_1206 [41D5]
 C2B11 CAPN_805 [41C7]
 C2B12 CAPN_402 [58C4]
 C2B14 CAPN_402 [27A5]
 C2B15 CAPN_603 [58C4]
 C2B16 CAPN_402 [33A3]
 C2B17 CAPN_402 [27A4]
 C2C1 CAPN_402 [33D2]
 C2C2 CAPN_402 [33D2]

C2C3 CAPN_402 [33C2]
 C2C4 CAPN_402 [33C2]
 C2C5 CAPN_805 [56A8]
 C2C6 CAPN_402 [56A7]
 C2D1 CAPN_402 [25A2]
 C2D11 CAPN_402 [25A3]
 C2D2 CAPN_805 [23A4]
 C2D4 CAPN_402 [25A1]
 C2D5 CAPN_402 [12A3]
 C2D6 CAP_P_RDL [54A4]
 C2E1 CAPN_402 [23A3]
 C2E2 CAPN_805 [25A4]
 C2E3 CAPN_402 [23A1]
 C2E4 CAPN_402 [12D3]
 C2E5 CAPN_402 [42C5]
 C2E6 CAPN_805 [42C5]
 C2E8 CAPN_805 [23A3]
 C2F1 CAP_P_RDL [55B2]
 C2F2 CAPN_402 [32D5]
 C2F3 CAP_P_RDL [55B2]
 C2G1 CAPN_402 [32C5]
 C2G2 CAP_P_RDL [46B2]
 C2G3 CAPN_805 [46B2]
 C2M2 CAPN_402 [44A1]
 C2M3 CAPN_402 [44A2]
 C2M4 CAPN_402 [44A3]
 C2M5 CAPN_805 [44D4]
 C2N1 CAPN_402 [37A1]
 C2N3 CAPN_402 [44A1]
 C2P1 CAPN_805 [38A2]
 C2P2 CAPN_402 [37B6]
 C2P3 CAPN_402 [37B6]
 C2P4 CAPN_603 [38A2]
 C2P5 CAPN_402 [37A1]
 C2P6 CAPN_402 [37A6]
 C2P7 CAPN_402 [27A8]
 C2P8 CAPN_805 [37A8]
 C2P9 CAPN_402 [38B2]
 C2P10 CAPN_805 [38C7]
 C2P11 CAPN_402 [38B2]
 C2P12 CAPN_402 [38B3]
 C2P13 CAPN_402 [38B3]
 C2P14 CAPN_402 [38B2]
 C2P15 CAPN_402 [38D2]
 C2P16 CAPN_402 [38D3]
 C2P17 CAPN_402 [38D2]
 C2P18 CAPN_402 [33C6]
 C2P20 CAPN_603 [38C2]
 C2P21 CAPN_402 [38D3]
 C2P22 CAPN_402 [38D4]
 C2P23 CAPN_402 [37B1]
 C2P24 CAPN_402 [37B1]
 C2P25 CAPN_402 [33C7]
 C2P26 CAPN_402 [38D7]
 C2P27 CAPN_603 [38D7]
 C2P28 CAPN_402 [38D3]
 C2P29 CAPN_402 [38D1]

C2P30 CAPN_402 [38D2]
 C2P31 CAPN_402 [38C6]
 C2P32 CAPN_402 [38C7]
 C2P33 CAPN_402 [38D1]
 C2P34 CAPN_603 [37A7]
 C2P35 CAPN_402 [37A7]
 C2P37 CAPN_402 [37B2]
 C2P38 CAPN_402 [37B2]
 C2P39 CAPN_603 [38C2]
 C2P40 CAPN_402 [35B6]
 C2P41 CAPN_402 [37B7]
 C2P42 CAPN_402 [37C6]
 C2P43 CAPN_402 [37C6]
 C2P44 CAPN_402 [37A7]
 C2P45 CAPN_805 [37B7]
 C2P46 CAPN_603 [37C7]
 C2P47 CAPN_603 [37C7]
 C2P48 CAPN_603 [37A7]
 C2P50 CAPN_402 [28D7]
 C2P51 CAPN_603 [34D6]
 C2P52 CAPN_402 [38A7]
 C2R1 CAPN_402 [28D8]
 C2R2 CAPN_402 [28D8]
 C2R3 CAPN_805 [37B8]
 C2R4 CAPN_603 [54A4]
 C2R5 CAPN_805 [37C8]
 C2R6 CAPN_805 [37A8]
 C2R7 CAPN_402 [26A3]
 C2R8 CAPN_402 [26A1]
 C2R9 CAPN_402 [23A7]
 C2R10 CAPN_402 [26A1]
 C2R11 CAPN_402 [42C4]
 C2R12 CAPN_402 [12C3]
 C2R13 CAPN_402 [26A5]
 C2T1 CAPN_402 [24A3]
 C2T2 CAPN_402 [25A7]
 C2T3 CAPN_402 [24A1]
 C2T4 CAPN_402 [32B6]
 C2T5 CAPN_603 [54A5]
 C2T6 CAPN_402 [26A4]
 C2T7 CAPN_805 [26B4]
 C2V1 CAPN_805 [43A3]
 C2V2 CAPN_402 [43A3]
 C3A1 CAPN_402 [44C6]
 C3A2 CAPN_402 [44C6]
 C3A3 CAPN_402 [44D6]
 C3A4 CAPN_402 [44C7]
 C3A5 CAPN_402 [44C7]
 C3A6 CAPN_402 [44D7]
 C3A7 CAPN_402 [44B7]
 C3A8 CAPN_402 [44B6]
 C3A9 CAPN_603 [43C3]
 C3B1 CAPN_402 [27B2]
 C3B2 CAPN_402 [27A2]
 C3B4 CAPN_402 [27A1]
 C3B6 CAPN_402 [27D8]
 C3B7 CAPN_402 [27D8]

C3B8	CAPN_402	[58B5]
C3B9	CAPN_603	[58B4]
C3B12	CAPN_402	[27A2]
C3C1	CAPN_805	[56A5]
C3C2	CAPN_805	[13A2]
C3C5	CAPN_805	[23A4]
C3C6	CAPN_805	[30C3]
C3D1	CAPN_402	[25A2]
C3D2	CAPN_402	[25A2]
C3D3	CAPN_402	[24A7]
C3D4	CAPN_402	[25A2]
C3D5	CAPN_402	[25A1]
C3D6	CAPN_402	[25A1]
C3E1	CAPN_402	[23A2]
C3E2	CAPN_402	[23A2]
C3E3	CAPN_402	[23A2]
C3E4	CAPN_402	[26A7]
C3E5	CAPN_402	[23A2]
C3E6	CAPN_402	[23A1]
C3E7	CAPN_402	[23A1]
C3E8	CAPN_402	[26A4]
C3F1	CAPN_402	[19A2]
C3F3	CAPN_402	[19A3]
C3F5	CAPN_402	[26A4]
C3F6	CAP_P_RDL	[55B2]
C3G3	CAPN_402	[32C5]
C3N1	CAPN_402	[32B4]
C3N2	CAPN_402	[32D6]
C3N3	CAPN_805	[30C2]
C3N6	CAPN_402	[27A7]
C3N10	CAPN_402	[28D7]
C3P1	CAPN_805	[31D2]
C3P3	CAPN_805	[38D8]
C3P4	CAPN_402	[28D8]
C3R1	CAPN_402	[26A2]
C3R2	CAPN_402	[26A2]
C3R3	CAPN_402	[25D4]
C3R4	CAPN_402	[26A2]
C3R5	CAPN_805	[15A6]
C3R6	CAPN_402	[26A1]
C3R7	CAPN_402	[26A2]
C3R8	CAPN_402	[13A1]
C3R9	CAPN_402	[13A2]
C3T1	CAPN_402	[24A3]
C3T2	CAPN_402	[24A2]
C3T3	CAPN_402	[24A2]
C3T4	CAPN_402	[24C4]
C3T5	CAPN_402	[24A2]
C3T6	CAPN_402	[24A1]
C3T7	CAPN_402	[24A2]
C3U1	CAPN_402	[20A2]
C3U2	CAPN_402	[20A3]
C3U3	CAPN_402	[32B6]
C3U4	CAPN_402	[26A4]
C3U5	CAPN_603	[55B1]
C3V5	CAPN_402	[46B2]
C3V6	CAPN_603	[55D2]

C3V7	CAPN_603	[55C4]
C3V8	CAPN_402	[55A6]
C4A1	CAPN_402	[32C5]
C4B3	CAPN_402	[28A6]
C4B4	CAPN_402	[28C2]
C4B10	CAPN_402	[28B2]
C4B11	CAPN_402	[28B2]
C4B12	CAPN_402	[28C2]
C4B13	CAPN_402	[27D6]
C4C6	CAPN_805	[56B4]
C4D1	CAPN_402	[13D3]
C4D2	CAPN_402	[13D3]
C4D3	CAPN_402	[13D3]
C4D4	CAPN_402	[16D6]
C4D5	CAPN_402	[16D6]
C4D6	CAPN_603	[16D7]
C4D7	CAPN_402	[13C3]
C4F1	CAPN_402	[19A1]
C4F2	CAPN_402	[20A7]
C4F3	CAPN_402	[19A1]
C4F4	CAPN_402	[21A2]
C4F5	CAPN_402	[21A2]
C4F6	CAPN_402	[19A1]
C4F7	CAPN_402	[19A2]
C4F8	CAPN_402	[21A2]
C4F9	CAPN_402	[19A2]
C4F10	CAPN_402	[21A3]
C4F11	CAPN_402	[19A2]
C4F12	CAPN_805	[19A4]
C4F13	CAPN_402	[32D3]
C4F14	CAPN_402	[26A3]
C4F15	CAPN_402	[26A3]
C4G1	CAPN_402	[55B1]
C4N1	CAPN_402	[32A7]
C4N3	CAPN_805	[31C8]
C4N4	CAPN_805	[31B7]
C4N5	CAPN_402	[31C7]
C4N6	CAPN_805	[31C7]
C4N7	CAPN_805	[31B6]
C4N8	CAPN_805	[30B7]
C4N9	CAPN_402	[31C7]
C4N10	CAPN_402	[31C6]
C4N11	CAPN_402	[31B6]
C4N12	CAPN_402	[31C6]
C4N13	CAPN_402	[31C6]
C4N14	CAPN_402	[31C6]
C4N15	CAPN_805	[30C8]
C4N16	CAPN_402	[30C7]
C4N17	CAPN_402	[30A4]
C4N18	CAPN_402	[30A8]
C4N19	CAPN_402	[30A7]
C4N20	CAPN_402	[30A7]
C4N21	CAPN_402	[31C1]
C4N22	CAPN_402	[31C2]
C4N23	CAPN_402	[30C7]
C4N24	CAPN_805	[30C7]
C4N25	CAPN_805	[30B7]

C4N26	CAPN_402	[30A2]
C4N27	CAPN_402	[30A3]
C4N28	CAPN_402	[30A7]
C4N29	CAPN_402	[30C7]
C4N30	CAPN_402	[31C3]
C4N31	CAPN_402	[30A5]
C4N32	CAPN_402	[31C3]
C4N33	CAPN_402	[31C2]
C4N34	CAPN_402	[30A4]
C4N35	CAPN_402	[30D6]
C4N36	CAPN_805	[30D7]
C4N37	CAPN_805	[30D7]
C4N40	CAPN_402	[32C7]
C4N41	CAPN_402	[31C3]
C4N42	CAPN_402	[30A6]
C4P1	CAPN_402	[30A2]
C4P2	CAPN_402	[28B7]
C4P3	CAPN_805	[31D3]
C4P4	CAPN_402	[31D3]
C4P5	CAPN_402	[30A4]
C4P6	CAPN_402	[30A4]
C4P7	CAPN_402	[31C2]
C4P8	CAPN_402	[30A6]
C4P9	CAPN_402	[30A2]
C4P11	CAPN_402	[30A3]
C4P13	CAPN_805	[30C2]
C4P14	CAPN_402	[43C4]
C4R3	CAPN_805	[14A6]
C4R4	CAPN_402	[16C6]
C4R5	CAPN_402	[16B6]
C4R6	CAPN_402	[16C6]
C4R7	CAPN_402	[16B6]
C4R8	CAPN_402	[16C5]
C4R9	CAPN_402	[18A5]
C4R10	CAPN_402	[15A7]
C4R11	CAPN_402	[18D7]
C4R12	CAPN_402	[15A2]
C4R13	CAPN_402	[18D5]
C4R14	CAPN_402	[18C8]
C4R15	CAPN_402	[15A2]
C4R16	CAPN_402	[18D6]
C4R17	CAPN_402	[18C7]
C4R18	CAPN_402	[18A8]
C4R19	CAPN_402	[15A1]
C4R20	CAPN_402	[18D8]
C4R21	CAPN_402	[18C6]
C4R22	CAPN_402	[18C5]
C4R23	CAPN_402	[15A6]
C4R24	CAPN_402	[18B5]
C4R25	CAPN_402	[15A8]
C4R26	CAPN_402	[13A1]
C4R27	CAPN_402	[12A7]
C4R28	CAPN_402	[18D5]
C4R29	CAPN_805	[18D1]
C4R30	CAPN_805	[18C1]
C4R31	CAPN_402	[15A2]
C4R32	CAPN_402	[15A5]

C4R33	CAPN_402	[12A6]
C4R34	CAPN_402	[18B7]
C4R35	CAPN_402	[18B6]
C4R36	CAPN_402	[18B7]
C4R37	CAPN_402	[18C8]
C4R38	CAPN_402	[15A6]
C4R39	CAPN_402	[18B8]
C4R40	CAPN_402	[18B5]
C4R41	CAPN_402	[18B6]
C4R42	CAPN_402	[18A7]
C4R43	CAPN_402	[18A5]
C4R44	CAPN_402	[18C5]
C4R45	CAPN_402	[12A6]
C4R46	CAPN_402	[18B6]
C4R47	CAPN_402	[18C7]
C4R48	CAPN_402	[15A5]
C4R49	CAPN_402	[18A8]
C4R50	CAPN_402	[15A1]
C4R51	CAPN_402	[15A5]
C4R54	CAPN_402	[18D4]
C4R55	CAPN_402	[18C7]
C4R56	CAPN_402	[18B4]
C4R57	CAPN_402	[18B4]
C4R58	CAPN_402	[18A4]
C4R59	CAPN_402	[18C4]
C4R60	CAPN_402	[12A5]
C4R61	CAPN_402	[15A2]
C4R62	CAPN_402	[18A5]
C4R63	CAPN_402	[18A6]
C4R64	CAPN_402	[15A3]
C4R65	CAPN_402	[12A5]
C4R66	CAPN_402	[15A6]
C4R67	CAPN_402	[18A6]
C4R68	CAPN_603	[16C7]
C4R69	CAPN_805	[18C1]
C4R70	CAPN_402	[12A7]
C4T1	CAPN_402	[18A7]
C4T2	CAPN_402	[18A6]
C4T3	CAPN_402	[18A8]
C4T4	CAPN_402	[18B4]
C4T5	CAPN_402	[18C4]
C4T6	CAPN_402	[18C4]
C4T7	CAPN_402	[15A2]
C4T8	CAPN_402	[18A4]
C4T11	CAPN_402	[18B8]
C4T12	CAPN_402	[15A5]
C4T13	CAPN_402	[12A5]
C4T14	CAPN_402	[15A5]
C4T15	CAPN_402	[18C8]
C4T16	CAPN_402	[18A7]
C4T17	CAPN_805	[18C1]
C4T18	CAPN_402	[18B5]
C4T19	CAPN_402	[18B5]
C4T20	CAPN_402	[18B7]
C4T21	CAPN_402	[18C6]
C4T22	CAPN_402	[12A6]
C4T23	CAPN_402	[18C5]

C4T24	CAPN_402	[18B5]
C4T25	CAPN_402	[18B8]
C4T26	CAPN_402	[18C6]
C4T27	CAPN_402	[14A6]
C4T28	CAPN_805	[15A2]
C4T29	CAPN_402	[14A6]
C4T30	CAPN_402	[16C6]
C4T31	CAPN_402	[14A2]
C4T32	CAPN_402	[14A5]
C4T33	CAPN_402	[14A2]
C4T34	CAPN_402	[14A2]
C4T35	CAPN_402	[14A6]
C4T36	CAPN_402	[15A4]
C4T37	CAPN_402	[16C6]
C4T38	CAPN_402	[15A1]
C4T39	CAPN_402	[14A1]
C4T40	CAPN_402	[14A8]
C4T41	CAPN_402	[14A5]
C4T42	CAPN_402	[14A5]
C4T43	CAPN_402	[14A5]
C4T44	CAPN_402	[14A5]
C4T45	CAPN_402	[14A7]
C4T46	CAPN_402	[14A3]
C4T47	CAPN_805	[14A2]
C4T48	CAPN_603	[16C7]
C4U1	CAPN_402	[20A1]
C4U2	CAPN_402	[20A1]
C4U3	CAPN_402	[22A2]
C4U4	CAPN_402	[22A2]
C4U5	CAPN_402	[20A1]
C4U6	CAPN_402	[20A2]
C4U7	CAPN_402	[22A2]
C4U8	CAPN_402	[20A2]
C4U9	CAPN_402	[19A7]
C4U10	CAPN_402	[22A3]
C4U11	CAPN_402	[20A2]
C4U12	CAPN_402	[26A3]
C4V1	CAPN_402	[55B8]
C4V6	CAPN_402	[46D2]
C4V7	CAPN_603	[55D3]
C4V8	CAPN_603	[55C6]
C4V9	CAPN_402	[55B4]
C4V10	CAPN_402	[55B3]
C4V11	CAPN_402	[55B2]
C4V12	CAPN_402	[55B7]
C4V13	CAPN_402	[55B6]
C4V14	CAPN_402	[55B5]
C4V15	CAPN_603	[55C6]
C5B1	CAPN_603	[56C7]
C5B2	CAP_P_RDL	[56C6]
C5B3	CAPN_805	[56C8]
C5B4	CAP_P_RDL	[56B6]
C5B6	CAPN_603	[56B6]
C5B7	CAP_P_RDL	[49B3]
C5C3	CAPN_402	[13A3]
C5C5	CAPN_805	[56B1]
C5C6	CAPN_603	[54C3]

C5C8	CAP_P_8X8	[50A1]
C5C9	CAP_P_8X8	[50A1]
C5D2	CAPN_805	[18D3]
C5D3	CAPN_805	[18C2]
C5D4	CAPN_805	[18C2]
C5D5	CAPN_805	[18B2]
C5D6	CAPN_805	[18B2]
C5E1	CAPN_402	[14A4]
C5F1	CAPN_402	[22A7]
C5F2	CAPN_402	[21A1]
C5F3	CAPN_402	[21A1]
C5F4	CAPN_402	[21A1]
C5F5	CAPN_402	[21A2]
C5F6	CAPN_805	[21A4]
C5F8	CAP_P_RDL	[21A4]
C5G1	CAPN_402	[32C3]
C5G3	CAPN_402	[32C5]
C5G4	CAP_P_RDL	[46D2]
C5G5	CAPN_402	[32C4]
C5G6	CAPN_805	[46D2]
C5N1	CAPN_402	[32A7]
C5N2	CAPN_402	[32B4]
C5N3	CAPN_805	[56B8]
C5P1	CAPN_402	[56B3]
C5R1	CAPN_805	[18B3]
C5R2	CAPN_805	[18B3]
C5R3	CAPN_805	[18A3]
C5R4	CAPN_805	[18C3]
C5R5	CAPN_805	[18C3]
C5R6	CAPN_805	[18A3]
C5R7	CAPN_402	[16C5]
C5R8	CAPN_402	[18B5]
C5R9	CAPN_402	[18A2]
C5R10	CAPN_402	[18C5]
C5R11	CAPN_805	[18A3]
C5R12	CAPN_402	[18C5]
C5R13	CAPN_402	[16A6]
C5R14	CAPN_402	[18A5]
C5R15	CAPN_402	[16A6]
C5R16	CAPN_402	[18C5]
C5R17	CAPN_402	[18A5]
C5R18	CAPN_402	[12A6]
C5R19	CAPN_603	[16A7]
C5R20	CAPN_805	[18B3]
C5T1	CAPN_402	[14A1]
C5T2	CAPN_402	[14A1]
C5T3	CAPN_402	[14A2]
C5T4	CAPN_402	[14A2]
C5U1	CAPN_402	[22A1]
C5U2	CAPN_402	[22A1]
C5U3	CAPN_402	[22A1]
C5U4	CAPN_402	[22A2]
C5U5	CAPN_402	[21A7]
C5V1	CAPN_402	[32C6]
C6B1	CAPN_402	[32C5]
C6B2	CAPN_1206	[54D5]
C6B3	CAP_P_RDL	[50B3]

C6B5	CAPN_1206	[50B2]
C6C1	CAP_P_RDL	[50A2]
C6C2	CAP_P_RDL	[50A2]
C6C3	CAP_P_RDL	[50A3]
C6D1	CAPN_402	[6C7]
C6D4	CAPN_603	[6C6]
C6E1	CAPN_805	[18C2]
C6E2	CAPN_805	[18C3]
C6F1	CAPN_402	[4A2]
C6F3	CAP_P_RDL	[55D8]
C6G2	CAPN_402	[49D6]
C6G3	CAPN_402	[49C6]
C6G4	CAPN_402	[49C6]
C6G5	CAP_P_RDL	[49D6]
C6N1	CAPN_402	[32B7]
C6N2	CAPN_1206	[50B2]
C6P1	CAPN_805	[56A4]
C6R1	CAPN_402	[56A3]
C6R2	CAPN_402	[6B7]
C6R3	CAPN_402	[6B7]
C6R4	CAPN_603	[6B6]
C6R5	CAPN_603	[6B6]
C6R6	CAPN_402	[5A4]
C6R7	CAPN_805	[9D3]
C6R10	CAPN_805	[9C3]
C6R12	CAPN_402	[11A6]
C6R13	CAPN_402	[11A7]
C6R14	CAPN_402	[5A6]
C6R15	CAPN_402	[5A7]
C6R16	CAPN_402	[10B6]
C6R17	CAPN_402	[10C7]
C6R18	CAPN_402	[5A6]
C6R19	CAPN_402	[10B6]
C6R20	CAPN_402	[10B5]
C6R21	CAPN_402	[10A5]
C6R23	CAPN_402	[10B5]
C6R24	CAPN_402	[11D5]
C6R25	CAPN_402	[5A6]
C6R26	CAPN_402	[11C7]
C6R28	CAPN_402	[10C7]
C6R29	CAPN_402	[10C7]
C6R30	CAPN_402	[11B3]
C6R32	CAPN_402	[10D5]
C6R35	CAPN_402	[10A6]
C6R36	CAPN_402	[10C5]
C6R37	CAPN_402	[5A5]
C6R39	CAPN_402	[10B7]
C6R41	CAPN_402	[11A7]
C6R42	CAPN_402	[10B7]
C6R44	CAPN_402	[10D5]
C6R47	CAPN_805	[18D2]
C6T1	CAPN_805	[9A5]
C6T2	CAPN_402	[10D3]
C6T3	CAPN_402	[11B7]
C6T4	CAPN_402	[11D3]
C6T6	CAPN_402	[10C5]
C6T7	CAPN_402	[5A5]

C6T9	CAPN_402	[11B7]
C6T10	CAPN_402	[10D4]
C6T11	CAPN_402	[11C3]
C6T12	CAPN_402	[59C5]
C6T13	CAPN_402	[11C6]
C6T14	CAPN_402	[11C5]
C6T16	CAPN_402	[11C7]
C6T17	CAPN_402	[11D4]
C6T18	CAPN_402	[11C4]
C6T19	CAPN_402	[5A5]
C6T21	CAPN_402	[11A6]
C6T22	CAPN_402	[11B5]
C6T24	CAPN_402	[11D6]
C6T25	CAPN_402	[10B4]
C6T26	CAPN_402	[10A5]
C6T27	CAPN_402	[5A5]
C6T31	CAPN_402	[59C4]
C6T32	CAPN_402	[5A4]
C6T33	CAPN_402	[5A4]
C6T34	CAPN_402	[59C5]
C6T35	CAPN_402	[59C5]
C6T36	CAPN_402	[59C5]
C6U1	CAPN_603	[55B8]
C6U2	CAPN_603	[55D7]
C6V10	CAPN_402	[49B6]
C6V11	CAPN_402	[49B6]
C6V15	CAPN_402	[49B7]
C7B1	CAPN_402	[32D5]
C7B2	CAPN_1206	[54C5]
C7B3	CAP_P_RDL	[50B3]
C7B4	CAPN_1206	[50B1]
C7C1	CAP_P_RDL	[50A3]
C7C2	CAP_P_RDL	[50A4]
C7C3	CAP_P_RDL	[50A2]
C7D1	CAPN_603	[6A7]
C7D2	CAPN_603	[6A6]
C7D3	CAPN_805	[9C5]
C7D4	CAPN_805	[9C4]
C7D5	CAPN_805	[9B5]
C7D7	CAPN_805	[9B4]
C7D8	CAPN_805	[9C4]
C7D11	CAPN_805	[9B5]
C7D12	CAPN_805	[9C5]
C7D18	CAPN_805	[9C4]
C7D19	CAPN_805	[9C5]
C7D23	CAPN_402	[58A5]
C7E1	CAPN_805	[9C5]
C7E2	CAPN_805	[9C5]
C7E5	CAPN_805	[9B5]
C7E6	CAPN_805	[9D5]
C7E9	CAPN_805	[9B6]
C7E10	CAPN_805	[9B6]
C7F1	CAP_P_RDL	[55D2]
C7F3	CAP_P_RDL	[55B8]
C7F4	CAP_P_RDL	[57C2]
C7F5	CAPN_1206	[57C1]
C7G2	CAPN_402	[32D7]

C7G3 CAPN_1206 [57C2]
 C7G4 CAPN_1206 [57C2]
 C7G5 CAPN_603 [57C1]
 C7G16 CAPN_402 [32C4]
 C7N1 CAPN_402 [32B7]
 C7N2 CAPN_402 [32A4]
 C7N3 CAPN_1206 [50B1]
 C7P1 CAPN_805 [56A1]
 C7R1 CAPN_402 [6C7]
 C7R2 CAPN_805 [9C6]
 C7R3 CAPN_805 [9D5]
 C7R4 CAPN_805 [9A4]
 C7R5 CAPN_805 [9B4]
 C7R7 CAPN_603 [6C6]
 C7R14 CAPN_402 [11C5]
 C7R19 CAPN_402 [10C6]
 C7R20 CAPN_402 [11C6]
 C7R21 CAPN_402 [11B7]
 C7R22 CAPN_402 [10D6]
 C7R23 CAPN_805 [9A5]
 C7R24 CAPN_805 [9A5]
 C7R25 CAPN_805 [9A4]
 C7R26 CAPN_805 [9B6]
 C7R27 CAPN_805 [9D4]
 C7R28 CAPN_805 [9C3]
 C7R29 CAPN_805 [9C3]
 C7R30 CAPN_805 [9A5]
 C7R31 CAPN_402 [11D7]
 C7R32 CAPN_402 [11A5]
 C7R33 CAPN_402 [11A5]
 C7R34 CAPN_402 [10C6]
 C7R35 CAPN_402 [10C6]
 C7R39 CAPN_402 [11B6]
 C7R40 CAPN_402 [11B6]
 C7R41 CAPN_402 [11B6]
 C7R42 CAPN_402 [11C6]
 C7R43 CAPN_402 [10B6]
 C7R44 CAPN_402 [10D7]
 C7R48 CAPN_402 [10C4]
 C7R49 CAPN_402 [10D7]
 C7R50 CAPN_402 [10C5]
 C7R51 CAPN_402 [10D5]
 C7R52 CAPN_402 [10D5]
 C7R56 CAPN_402 [11C7]
 C7R57 CAPN_402 [10B5]
 C7R58 CAPN_402 [10B5]
 C7R59 CAPN_402 [10B5]
 C7R60 CAPN_402 [10A5]
 C7R61 CAPN_402 [10A6]
 C7R65 CAPN_402 [11A3]
 C7R66 CAPN_402 [11D3]
 C7R67 CAPN_402 [10A7]
 C7R68 CAPN_402 [10C5]
 C7R69 CAPN_402 [10B5]
 C7R74 CAPN_402 [11B3]
 C7R75 CAPN_402 [11B5]
 C7R76 CAPN_402 [10B7]

C7R81 CAPN_402 [10C5]
 C7R82 CAPN_402 [11B3]
 C7R83 CAPN_402 [11B4]
 C7R89 CAPN_402 [10B4]
 C7R90 CAPN_805 [9C5]
 C7R91 CAPN_805 [9B4]
 C7R95 CAPN_402 [11D4]
 C7R99 CAPN_402 [10A4]
 C7R100 CAPN_402 [10A4]
 C7R101 CAPN_402 [11C4]
 C7R102 CAPN_402 [10C5]
 C7R106 CAPN_402 [11C5]
 C7R110 CAPN_402 [11D5]
 C7R111 CAPN_402 [10C3]
 C7R112 CAPN_603 [4D6]
 C7R113 CAPN_603 [4D6]
 C7R114 CAPN_402 [6D5]
 C7R115 CAPN_402 [6D5]
 C7R116 CAPN_402 [6D5]
 C7R119 CAPN_805 [9C5]
 C7R120 CAPN_805 [9B5]
 C7R121 CAPN_805 [9B5]
 C7T1 CAPN_805 [9A6]
 C7T2 CAPN_402 [10A5]
 C7T3 CAPN_402 [10A7]
 C7T4 CAPN_805 [9B3]
 C7T5 CAPN_805 [9B4]
 C7T6 CAPN_805 [9A6]
 C7T7 CAPN_402 [11D2]
 C7T8 CAPN_402 [11C2]
 C7T9 CAPN_402 [10D6]
 C7T10 CAPN_402 [10C3]
 C7T11 CAPN_402 [11B6]
 C7T12 CAPN_402 [11C2]
 C7T13 CAPN_402 [11C2]
 C7T14 CAPN_402 [11D2]
 C7T15 CAPN_402 [11C3]
 C7T16 CAPN_402 [11B2]
 C7T17 CAPN_402 [11B2]
 C7T18 CAPN_402 [11B2]
 C7T19 CAPN_402 [11A2]
 C7T20 CAPN_402 [11A2]
 C7T21 CAPN_402 [10D3]
 C7T22 CAPN_402 [10D4]
 C7T23 CAPN_402 [11A3]
 C7T24 CAPN_402 [11C3]
 C7T25 CAPN_402 [11D6]
 C7T26 CAPN_402 [11A4]
 C7T27 CAPN_402 [10C4]
 C7T28 CAPN_402 [11C5]
 C7T29 CAPN_402 [11D2]
 C7T30 CAPN_402 [11D2]
 C7T31 CAPN_402 [11C2]
 C7T32 CAPN_805 [9B6]
 C7T33 CAPN_805 [9C6]
 C7T37 CAPN_402 [10B4]
 C7T38 CAPN_402 [11D5]

C7T39 CAPN_402 [11B4]
 C7T40 CAPN_402 [11B5]
 C7T41 CAPN_402 [11B5]
 C7T46 CAPN_402 [11A5]
 C7T47 CAPN_402 [11A5]
 C7T48 CAPN_402 [11A4]
 C7T49 CAPN_402 [11B5]
 C7T50 CAPN_402 [11C5]
 C7T51 CAPN_402 [10C4]
 C7T54 CAPN_402 [11D7]
 C7T55 CAPN_402 [11B4]
 C7T56 CAPN_402 [11C5]
 C7T57 CAPN_402 [11C4]
 C7T58 CAPN_402 [11D5]
 C7T83 CAPN_805 [9B5]
 C7T84 CAPN_805 [9B5]
 C7T90 CAPN_402 [59C5]
 C7T91 CAPN_402 [59C4]
 C7T92 CAPN_402 [59C5]
 C7T93 CAPN_805 [9C6]
 C7T94 CAPN_805 [9D6]
 C7T98 CAPN_603 [56C2]
 C7T99 CAPN_603 [56C1]
 C7T100 CAPN_603 [56D3]
 C7T102 CAPN_805 [57C1]
 C7T103 CAPN_805 [57C1]
 C7U5 CAPN_603 [57C6]
 C7U6 CAPN_402 [57C6]
 C7U7 CAPN_402 [57A6]
 C7U8 CAPN_402 [57B6]
 C7U9 CAPN_603 [57C4]
 C7U10 CAPN_402 [57A6]
 C7U11 CAPN_402 [57A5]
 C7V2 CAPN_603 [57C2]
 C8A1 CAPN_402 [49C3]
 C8A2 CAPN_402 [49C2]
 C8B1 CAP_P_RDL [49B3]
 C8B2 CAPN_1206 [50B4]
 C8B3 CAPN_603 [53D2]
 C8B4 CAPN_1206 [50B2]
 C8B6 CAPN_603 [54B3]
 C8B7 CAPN_402 [53A7]
 C8B8 CAPN_603 [53A7]
 C8B9 CAPN_805 [53D5]
 C8C1 CAP_P_RDL [50A5]
 C8C2 CAP_P_RDL [50A8]
 C8D1 CAP_P_RDL [50A6]
 C8D4 CAP_P_RDL [50A5]
 C8E1 CAP_P_RDL [50A7]
 C8E2 CAP_P_RDL [50A6]
 C8E3 CAP_P_RDL [50A8]
 C8F1 CAP_P_RDL [50A7]
 C8F2 CAPN_603 [57C4]
 C8T32 CAPN_402 [51A5]
 C8G4 CAPN_1206 [57C3]
 C8G5 CAPN_1206 [51D6]
 C8G6 CAPN_1206 [51D5]

C8N1 CAPN_603 [53C2]
 C8N3 CAPN_805 [53D6]
 C8N4 CAPN_402 [53B5]
 C8N5 CAPN_603 [53C7]
 C8P1 CAPN_603 [53C8]
 C8P2 CAPN_402 [53C7]
 C8P3 CAPN_603 [53B7]
 C8P4 CAPN_603 [53A6]
 C8P5 CAPN_402 [58A3]
 C8U1 CAPN_603 [51B3]
 C8U2 CAPN_402 [51B2]
 C8U3 CAPN_603 [51B5]
 C8U4 CAPN_402 [51C5]
 C8U5 CAPN_402 [57B3]
 C8U6 CAPN_402 [51A6]
 C8U7 CAPN_603 [51A7]
 C8U8 CAPN_402 [51A5]
 C8U9 CAPN_402 [57C6]
 C8U10 CAPN_402 [51B4]
 C8V1 CAPN_603 [51B6]
 C8V15 CAPN_603 [51D6]
 C9A1 CAPN_603 [49D3]
 C9A2 CAPN_603 [49D2]
 C9A3 CAPN_402 [58C2]
 C9A4 CAPN_402 [49B2]
 C9A5 CAPN_603 [49D3]
 C9A6 CAPN_603 [49D3]
 C9B1 CAP_P_RDL [49D4]
 C9B2 CAPN_1206 [50B8]
 C9B3 CAPN_603 [53C2]
 C9B4 CAPN_1206 [50B6]
 C9C1 CAP_P_RDL [50B7]
 C9C2 CAPN_603 [53B3]
 C9C3 CAPN_1206 [50B5]
 C9C4 CAP_P_RDL [50B7]
 C9C7 CAPN_402 [32B7]
 C9C8 CAPN_402 [62B3]
 C9C9 CAPN_603 [62B3]
 C9C10 CAPN_805 [62B3]
 C9C11 CAPN_603 [62B6]
 C9C12 CAPN_805 [62C7]
 C9D2 CAP_P_RDL [50B6]
 C9D4 CAPN_1206 [52C3]
 C9D5 CAPN_805 [62C3]
 C9D6 CAPN_603 [62C6]
 C9D7 CAPN_805 [62C7]
 C9D8 CAPN_805 [62C7]
 C9D9 CAPN_805 [62C3]
 C9D10 CAPN_603 [62C3]
 C9D11 CAPN_402 [62C3]
 C9E1 CAPN_1206 [52C2]
 C9E2 CAPN_402 [32C7]
 C9E3 CAP_P_RDL [50B7]
 C9E4 CAPN_603 [52B1]
 C9F1 CAPN_1206 [52A2]
 C9F2 CAPN_402 [32C7]
 C9F3 CAPN_603 [52A1]

C9F4	CAPN_1206	[52A3]	
C9G1	CAPN_402	[46D6]	
C9G2	CAP_P_RDL	[46D6]	
C9G3	CAP_P_RDL	[46B6]	
C9G4	CAPN_402	[46B6]	
C9G5	CAPN_805	[46D6]	
C9G6	CAPN_805	[46B7]	
C9N1	CAPN_402	[32B4]	
C9P1	CAPN_603	[53C8]	
C9T1	CAPN_805	[52C4]	
C9T2	CAPN_805	[52C5]	
C9T3	CAPN_805	[52C7]	
C9U1	CAPN_805	[52A4]	
C9U2	CAPN_805	[52B5]	
C9U3	CAPN_805	[52A7]	
CM2A1	CMCHOKE_SM	[29D6]	
CM2A2	CMCHOKE_SM	[29C6]	
CM3A1	CMCHOKE_SM	[29B6]	
CM3A2	CMCHOKE_SM	[29A6]	
CR1D1	MBT3904DUAL_SOT	[47B6]	
CR1D2	DIOSOT23S_SOT23S	[48A2]	
CR1D3	DIOSOT23S_SOT23S	[48A1]	
CR2A1	MBT3904DUAL_SOT	[44B5]	
CR2M2	MBT3904DUAL_SOT	[41A3]	
CR3A1	BAV99DUAL_SOT363	[44C8]	44B8]
CR3A2	BAV99DUAL_SOT363	[44D8]	44C8]
CR3M1	BAV99DUAL_SOT363	[29B4]	29B3]
CR3M2	BAV99DUAL_SOT363	[44A7]	44A6]
CR6T1	MBT3904DUAL_SOT	[56C4]	
CR7V2	MBR0520L_SOD123	[57B4]	
D1A1	DIOSOT23S_SOT23S	[45C6]	
D1A2	DIOSOT23S_SOT23S	[45D6]	
D1B1	DIOSOT23S_SOT23S	[45B6]	
D1E1	DIOSOT23S_SOT23S	[48B6]	
D1E2	DIOSOT23S_SOT23S	[48C6]	
D1E3	DIOSOT23S_SOT23S	[48C5]	
D1E4	DIOSOT23S_SOT23S	[48D5]	
D1F1	LED_SM	[34A3]	
D2A1	DIOSOT23S_SOT23S	[44D4]	
D3A1	DIODE_SOT23	[43C3]	
D3V1	BAT54A_SOT23S	[55D6]	
D5B1	DIODE_SMA	[56B7]	
D5N1	DIODE_SOD123	[56B8]	
D5N2	DIODE_SOD123	[56B8]	
D8B1	ZENER_SOD123	[53C2]	
D8B2	DIODE_SOT23	[53D3]	
D8B3	DIOSOT23S_SOT23S	[53D2]	
D8B4	LED_SM	[58B2]	
D9E1	DIODE_SOT23	[52C6]	
D9F1	DIODE_SOT23	[52B6]	
D9G1	DIOSOT23S_SOT23S	[46C6]	
D9G2	DIOSOT23S_SOT23S	[46C6]	
D9V1	DIOSOT23S_SOT23S	[46A6]	
D9V2	DIOSOT23S_SOT23S	[46A6]	
DB1F1	DBPAD_TP	[34A7]	
DB1N1	DBPAD_TP	[40C5]	
DB1N3	DBPAD_TP	[39B5]	

DB1N4	DBPAD_TP	[39C7]	
DB1N5	DBPAD_TP	[33D6]	
DB1P1	DBPAD_TP	[33B2]	
DB1P2	DBPAD_TP	[33B2]	
DB2B1	DBPAD_TP	[34B3]	
DB2N3	DBPAD_TP	[33B2]	
DB2N4	DBPAD_TP	[33B2]	
DB2N5	DBPAD_TP	[33B2]	
DB2N6	DBPAD_TP	[33B2]	
DB2N7	DBPAD_TP	[33B2]	
DB2N8	DBPAD_TP	[33C6]	
DB2N9	DBPAD_TP	[33B2]	
DB2N10	DBPAD_TP	[33B2]	
DB2N11	DBPAD_TP	[33B2]	
DB2N12	DBPAD_TP	[33B2]	
DB2P1	DBPAD_TP	[33C2]	
DB2P2	DBPAD_TP	[33C2]	
DB2P3	DBPAD_TP	[33C2]	
DB2P4	DBPAD_TP	[33B2]	
DB2P5	DBPAD_TP	[33B2]	
DB2P6	DBPAD_TP	[33B2]	
DB2P7	DBPAD_TP	[33B2]	
DB2P8	DBPAD_TP	[34A6]	
DB2P9	DBPAD_TP	[34A6]	
DB2P15	DBPAD_TP	[33D6]	
DB3A1	DBPAD_TP	[29C3]	
DB3F1	DBPAD_TP	[55C1]	
DB4D1	DBPAD_TP	[13C3]	
DB4P1	DBPAD_TP	[28A2]	
DB4P2	DBPAD_TP	[28A2]	
DB4P3	DBPAD_TP	[28A2]	
DB4P4	DBPAD_TP	[28A2]	
DB4P5	DBPAD_TP	[28B5]	
DB6E1	DBPAD_TP	[47C4]	
DB6E2	DBPAD_TP	[47C4]	
DB6E3	DBPAD_TP	[47C4]	
DB6E4	DBPAD_TP	[47C4]	
DB6G1	DBPAD_TP	[55C8]	
DB7R1	DBPAD_TP	[4C1]	
DB7R2	DBPAD_TP	[4C6]	
DB7U1	DBPAD_TP	[57B4]	
DB7U2	DBPAD_TP	[57C7]	
DB8F4	DBPAD_TP	[57C5]	
DB8M1	DBPAD_TP	[49D2]	
DB8M2	DBPAD_TP	[49D2]	
DB8M3	DBPAD_TP	[49D2]	
DB8N1	DBPAD_TP	[49C3]	
DB8P1	DBPAD_TP	[50B5]	
DB8P2	DBPAD_TP	[50B5]	
DB8U1	DBPAD_TP	[57D6]	
DB8U2	DBPAD_TP	[57C6]	
DB8U3	DBPAD_TP	[57B4]	
DB8U4	DBPAD_TP	[51C5]	
DB9C1	DBPAD_TP	[62B1]	
DB9C2	DBPAD_TP	[62C2]	
EG1A1	ESDGUARD_603	[45C4]	
EG1A2	ESDGUARD_603	[45C5]	

EG1E1	ESDGUARD_603	[48C3]	
EG1E2	ESDGUARD_603	[48C4]	
EG1E3	ESDGUARD_603	[48C4]	
EG1E4	ESDGUARD_603	[48C5]	
EG2A1	ESDGUARD_402	[29D6]	
EG2A2	ESDGUARD_402	[29D6]	
EG2A3	ESDGUARD_402	[29C6]	
EG2A4	ESDGUARD_402	[29C6]	
EG2B1	ESDGUARD_603	[41B5]	
EG2B2	ESDGUARD_603	[41C5]	
EG2G1	ESDGUARD_603	[46B1]	
EG3A1	ESDGUARD_402	[29B5]	
EG3A2	ESDGUARD_402	[29B6]	
EG3A3	ESDGUARD_402	[29A5]	
EG3A4	ESDGUARD_402	[29A6]	
EG3G1	ESDGUARD_603	[46B2]	
EG3M1	ESDGUARD_603	[29B2]	
EG3M2	ESDGUARD_402	[29B4]	
EG3M3	ESDGUARD_402	[29B3]	
EG4G1	ESDGUARD_603	[46C2]	
EG4G2	ESDGUARD_603	[46C2]	
EG9G1	ESDGUARD_603	[46C5]	
EG9G2	ESDGUARD_603	[46D5]	
EG9V1	ESDGUARD_603	[46A5]	
EG9V2	ESDGUARD_603	[46A5]	
FB1B1	FERRITE_603	[39A6]	
FB1N1	FERRITE_603	[40C5]	
FB1P1	FERRITE_603	[38B7]	
FB1P2	FERRITE_603	[38C7]	
FB1P3	FERRITE_603	[38A7]	
FB1P4	FERRITE_603	[38B7]	
FB2B1	FERRITE_603	[41B3]	
FB2B2	FERRITE_603	[41D3]	
FB2P1	FERRITE_603	[37A7]	
FB2P2	FERRITE_603	[38D7]	
FB2P3	FERRITE_603	[37C7]	
FB2P4	FERRITE_603	[37C7]	
FB2P5	FERRITE_603	[37A7]	
FB2R1	FERRITE_603	[37B7]	
FB4D1	FERRITE_603	[16D7]	
FB4N5	FERRITE_603	[30D7]	
FB4N6	FERRITE_603	[31C7]	
FB4N7	FERRITE_603	[31B6]	
FB4N8	FERRITE_603	[30C7]	
FB4P1	FERRITE_603	[31D2]	
FB4R1	FERRITE_603	[16C7]	
FB4T1	FERRITE_603	[16C7]	
FB5G1	FERRITE_603	[46D2]	
FB5R1	FERRITE_603	[16B7]	
FB6D1	FERRITE_603	[6C7]	
FB6R1	FERRITE_603	[6B7]	
FB6R2	FERRITE_603	[6B7]	
FB7D1	FERRITE_603	[6A7]	
FB7R1	FERRITE_603	[6D7]	
FT1N1	FTPAD_TP	[33A2]	
FT1N2	FTPAD_TP	[45D3]	
FT1P1	FTPAD_TP	[27B1]	

FT1P2	FTPAD_TP	[27B1]	
FT1R1	FTPAD_TP	[47A8]	
FT1R2	FTPAD_TP	[47B3]	
FT1R3	FTPAD_TP	[42C7]	
FT1R4	FTPAD_TP	[42C7]	
FT1R5	FTPAD_TP	[42C7]	
FT1T1	FTPAD_TP	[42C4]	
FT1U1	FTPAD_TP	[56D4]	
FT1U2	FTPAD_TP	[34A7]	
FT1V1	FTPAD_TP	[46A1]	
FT2M1	FTPAD_TP	[41D6]	
FT2M2	FTPAD_TP	[29D4]	
FT2M3	FTPAD_TP	[29D4]	
FT2M4	FTPAD_TP	[29D4]	
FT2M5	FTPAD_TP	[29D4]	
FT2N1	FTPAD_TP	[41D7]	
FT2N2	FTPAD_TP	[41C8]	
FT2N3	FTPAD_TP	[27D3]	
FT2N4	FTPAD_TP	[27B1]	
FT2N5	FTPAD_TP	[34C8]	
FT2N6	FTPAD_TP	[29B3]	
FT2P1	FTPAD_TP	[41B6]	
FT2P2	FTPAD_TP	[27A1]	
FT2P3	FTPAD_TP	[53A2]	
FT2P4	FTPAD_TP	[27C8]	
FT2P5	FTPAD_TP	[34B1]	
FT2P6	FTPAD_TP	[53B2]	
FT2P7	FTPAD_TP	[27D7]	
FT2P10	FTPAD_TP	[34C6]	
FT2P11	FTPAD_TP	[4D8]	
FT2P12	FTPAD_TP	[4D8]	
FT2P13	FTPAD_TP	[13D4]	
FT2P14	FTPAD_TP	[13D8]	
FT2P15	FTPAD_TP	[34C8]	
FT2P16	FTPAD_TP	[51C2]	
FT2P17	FTPAD_TP	[51C7]	
FT2P18	FTPAD_TP	[55A7]	
FT2P19	FTPAD_TP	[55A3]	
FT2P20	FTPAD_TP	[35C6]	
FT2P21	FTPAD_TP	[35C6]	
FT2P22	FTPAD_TP	[35C6]	
FT2P23	FTPAD_TP	[35C6]	
FT2P24	FTPAD_TP	[34C8]	
FT2P25	FTPAD_TP	[34A7]	
FT2P26	FTPAD_TP	[56A5]	
FT2R2	FTPAD_TP	[27A1]	
FT2R3	FTPAD_TP	[42C7]	
FT2R4	FTPAD_TP	[42C7]	
FT2R5	FTPAD_TP	[42C7]	
FT2R6	FTPAD_TP	[42C7]	
FT2R7	FTPAD_TP	[42C7]	
FT2R8	FTPAD_TP	[54A4]	
FT2U1	FTPAD_TP	[55C1]	
FT3M1	FTPAD_TP	[29D4]	
FT3M2	FTPAD_TP	[29D4]	
FT3M3	FTPAD_TP	[29D4]	
FT3M4	FTPAD_TP	[29D4]	

FT3P1	FTPAD_TP	[27C1]
FT3P2	FTPAD_TP	[27C1]
FT3P3	FTPAD_TP	[34A7]
FT3P4	FTPAD_TP	[27D3]
FT4N1	FTPAD_TP	[28A6]
FT4N2	FTPAD_TP	[29C3]
FT4N4	FTPAD_TP	[28A6]
FT4N5	FTPAD_TP	[27B4]
FT4P1	FTPAD_TP	[27D7]
FT4P2	FTPAD_TP	[27B1]
FT4P3	FTPAD_TP	[27B1]
FT4P4	FTPAD_TP	[27D3]
FT5N1	FTPAD_TP	[56C6]
FT5N2	FTPAD_TP	[56B5]
FT5R1	FTPAD_TP	[56C1]
FT5R2	FTPAD_TP	[50A2]
FT6U1	FTPAD_TP	[47C4]
FT6U2	FTPAD_TP	[47C4]
FT6U3	FTPAD_TP	[47C4]
FT6U4	FTPAD_TP	[47C4]
FT6U5	FTPAD_TP	[47C4]
FT6U6	FTPAD_TP	[47C4]
FT6U7	FTPAD_TP	[47C4]
FT6U8	FTPAD_TP	[47C4]
FT6U9	FTPAD_TP	[47D5]
FT6U10	FTPAD_TP	[47D5]
FT6U11	FTPAD_TP	[47D5]
FT6V1	FTPAD_TP	[55C8]
FT7R1	FTPAD_TP	[4A7]
FT7R2	FTPAD_TP	[4A7]
FT7R3	FTPAD_TP	[56A1]
FT7R4	FTPAD_TP	[4A7]
FT7R5	FTPAD_TP	[4A7]
FT7R6	FTPAD_TP	[4A7]
FT7R7	FTPAD_TP	[58A5]
FT7T1	FTPAD_TP	[4B3]
FT7T2	FTPAD_TP	[4B3]
FT7T3	FTPAD_TP	[4B2]
FT7T4	FTPAD_TP	[4B2]
FT7T5	FTPAD_TP	[4B2]
FT7T6	FTPAD_TP	[56D1]
FT7T7	FTPAD_TP	[4B3]
FT7T8	FTPAD_TP	[56C6]
FT7T9	FTPAD_TP	[50A5]
FT7U3	FTPAD_TP	[57C1]
FT7U4	FTPAD_TP	[50A4]
FT8N1	FTPAD_TP	[49C3]
FT8P1	FTPAD_TP	[53D7]
FT8P2	FTPAD_TP	[53D7]
FT8U1	FTPAD_TP	[51B5]
FT8U2	FTPAD_TP	[51B5]
FT9C1	FTPAD_TP	[62C7]
FT9C2	FTPAD_TP	[62B6]
FT9C3A	FTPAD_TP	[62B2]
FT9D1	FTPAD_TP	[62C6]
FT9D2A	FTPAD_TP	[62C2]
FT9N1	FTPAD_TP	[49D3]

J1A1	XENONRJ45USB_TH	[45B2]
J1C1	1X7SATA_TH	[48A7]
J1D1	2X6HDR2_TH	[48A2]
J1D2	2X5HDR10_TH	[58D7]
J1E1	XENONHDD_TH	[48C2]
J2A1	HDMI_1X19HDR	[29C1]
J2B1	2X7HDR14_TH	[58C5]
J2D1	2X3HDR_TH	[33A6]
J2D2	2X4HDR_TH	[13A8]
J3A1	XENONAVIP_TH	[44C2]
J3A2	1X3HDR_TH	[43C2]
J4F1	1X3HDR_TH	[61B5]
J4G1	1X2HDR_TH	[61B4]
J4G2	XENONMU_TH	[46C1]
J5C1	2X3HDR_TH	[27A6]
J5C2	2X3HDR_TH	[13A5]
J6G1	XENONRF_TH	[49B5]
J8B1	1X8HDR_TH	[61C4]
J8C1	2X5HDR_TH	[58A3]
J9A1	XENONPWR_TH	[49C1]
J9A2	1X2HDR_SM	[58C2]
J9G1	XENONGAME_TH	[46B5]
L1B1	CMCHOKE_SM	[45C6]
L2G1	CMCHOKE_SM	[46B2]
L3A1	INDUCTOR_1210	[44C7]
L3A2	INDUCTOR_1210	[44C7]
L3A3	INDUCTOR_1210	[44D7]
L3A4	INDUCTOR_1210	[44B7]
L3F1	INDUCTOR_TH	[55C2]
L4G1	CMCHOKE_SM	[46C3]
L6C1	INDUCTOR_TH	[54D2]
L6F1	INDUCTOR_TH	[55C7]
L6G1	CMCHOKE_SM	[49C6]
L7C1	INDUCTOR_TH	[54B2]
L7F1	INDUCTOR_TH	[55D5]
L7G1	INDUCTOR_TH	[57D1]
L8B1	INDUCTOR_TH	[50B4]
L8E1	INDUCTOR_TH	[52B1]
L8F1	INDUCTOR_TH	[52A1]
L8F2	INDUCTOR_TH	[57C2]
L9B1	INDUCTOR_TH	[50B8]
L9C1	INDUCTOR_1210	[62B3]
L9D1	INDUCTOR_1210	[62C7]
L9D2	INDUCTOR_1210	[62C3]
L9G1	CMCHOKE_SM	[46C7]
L9V1	CMCHOKE_SM	[46A7]
LB7G1	LABEL_SM	[60D5]
MTG1B1	STD_MTG_HOLE_TH	[60C6]
MTG1G1	STD_MTG_HOLE_TH	[60C6]
MTG3C1	STD_MTG_HOLE_TH	[60B6]
MTG3E1	STD_MTG_HOLE_TH	[60B4]
MTG5B1	STD_MTG_HOLE_TH	[60C5]
MTG5C1	STD_MTG_HOLE_TH	[60A6]
MTG5E1	STD_MTG_HOLE_TH	[60A4]
MTG5G1	STD_MTG_HOLE_TH	[60C5]
MTG6C1	STD_MTG_HOLE_TH	[60A6]
MTG6E1	STD_MTG_HOLE_TH	[60B4]

MTG8C1	STD_MTG_HOLE_TH	[60B6]
MTG8E1	STD_MTG_HOLE_TH	[60A4]
MTG9B1	STD_MTG_HOLE_TH	[60C3]
MTG9G1	STD_MTG_HOLE_TH	[60C3]
Q1G2	PNP_SOT23	[47A3]
Q1G3	PNP_SOT23	[28A4]
Q1V1	PNP_SOT23	[47A4]
Q2F3	FET_VREG_DPAK	[55B3]
Q2N1	PNP_SOT23	[41A5]
Q2N3	PNP_SOT23	[44A4]
Q2P1	PNP_SOT23	[58A1]
Q3F1	FET_VREG_DPAK	[55C3]
Q3M1	PNP_DPAK	[43D3]
Q3M2	PNP_SOT23	[43D4]
Q6B1	FET_VREG_DPAK	[54D5]
Q6B2	FET_VREG_DPAK	[54C5]
Q6C1	FET_VREG_DPAK	[54C4]
Q6F1	FET_VREG_DPAK	[55C7]
Q6F2	FET_VREG_DPAK	[55B7]
Q7B1	FET_VREG_DPAK	[54C5]
Q7B2	FET_VREG_DPAK	[54B5]
Q7C1	FET_VREG_DPAK	[54B4]
Q7F1	FET_SOT23	[57C7]
Q7U1	PNP_SOT23	[57B7]
Q8B3	FET_SOT23	[53B1]
Q8B4	PNP_SOT23	[49A2]
Q8B5	PNP_SOT23	[49A3]
Q8B6	PNP_SOT23	[58B2]
Q8F1	FET_VREG_DPAK	[52A3]
Q8N1	PNP_2C_SOT223	[49B1]
Q9D3	FET_VREG_DPAK	[52B3]
Q9D4	FET_VREG_DPAK	[52C3]
Q9E1	FET_VREG_DPAK	[52C4]
Q9E3	FET_VREG_DPAK	[52B4]
Q9F1	FET_VREG_DPAK	[52A4]
Q9F2	FET_VREG_DPAK	[52A4]
Q9F4	FET_VREG_DPAK	[52A3]
R1A1	RESN_402	[39B2]
R1A2	RESN_402	[39B2]
R1A3	RESN_402	[39C2]
R1A4	RESN_402	[39D2]
R1A5	RESN_402	[45B5]
R1B1	RESN_603	[45C7]
R1B2	RESN_603	[45D7]
R1B3	RESN_402	[36B3]
R1B4	RESN_402	[39B3]
R1B5	RESN_402	[39B3]
R1B6	RESN_402	[39C4]
R1B7	RESN_402	[39D4]
R1B9	RESN_402	[36D7]
R1B10	RESN_402	[36C7]
R1B11	RESN_402	[39B7]
R1B12	RESN_402	[40B6]
R1B13	RESN_402	[39C3]
R1C1	RESN_402	[39C7]
R1C2	RESN_402	[33B7]
R1C3	RESN_402	[36C3]

R1C4	RESN_402	[33B8]
R1C5	RESN_402	[33B8]
R1C6	RESN_402	[33B7]
R1C7	RESN_402	[33B8]
R1C8	RESN_402	[36B6]
R1D2	RESN_402	[42B5]
R1D3	RESN_402	[42B5]
R1D4	RESN_402	[42B5]
R1D5	RESN_402	[47A6]
R1D6	RESN_402	[47B7]
R1E1	RESN_1210	[54A7]
R1E2	RESN_402	[42C5]
R1E3	RESN_1210	[54A7]
R1F7	RESN_402	[56D7]
R1F8	RESN_402	[56D7]
R1G1	RESN_1206	[47B3]
R1G2	RESN_402	[47B4]
R1G3	RESN_402	[43C6]
R1G4	RESN_402	[43C7]
R1M1	RESN_603	[39C2]
R1M2	RESN_603	[39B2]
R1M3	RESN_402	[45B5]
R1N1	RESN_402	[39B7]
R1N2	RESN_402	[39B7]
R1N3	RESN_402	[39B6]
R1N4	RESN_402	[39B6]
R1N5	RESN_402	[39B3]
R1N6	RESN_402	[39B4]
R1N7	RESN_402	[39B4]
R1N8	RESN_402	[40A3]
R1P1	RESN_402	[33B7]
R1P2	RESN_402	[33B8]
R1P3	RESN_402	[33B8]
R1P5	RESN_402	[33B7]
R1P6	RESN_402	[33B8]
R1P7	RESN_402	[35C6]
R1R1	RESN_402	[35D3]
R1R2	RESN_402	[47B7]
R1R3	RESN_402	[47B6]
R1R4	RESN_402	[48A3]
R1R5	RESN_402	[47B6]
R1U1	RESN_402	[56D5]
R1U2	RESN_402	[56D5]
R1U3	RESN_402	[34A4]
R1V1	RESN_402	[47A4]
R1V2	RESN_1206	[47B3]
R2A1	RESN_402	[44A2]
R2A2	RESN_402	[34B7]
R2A4	RESN_402	[44B5]
R2A5	RESN_402	[44B4]
R2A6	RESN_402	[44B5]
R2A7	RESN_402	[44B5]
R2A8	RESN_402	[44C5]
R2A9	RESN_402	[44B5]
R2A11	RESN_603	[29D7]
R2A12	RESN_603	[29C7]
R2A13	RESN_603	[29C7]

R2A14	RESN_603	[29B7]
R2B1	RESN_603	[41D6]
R2B2	RESN_402	[41B4]
R2B3	RESN_402	[41D4]
R2B4	RESN_402	[41B4]
R2B5	RESN_402	[41C4]
R2B6	RESN_603	[41D8]
R2B8	RESN_402	[33B6]
R2B9	RESN_402	[33B6]
R2B10	RESN_402	[33B7]
R2B11	RESN_402	[36C2]
R2B12	RESN_402	[36B3]
R2B13	RESN_402	[36C2]
R2B14	RESN_402	[36C3]
R2B15	RESN_402	[36B2]
R2B16	RESN_402	[34A7]
R2B19	RESN_402	[34A7]
R2C1	RESN_603	[38D7]
R2C3	RESN_402	[56A6]
R2D1	RESN_402	[42B6]
R2D2	RESN_402	[42C2]
R2D3	RESN_402	[42B6]
R2D4	RESN_402	[42B6]
R2D5	RESN_402	[42B6]
R2D6	RESN_402	[42C5]
R2D7	RESN_402	[42C6]
R2D8	RESN_402	[42B7]
R2D9	RESN_402	[13A7]
R2D10	RESN_402	[13A8]
R2D11	RESN_402	[12C1]
R2D12	RESN_402	[12C2]
R2E1	RESN_402	[13B4]
R2E2	RESN_402	[13B8]
R2E3	RESN_402	[13A7]
R2E4	RESN_402	[13B7]
R2E5	RESN_402	[12D2]
R2E6	RESN_1210	[54A7]
R2E7	RESN_1210	[54A7]
R2G2	RESN_402	[43B7]
R2G3	RESN_402	[43B6]
R2G5	RESN_603	[46A3]
R2M3	RESN_402	[34B7]
R2M4	RESN_402	[44A1]
R2M5	RESN_402	[34B7]
R2M6	RESN_402	[44A2]
R2M9	RESN_402	[44A3]
R2M10	RESN_402	[44A4]
R2N1	RESN_402	[41A2]
R2N2	RESN_402	[41A4]
R2N3	RESN_402	[41B7]
R2N4	RESN_402	[33B6]
R2N5	RESN_402	[33B6]
R2N6	RESN_402	[33B7]
R2N7	RESN_402	[43A2]
R2N8	RESN_402	[33C2]
R2N9	RESN_402	[34C3]
R2N10	RESN_402	[36B3]

R2N11	RESN_402	[36B3]
R2N12	RESN_402	[36B3]
R2N13	RESN_402	[58B6]
R2N14	RESN_402	[58C4]
R2N15	RESN_402	[34D7]
R2N19	RESN_402	[44A5]
R2N20	RESN_402	[44A1]
R2N21	RESN_402	[34D7]
R2N22	RESN_402	[41A5]
R2N23	RESN_402	[41A6]
R2P1	RESN_402	[27D4]
R2P2	RESN_402	[33C7]
R2P3	RESN_402	[27D4]
R2P4	RESN_402	[34C7]
R2P5	RESN_402	[33D7]
R2P6	RESN_402	[34C7]
R2P8	RESN_402	[33C6]
R2P9	RESN_402	[33D6]
R2P10	RESN_402	[34B2]
R2P11	RESN_402	[33C7]
R2P12	RESN_402	[34A2]
R2P13	RESN_402	[34A2]
R2P14	RESN_402	[35B6]
R2P15	RESN_402	[34B2]
R2P16	RESN_402	[33C7]
R2P17	RESN_603	[38C7]
R2P18	RESN_402	[58D4]
R2P19	RESN_402	[58A1]
R2R1	RESN_402	[23A7]
R2R2	RESN_402	[23A7]
R2R3	RESN_402	[24D7]
R2R4	RESN_402	[24D7]
R2R5	RESN_402	[12D2]
R2R6	RESN_402	[12A2]
R2T1	RESN_402	[12A1]
R2T2	RESN_402	[12B1]
R2T3	RESN_402	[25A7]
R2T4	RESN_402	[25A7]
R2T5	RESN_402	[26D7]
R2T6	RESN_402	[26D7]
R2T7	RESN_805	[54A2]
R2T8	RESN_805	[54A2]
R2V1	RESN_402	[43A2]
R3A2	RESN_402	[43B3]
R3A3	RESN_402	[44C7]
R3A4	RESN_402	[44D7]
R3A6	RESN_402	[44C7]
R3A7	RESN_402	[43C3]
R3A9	RESN_402	[44B7]
R3A10	RESN_603	[29B7]
R3A11	RESN_603	[29B7]
R3A12	RESN_603	[29A7]
R3A13	RESN_603	[29A7]
R3B1	RESN_402	[27C7]
R3B2	RESN_402	[27D8]
R3B3	RESN_402	[58B4]
R3B4	RESN_402	[27C2]

R3B5	RESN_402	[27C2]
R3B6	RESN_402	[27B2]
R3C7	RESN_402	[27C2]
R3C8	RESN_402	[27D2]
R3C9	RESN_402	[27C2]
R3C15	RESN_402	[27C2]
R3C16	RESN_402	[27D2]
R3C21	RESN_402	[56A5]
R3C22	RESN_402	[56A6]
R3C28	RESN_402	[13C8]
R3D1	RESN_402	[23A5]
R3D2	RESN_402	[24A7]
R3D3	RESN_402	[24A7]
R3D4	RESN_402	[23D7]
R3D5	RESN_402	[23D7]
R3E1	RESN_402	[25A5]
R3E2	RESN_402	[26A8]
R3E3	RESN_402	[26A7]
R3E4	RESN_402	[25D7]
R3E5	RESN_402	[25D7]
R3F1	RESN_402	[19A5]
R3G4	RESN_603	[46B3]
R3M1	RESN_402	[29B2]
R3M2	RESN_402	[44A6]
R3M3	RESN_402	[44A7]
R3M5	RESN_402	[29C4]
R3M6	RESN_402	[29C4]
R3M7	RESN_402	[29B2]
R3M8	RESN_402	[43C4]
R3M9	RESN_402	[43D4]
R3N6	RESN_402	[49B8]
R3N7	RESN_402	[49B7]
R3N8	RESN_402	[58A2]
R3P6	RESN_402	[34B1]
R3P7	RESN_402	[34C2]
R3R1	RESN_402	[24A5]
R3T1	RESN_402	[26A5]
R3T2	RESN_402	[15B4]
R3U1	RESN_402	[20A5]
R3V1	RESN_402	[55C3]
R3V3	RESN_402	[55A4]
R3V4	RESN_402	[55A7]
R3V5	RESN_402	[55A7]
R4B1	RESN_402	[27D7]
R4B2	RESN_402	[27D5]
R4B3	RESN_402	[28A2]
R4B4	RESN_402	[27A3]
R4B5	RESN_402	[27A2]
R4B6	RESN_402	[27B2]
R4B8	RESN_402	[27D6]
R4B9	RESN_402	[27D7]
R4B10	RESN_402	[28D2]
R4B11	RESN_402	[28D1]
R4B12	RESN_402	[28C6]
R4B13	RESN_402	[28D2]
R4B14	RESN_402	[28D1]
R4B15	RESN_402	[28B7]

R4B17	RESN_402	[27C7]
R4B18	RESN_402	[28C7]
R4B19	RESN_603	[28C1]
R4B20	RESN_603	[28B1]
R4B21	RESN_603	[28B1]
R4B22	RESN_603	[28C1]
R4B23	RESN_402	[28C2]
R4B24	RESN_402	[27A3]
R4B25	RESN_402	[27B2]
R4B26	RESN_402	[27C2]
R4B27	RESN_402	[27C2]
R4C1	RESN_402	[28B7]
R4C2	RESN_402	[28B6]
R4C3	RESN_402	[13A6]
R4C4	RESN_402	[13A5]
R4C5	RESN_402	[13A5]
R4C6	RESN_402	[13A3]
R4C7	RESN_402	[13A6]
R4C8	RESN_402	[27C2]
R4C9	RESN_402	[27D2]
R4C10	RESN_402	[27D2]
R4C11	RESN_402	[27D2]
R4C12	RESN_402	[27D2]
R4C13	RESN_402	[27B2]
R4C14	RESN_402	[27B2]
R4C15	RESN_402	[27B3]
R4C16	RESN_402	[27B3]
R4C31	RESN_603	[56C4]
R4D1	RESN_402	[13C4]
R4D2	RESN_402	[13C4]
R4F1	RESN_402	[20A7]
R4F2	RESN_402	[20A8]
R4F3	RESN_402	[19D7]
R4F4	RESN_402	[19D7]
R4F5	RESN_402	[21A5]
R4F6	RESN_402	[13B3]
R4F7	RESN_402	[12B1]
R4F8	RESN_402	[12C1]
R4G1	RESN_402	[55B1]
R4G4	RESN_603	[46C3]
R4G5	RESN_603	[46D3]
R4G6	RESN_402	[55B1]
R4G7	RESN_402	[55A1]
R4G8	RESN_402	[55A1]
R4G9	RESN_402	[55C1]
R4N1	RESN_402	[30C7]
R4N2	RESN_402	[28C7]
R4N3	RESN_402	[28C7]
R4N4	RESN_402	[27B4]
R4N5	RESN_402	[27C7]
R4N6	RESN_402	[27C7]
R4P1	RESN_402	[27C7]
R4P2	RESN_402	[43C4]
R4P13	RESN_603	[56C4]
R4P14	RESN_603	[56C3]
R4R1	RESN_402	[15A7]
R4R2	RESN_402	[15A7]

R4R3	RESN_402	[13C8]
R4R4	RESN_402	[15B8]
R4R5	RESN_402	[15A8]
R4R6	RESN_402	[15A3]
R4R7	RESN_402	[15A3]
R4R8	RESN_402	[13B7]
R4R9	RESN_402	[12B8]
R4T1	RESN_402	[13B8]
R4T2	RESN_402	[15A4]
R4T3	RESN_402	[14A8]
R4T4	RESN_402	[14B8]
R4T5	RESN_402	[14A3]
R4T6	RESN_402	[14A7]
R4T7	RESN_402	[14A7]
R4T8	RESN_402	[14A3]
R4U1	RESN_402	[22A5]
R4U2	RESN_402	[20D7]
R4U3	RESN_402	[20D7]
R4U4	RESN_402	[19A7]
R4U5	RESN_402	[19A7]
R4U6	RESN_402	[12A1]
R4V1	RESN_402	[55B3]
R4V2	RESN_402	[55B5]
R4V3	RESN_402	[55B5]
R4V4	RESN_402	[55B6]
R4V5	RESN_402	[55A8]
R4V6	RESN_402	[55B8]
R4V7	RESN_402	[55C6]
R4V9	RESN_402	[55B8]
R4V10	RESN_402	[55A6]
R4V11	RESN_402	[55C8]
R5B1	RESN_402	[56B6]
R5B2	RESN_402	[56A6]
R5B3	RESN_1206	[56B7]
R5C4	RESN_805	[56A4]
R5C5	RESN_402	[13A6]
R5C6	RESN_805	[56B4]
R5C8	RESN_402	[13A6]
R5C9	RESN_402	[56B1]
R5C10	RESN_402	[13A6]
R5C11	RESN_402	[12D8]
R5C12	RESN_402	[12D8]
R5D1	RESN_402	[13D8]
R5D2	RESN_402	[13D7]
R5E1	RESN_402	[14A4]
R5E2	RESN_402	[14B4]
R5F1	RESN_402	[22A7]
R5F2	RESN_402	[22A7]
R5F3	RESN_402	[21D7]
R5F4	RESN_402	[21D7]
R5N1	RESN_402	[53B2]
R5P1	RESN_402	[56B2]
R5P2	RESN_402	[56B2]
R5P3	RESN_402	[13A6]
R5R1	RESN_402	[12D8]
R5R2	RESN_402	[12C8]
R5R3	RESN_402	[12A8]

R5U1	RESN_402	[22D7]
R5U2	RESN_402	[22D7]
R5U3	RESN_402	[21A7]
R5U4	RESN_402	[21A7]
R5V2	RESN_402	[43D6]
R5V3	RESN_402	[43D7]
R6C1	RESN_805	[56B3]
R6C2	RESN_805	[54D3]
R6D4	RESN_402	[4D5]
R6D5	RESN_402	[4D5]
R6E1	RESN_402	[4B2]
R6E2	RESN_402	[4A5]
R6G7	RESN_603	[49C7]
R6G8	RESN_603	[49C7]
R6R1	RESN_402	[56A1]
R6R2	RESN_402	[56A2]
R6R3	RESN_402	[56A2]
R6R4	RESN_402	[4D7]
R6R5	RESN_402	[4C7]
R6R6	RESN_402	[4C8]
R6R7	RESN_402	[4C8]
R6R8	RESN_402	[4C8]
R6R9	RESN_402	[4C8]
R6T1	RESN_402	[56C5]
R6T3	RESN_402	[56B6]
R6T4	RESN_402	[56C5]
R7B2	RESN_402	[49B2]
R7B6	RESN_805	[54B3]
R7D1	RESN_402	[4C7]
R7D2	RESN_402	[4C7]
R7E1	RESN_402	[50D6]
R7E2	RESN_402	[50D6]
R7E3	RESN_402	[50A6]
R7E4	RESN_402	[50D6]
R7E5	RESN_402	[50D6]
R7E6	RESN_402	[50C6]
R7E7	RESN_402	[4A5]
R7E8	RESN_402	[4A4]
R7F1	RESN_402	[4A4]
R7F2	RESN_402	[4A5]
R7F3	RESN_402	[4A2]
R7F4	RESN_402	[4A2]
R7F7	RESN_402	[4A2]
R7F9	RESN_402	[57C8]
R7G23	RESN_805	[57D1]
R7N1	RESN_805	[49A1]
R7N2	RESN_805	[49A1]
R7N3	RESN_805	[49A2]
R7N4	RESN_805	[49A1]
R7R1	RESN_402	[4B6]
R7R2	RESN_402	[4B6]
R7R3	RESN_402	[4A7]
R7R4	RESN_402	[4D7]
R7R5	RESN_402	[4A8]
R7R8	RESN_402	[4B7]
R7R9	RESN_402	[4B1]
R7R10	RESN_402	[4D7]

R7R11	RESN_402	[4D7]
R7R12	RESN_402	[4A8]
R7R13	RESN_402	[4A7]
R7R14	RESN_402	[4B5]
R7R15	RESN_402	[4B7]
R7R16	RESN_402	[4D7]
R7R17	RESN_402	[4C8]
R7R18	RESN_402	[4A7]
R7R19	RESN_402	[4A7]
R7R20	RESN_402	[4A8]
R7R21	RESN_402	[4A8]
R7R22	RESN_402	[4A7]
R7R23	RESN_402	[4A7]
R7T2	RESN_402	[6C5]
R7T4	RESN_402	[50D5]
R7T5	RESN_402	[50D4]
R7T6	RESN_402	[50D5]
R7T7	RESN_402	[50D4]
R7T8	RESN_402	[50D5]
R7T9	RESN_402	[50D4]
R7T10	RESN_402	[56D4]
R7T11	RESN_402	[50C5]
R7T12	RESN_402	[50C4]
R7T13	RESN_402	[50C5]
R7T14	RESN_402	[50C4]
R7T15	RESN_402	[50C5]
R7T16	RESN_402	[50C4]
R7T18	RESN_402	[4B6]
R7T19	RESN_402	[57C7]
R7U3	RESN_402	[4A5]
R7U4	RESN_402	[57B8]
R7U5	RESN_402	[57B7]
R7U6	RESN_402	[57B5]
R7U7	RESN_402	[57B3]
R7U8	RESN_402	[57A6]
R7V4	RESN_402	[34C2]
R8A1	RESN_402	[49C4]
R8A2	RESN_402	[49C3]
R8A3	RESN_402	[49A3]
R8A4	RESN_402	[49A3]
R8A5	RESN_402	[58B3]
R8B1	RESN_402	[53D3]
R8B2	RESN_402	[53A7]
R8B3	RESN_603	[53A6]
R8B4	RESN_603	[53C3]
R8B5	RESN_402	[49B3]
R8B6	RESN_402	[58B2]
R8B7	RESN_402	[53D3]
R8B8	RESN_402	[53D3]
R8B9	RESN_402	[53C3]
R8B10	RESN_402	[53C3]
R8C1	RESN_402	[53B2]
R8C2	RESN_402	[58A5]
R8C3	RESN_402	[58A4]
R8C4	RESN_402	[58A4]
R8C5	RESN_402	[58A4]
R8C6	RESN_402	[58A4]

R8C7	RESN_603	[53B6]
R8C8	RESN_402	[58A2]
R8C9	RESN_402	[53D7]
R8F7	RESN_402	[51C7]
R8F8	RESN_402	[51C2]
R8G1	RESN_603	[51D6]
R8G3	RESN_402	[51A6]
R8N1	RESN_402	[49B2]
R8N2	RESN_805	[53C2]
R8N3	RESN_805	[53A3]
R8N4	RESN_805	[53A2]
R8N5	RESN_805	[53A3]
R8N6	RESN_805	[53A2]
R8N7	RESN_805	[53D6]
R8N17	RESN_402	[34D2]
R8N18	RESN_402	[34C2]
R8P1	RESN_603	[53C7]
R8P3	RESN_402	[53C7]
R8P4	RESN_402	[53C7]
R8P5	RESN_603	[53B7]
R8P6	RESN_603	[53B7]
R8P7	RESN_402	[53C8]
R8P8	RESN_402	[58A2]
R8P9	RESN_402	[53D7]
R8U1	RESN_603	[51B2]
R8U2	RESN_402	[51B3]
R8U3	RESN_402	[51C5]
R8U4	RESN_402	[51B2]
R8U5	RESN_402	[51D5]
R8U6	RESN_402	[57B4]
R8U7	RESN_402	[57C5]
R8U8	RESN_402	[57C6]
R8U9	RESN_402	[57C6]
R8U10	RESN_603	[51A7]
R8U11	RESN_402	[51A5]
R8U12	RESN_402	[57A5]
R8U13	RESN_402	[51A7]
R8U14	RESN_402	[57B2]
R8V2	RESN_603	[51B7]
R8V3	RESN_603	[51B6]
R8V4	RESN_603	[51B7]
R8V5	RESN_603	[51B6]
R8V7	RESN_603	[51C6]
R8V9	RESN_603	[51C6]
R8V10	RESN_805	[51D6]
R9B1	RESN_402	[53B2]
R9C2	RESN_402	[62B6]
R9C3	RESN_402	[62B4]
R9C5	RESN_805	[62B2]
R9C6	RESN_402	[62B6]
R9C7	RESN_402	[62B3]
R9D1	RESN_402	[62C6]
R9D2	RESN_402	[62C4]
R9D3	RESN_402	[62C3]
R9D4	RESN_805	[62C2]
R9D5	RESN_402	[62C6]
R9E1	RESN_805	[52B2]

R9F1	RESN_805	[52A2]
R9G1	RESN_603	[46B7]
R9G2	RESN_603	[46C7]
R9T1	RESN_805	[52C5]
R9T2	RESN_805	[52C7]
R9U1	RESN_805	[52A5]
R9U2	RESN_805	[52B7]
R9V1	RESN_603	[46A7]
R9V2	RESN_603	[46A7]
RT1B1	THERMISTOR_1206	[45D5]
RT1R1	THERMISTOR_1206	[48B3]
RT1U1	THERMISTOR_1812	[48B4]
RT2G1	THERMISTOR_1206	[46D3]
RT2M1	THERMISTOR_1206	[44D4]
RT7C1	THERMISTOR_603	[53D8]
RT8F1	THERMISTOR_603	[51C6]
RT8G1	THERMISTOR_1206	[46D7]
RT8G2	THERMISTOR_1206	[46B7]
ST1P1	SHORT_SM	[38B7]
ST1P2	SHORT_SM	[38B7]
ST1P3	SHORT_SM	[38A7]
ST2F1	SHORT_SM	[55C1]
ST2F2	SHORT_SM	[55C3]
ST2P1	SHORT_SM	[38C7]
ST2P2	SHORT_SM	[37B7]
ST2P3	SHORT_SM	[37C7]
ST2P4	SHORT_SM	[37A7]
ST3G1	SHORT_SM	[55C3]
ST4C1	SHORT_SM	[28A7]
ST4C2	SHORT_SM	[28A7]
ST4C3	SHORT_SM	[28A7]
ST4C4	SHORT_SM	[28A7]
ST4C5	SHORT_SM	[28A7]
ST5R1	SHORT_SM	[53B7]
ST5R2	SHORT_SM	[53D7]
ST5V1	SHORT_SM	[55C7]
ST6D1	SHORT_SM	[6C7]
ST6F1	SHORT_SM	[55C8]
ST6F2	SHORT_SM	[55C7]
ST6R1	SHORT_SM	[6B7]
ST6R2	SHORT_SM	[6A7]
ST7D1	SHORT_SM	[6A7]
ST7D2	SHORT_SM	[57B2]
ST7R1	SHORT_SM	[6C7]
ST7T1	SHORT_SM	[51B4]
ST7T2	SHORT_SM	[51A8]
ST8C1	SHORT_SM	[53A8]
ST8F1	SHORT_SM	[51A7]
TP5A1	TDRX4_TH	[61C1]
TP5A2	TDRX4_TH	[61B1]
TP6A1	TDRX2_TH	[61C1]
TP6A2	TDRX2_TH	[61D1]
TP6D1	PROBE_SMT	[4C7]
TP7A1	TDRX4_TH	[61B7]
TP7A2	TDRX4_TH	[61A7]
TP7M1	TDRX2_TH	[61C7]
TP7M2	TDRX2_TH	[61D7]

TP7R1	PROBE_SMT	[4D2]
TP7R2	PROBE_SMT	[4C2]
TP7R3	PROBE_SMT	[4C2]
TP7R4	PROBE_SMT	[4C2]
TP8A1	TDRX2_TH	[61B7]
TP8A2	TDRX2_TH	[61C7]
TP8M1	TDRX4_TH	[61A7]
TP8M2	TDRX4_TH	[61A7]
U1B1	BCM5241_LCC32	[40B4]
U1B2	ICS1893BF_SSOP	[39C5]
U1F1	NCP5662_DPAK	[56D6]
U1F2	NCP1117_DPAK	[46A3]
U1G1	IR_WHOLDER_TH	[43A4]
U1R1	SI4501DY_SO8	[47B4]
U1U1	SN74LVC1G14_SC70	[34A5]
U2B1	XDAC_SOIC14	[41C6]
U2C1	SB_BGA	[33C4]
U2C1	SB_BGA	[34C4]
U2C1	SB_BGA	[35C5]
U2C1	SB_BGA	[36C5]
U2C1	SB_BGA	[37C4]
U2C1	SB_BGA	[38B5]
U2D1	SN74LVC1G125_SC70	[12B2]
U2E1	NAND_TSOP	[42B3]
U2E2	SN74LVC1G125_SC70	[12D2]
U2R1	SN74LVC1G125_SC70	[12A2]
U2T1	NCP1117_DPAK	[54A5]
U3D1	GDDR136_BGA136	[23C6 23C2]
U3E1	GDDR136_BGA136	[25C6 25C2]
U3P1	NCP1117_SOT223	[56A7]
U3R1	GDDR136_BGA136	[24C2 24C6]
U3T1	GDDR136_BGA136	[26C6 26C2]
U4C1	AT25020A_SOI8	[13A4]
U4C2	HANA_BGA225	[27C5]
U4C2	HANA_BGA225	[28C4]
U4C2	HANA_BGA225	[30C5]
U4C2	HANA_BGA225	[31B5]
U4D1	NBY2_BGA	[12C6]
U4D1	NBY2_BGA	[13C5]
U4D1	NBY2_BGA	[14C3 14C7]
U4D1	NBY2_BGA	[15C7 15C3]
U4D1	NBY2_BGA	[16C3]
U4D1	NBY2_BGA	[17B3 17B5 17B7 17B2]
U4D1	NBY2_BGA	[59C8]
U4F1	GDDR136_BGA136	[19C6 19C2]
U4U1	GDDR136_BGA136	[20C2 20C6]
U4V1	ADP1823_LCC32	[55C5]
U5B1	NCP1117_DPAK	[56C7]
U5B2	NCP1117_DPAK	[56B7]
U5C1	NCP1117_SOT223	[56C3]
U5F1	GDDR136_BGA136	[21B6 21C2]
U5U1	GDDR136_BGA136	[22B6 22C2]
U6R1	NCP1117_SOT223	[56A3]
U6T1	NCP502D_SC70	[56D2]
U6T2	LP2980_SOT23_5	[56D2]
U7D1	LOKI_BGA	[4C4]

U7D1	LOKI_BGA	[5C5]
U7D1	LOKI_BGA	[6C3]
U7D1	LOKI_BGA	[7C7 7C5 7C2]
U7D1	LOKI_BGA	[8B4 8B2 8B7]
U7D1	LOKI_BGA	[59B3]
U7E1	AT25020A_SOI8	[4A3]
U7F1	FET_VREG_DUAL_1_SO	[57C3]
	-8	
U7U2	IR3638_SSOP	[57C4]
U8N1	NCP5331_LQFP32	[53C5]
U8U1	ADP3190A_TSSOP28	[51C4]
U9C1	SIMPLESWR_SOT23	[62B5]
U9D1	SIMPLESWR_SOT23	[62C5]
U9T1	MOSDRIVER_SOI8	[52B6]
U9U1	MOSDRIVER_SOI8	[52A6]
Y3B1	CRYSTAL_SM	[27D8]